

# DRONE TECHNICIAN

NSQF LEVEL - 3

---

**TRADE THEORY**

---

**SECTOR: AEROSPACE & AVIATION**

**(As per revised syllabus July 2022 - 1200 Hrs)**



Directorate General of Training

**DIRECTORATE GENERAL OF TRAINING  
MINISTRY OF SKILL DEVELOPMENT & ENTREPRENEURSHIP  
GOVERNMENT OF INDIA**



**NATIONAL INSTRUCTIONAL  
MEDIA INSTITUTE, CHENNAI**

---

Post Box No. 3142, CTI Campus, Guindy, Chennai - 600 032

**Sector : Aerospace & Aviation**

**Duration : Six Months**

**Trade : Drone Technician - Trade Theory - NSQF Level - 3 (Revised 2022)**

**Developed & Published by**



**National Instructional Media Institute**

Post Box No.3142

Guindy, chennai-600 032

INDIA

Email: [chennai-nimi@nic.in](mailto:chennai-nimi@nic.in)

Website: [www.nimi.gov.in](http://www.nimi.gov.in)

**Copyright © 2023 National Instructional Media Institute, Chennai**

First Edition : January 2023

Copies : 500

**Rs.150/-**

All rights reserved.

No part of this publication can be reproduced or transmitted in any form or by any means, electronic or mechanical, including photocopy, recording or any information storage and retrieval system, without permission in writing from the National Instructional Media Institute, Chennai.

## FOREWORD

The Government of India has set an ambitious target of imparting skills to 30 crores people, one out of every four Indians to help them secure jobs as part of the National Skills Development Policy. Industrial Training Institutes (ITIs) play a vital role in this process especially in terms of providing skilled manpower. Keeping this in mind, and for providing the current industry relevant skill training to Trainees, ITI syllabus has been recently updated with the help of Mentor Councils comprising various stakeholder's viz. Industries, Entrepreneurs, Academicians and representatives from ITIs.

The National Instructional Media Institute (NIMI), Chennai, an autonomous body under the Directorate General of Training (DGT), Ministry of Skill Development & Entrepreneurship is entrusted with developing producing and disseminating Instructional Media Packages (IMPs) required for ITIs and other related institutions.

The institute has now come up with instructional material to suit the revised curriculum for **Drone Technician - Trade Theory NSQF Level - 3 (Revised 2022)** in **Aerospace & Aviation** Sector under **Six Months Pattern**. The NSQF Level - 3 (Revised 2022) Trade Theory will help the trainees to get an international equivalency standard where their skill proficiency and competency will be duly recognized across the globe and this will also increase the scope of recognition of prior learning. NSQF Level - 3 (Revised 2022) trainees will also get the opportunities to promote life long learning and skill development. I have no doubt that with NSQF Level - 3 (Revised 2022) the trainers and trainees of ITIs, and all stakeholders will derive maximum benefits from these IMPs and that NIMI's effort will go a long way in improving the quality of Vocational training in the country.

The Executive Director & Staff of NIMI and members of Media Development Committee deserve appreciation for their contribution in bringing out this publication.

Jai Hind

Addl. Secretary/Director General (Training)  
Ministry of Skill Development & Entrepreneurship,  
Government of India.

New Delhi - 110 001

## PREFACE

The National Instructional Media Institute (NIMI) was established in 1986 at Chennai by then Directorate General of Employment and Training (D.G.E & T), Ministry of Labour and Employment, (now under Directorate General of Training, Ministry of Skill Development and Entrepreneurship) Government of India, with technical assistance from the Govt. of Federal Republic of Germany. The prime objective of this Institute is to develop and provide instructional materials for various trades as per the prescribed syllabus under the Craftsman and Apprenticeship Training Schemes.

The instructional materials are created keeping in mind, the main objective of Vocational Training under NCVT/NAC in India, which is to help an individual to master skills to do a job. The instructional materials are generated in the form of Instructional Media Packages (IMPs). An IMP consists of Theory book, Practical book, Test and Assignment book, Instructor Guide, Audio Visual Aid (Wall charts and Transparencies) and other support materials.

The trade practical book consists of series of exercises to be completed by the trainees in the workshop. These exercises are designed to ensure that all the skills in the prescribed syllabus are covered. The trade theory book provides related theoretical knowledge required to enable the trainee to do a job. The test and assignments will enable the instructor to give assignments for the evaluation of the performance of a trainee. The wall charts and transparencies are unique, as they not only help the instructor to effectively present a topic but also help him to assess the trainee's understanding. The instructor guide enables the instructor to plan his schedule of instruction, plan the raw material requirements, day to day lessons and demonstrations.

IMPs also deals with the complex skills required to be developed for effective team work. Necessary care has also been taken to include important skill areas of allied trades as prescribed in the syllabus.

The availability of a complete Instructional Media Package in an institute helps both the trainer and management to impart effective training.

The IMPs are the outcome of collective efforts of the staff members of NIMI and the members of the Media Development Committees specially drawn from Public and Private sector industries, various training institutes under the Directorate General of Training (DGT), Government and Private ITIs.

NIMI would like to take this opportunity to convey sincere thanks to the Directors of Employment & Training of various State Governments, Training Departments of Industries both in the Public and Private sectors, Officers of DGT and DGT field institutes, proof readers, individual media developers and coordinators, but for whose active support NIMI would not have been able to bring out this materials.

**Chennai - 600 032**

**EXECUTIVE DIRECTOR**

## ACKNOWLEDGEMENT

National Instructional Media Institute (NIMI) sincerely acknowledges with thanks for the co-operation and contribution extended by the following Media Developers and their sponsoring organisation to bring out this IMP **(Trade Theory)** for the trade of **Drone Technician - NSQF Level - 3 (Revised 2022)** under the **Aerospace & Aviation** Sector for ITIs.

### MEDIA DEVELOPMENT COMMITTEE MEMBERS

Shri. Kamil Naqvi - CEO, Hayedrone Flying Academy Pvt Ltd.  
Amroha, Uttar Pradesh.

### NIMI - COORDINATORS

Shri. Nirmalya Nath - Deputy Director,  
NIMI, Chennai - 32.

Shri. S. Gopalakrishnan - Assistant Manager  
NIMI, Chennai - 32.

NIMI records its appreciation of the Data Entry, CAD, DTP Operators for their excellent and devoted services in the process of development of this Instructional Material.

NIMI also acknowledges with thanks, the invaluable efforts rendered by all other staff who have contributed for the development of this Instructional Material.

NIMI is grateful to all others who have directly or indirectly helped in developing this IMP.

# INTRODUCTION

## TRADE PRACTICAL

The trade practical manual is intended to be used in practical workshop. It consists of a series of practical exercises to be completed by the trainees during the course of the **Drone Technician** trade supplemented and supported by instructions/ informations to assist in performing the exercises. These exercises are designed to ensure that all the skills in compliance with NSQF Level - 3 (Revised 2022) syllabus are covered. The manual is divided into Twelve modules.

- Module 1 - Safety Rules and Regulations
- Module 2 - Identify & Select Different Types of Drones
- Module 3 - Identify & Test Various Electronic SMD Components
- Module 4 - Measure Different Type Electrical Parameters and Record The Data Related with Drone Hardware
- Module 5 - Identification of Different Type of Batteries, Battery Specifications and Their Charging Techniques Used In Drone
- Module 6 - Identify & Select Different Types of Drones, Drone Rules and Regulations, Drone Applications, and Important Safety Precautions
- Module 7 - Identify, Select and Test Hardware Assembly, Driver For BLDC Motors
- Module 8 - Inspect, Test and Execute GPS Navigation and Telemetry Module, Different RF Blocks and Antennas Used In RF Transmitter and Receiver
- Module 9 - Test and Troubleshoot Flight Controller Board (FCB), Electronic Speed Controller (ESC) and Its Associated Peripherals
- Module 10 - Calibrate and Troubleshoot Drone Gimbal and Drone Payload
- Module 11 - Identify and Resolve Common Error Messages and Corrections By Software Debugging
- Module 12 - Inspect, Test and Execute Primary and Secondary Servicing with Troubleshoot Malfunctioning, and Repair Issues Discovered

The skill training in the shop floor is planned through a series of practical exercises centred around some practical project. However, there are few instances where the individual exercise does not form a part of project.

While developing the practical manual a sincere effort was made to prepare each exercise which will be easy to understand and carry out even by below average trainee. However the development team accept that there is a scope for further improvement. NIMI, looks forward to the suggestions from the experienced training faculty for improving the manual.

## TRADE THEORY

The manual of trade theory consists of theoretical information for the Course of the **Drone Technician** Trade Theory NSQF Level - 3 (Revised 2022) in **Aerospace & Aviation**. The contents are sequenced according to the practical exercise contained in NSQF Level - 3 (Revised 2022) syllabus on Trade Theory attempt has been made to relate the theoretical aspects with the skill covered in each exercise to the extent possible. This correlation is maintained to help the trainees to develop the perceptual capabilities for performing the skills.

The trade theory has to be taught and learnt along with the corresponding exercise contained in the manual on trade practical. The indicating about the corresponding practical exercise are given in every sheet of this manual.

It will be preferable to teach/learn the trade theory connected to each exercise atleast one class before performing the related skills in the shop floor. The trade theory is to be treated as an integrated part of each exercise.

The material is not the purpose of self learning and should be considered as supplementary to class room instruction.

## CONTENTS

Lesson No.	Title of the Lesson	Learning Outcome	Page No.
	<b>Module 1: Safety Rules and Regulations</b>		
1.1.01	Familiar with industrial training institute		1
1.1.02	Importance of safety and general precautions observed in the industry/shop floor		3
1.1.03	First-aid	1	9
1.1.04	Guidelines for good shop floor maintenance		14
1.1.05	Occupational health and safety		17
1.1.06	Safety Sign		19
1.1.07-10	Different types of RPAS.		24
	<b>Module 2: Identify &amp; Select Different Types of Drones</b>		
1.2.11-20	Drones based on aerial platforms and construction materials.	2	30
	<b>Module 3: Identify &amp; Test Various Electronic SMD Components</b>		
1.3.21-26	Illustrate soldering and its componets.	3	36
	<b>Module 4: Measure Different Type Electrical Parameters and Record The Data Related with Drone Hardware</b>		
1.4.27-34	Introduction of electrical components and its parameters.	4	45
	<b>Module 5: Identification of Different Type of Batteries, Battery Specifications and Their Charging Techniques Used In Drone</b>		
1.5.35-42	Introduction of different types of drone batteries and its specifications.	5	51
	<b>Module 6: Identify &amp; Select Different Types of Drones, Drone Rules and Regulations, Drone Applications, and Important Safety Precautions</b>		
1.6.43-52	Explore of different sensors used in drone and their roles and characteristics.	6	57
	<b>Module 7: Identify, Select and Test Hardware Assembly, Driver For BLDC Motors</b>		
1.7.53-60	Explore diff erent motors and its functioning	7	66
	<b>Module 8: Inspect, Test and Execute GPS Navigation and Telemetry Module, Different RF Blocks and Antennas Used In RF Transmitter and Receiver</b>		
1.8.61-69	Different types of antennas used for drones	8	72
	<b>Module 9: Test and Troubleshoot Flight Controller Board (FCB),Electronic Speed Controller (ESC) and Its Associated Peripherals</b>		
1.9.70-82	Illustrate flight controller board and Electronic Speed Controller	9	79
	<b>Module 10: Calibrate and Troubleshoot Drone Gimbal and Drone Payload</b>		
1.10.83-90	Various applications of drones in different field.	10	83

Lesson No.	Title of the Lesson	Learning Outcome	Page No.
1.11.91-101	<b>Module 11: Identify and Resolve Common Error Messages and Corrections By Software Debugging</b> Understand software, its debugging and python programming	11	86
1.12.102-112	<b>Module 12: Inspect, Test and Execute Primary and Secondary Servicing with Troubleshoot Malfunctioning, and Repair Issues Discovered</b> Drone service, Visual inspection and gimbal handling.	12	91

## LEARNING / ASSESSABLE OUTCOME

On completion of this book you shall be able to

S.No.	Learning Outcome	Ref. Ex.No.
1	<b>Identify &amp; select different types of drones, drone rules and regulations, drone applications, and important safety precautions. (Mapped NOS: ELE/N7308)</b>	1.1.01 - 1.1.10
2	<b>Identify &amp; select different drone's mechanical parts, aerodynamics of wings, propellers and disassembly and reassembly of common drone platform with flying practices. (Mapped NOS: ELE/N7308)</b>	1.2.11 - 1.2.20
3	<b>Identify and test various electronic SMD components using proper measuring instruments and Identify, place, solder and de-solder and different SMD discrete components and ICs package with due care and following safety norms using proper tools/setup. (Mapped NOS: ELE/N7308)</b>	1.3.21 - 1.3.26
4	<b>Measure different type electrical parameters and record the data related with drone hardware. (Mapped NOS: ELE/N7005)</b>	1.4.27 - 1.4.34
5	<b>Identification of different type of batteries, battery specifications and their charging techniques used in drone. (Mapped NOS: ELE/N9401)</b>	1.5.35 - 1.5.42
6	<b>Test different sensors, their characteristics and repair which are commonly used in different drones. (Mapped NOS: ELE/N7308)</b>	1.6.43 - 1.6.52
7	<b>Identify, select and test hardware assembly, driver for BLDC motors. (Mapped NOS: ELE/N9402)</b>	1.7.53 - 1.7.60
8	<b>Inspect, test and execute GPS navigation and telemetry module, different RF blocks and antennas used in RF transmitter and receiver. (Mapped NOS: ELE/N7308)</b>	1.8.61 - 1.8.69
9	<b>Test and troubleshoot Flight Controller Board (FCB), Electronic Speed Controller (ESC) and its associated peripherals. (Mapped NOS: ELE/N9403)</b>	1.9.70 - 1.9.82
10	<b>Calibrate and troubleshoot drone gimbal and drone payload. (Mapped NOS: ELE/N9404)</b>	1.10.83-1.10.90
11	<b>Identify and resolve common error messages and corrections by software debugging. (Mapped NOS: ELE/N9405)</b>	1.11.91- 1.11.101
12	<b>Inspect, test and execute primary and secondary servicing with trouble shoot malfunctioning, and repair issues discovered. (Mapped NOS: ELE/N7005)</b>	1.12.102-1.12.112



## SYLLABUS

Duration	Reference Learning outcome	Professional Skills (Trade Practical) With Indicative Hours	Professional Knowledge (Trade Theory)
Professional Skill 42 Hrs; Professional Knowledge 12 Hrs	Identify & select different types of drones, drone rules and regulations, drone applications, and important safety precautions. (Mapped NOS: ELE/N7308)	<ol style="list-style-type: none"> <li>1 Visit to various sections of the institute and identify location of various installations.</li> <li>2 Identify safety signs for danger, warning, caution &amp; personal safety message.</li> <li>3 Practice Use of Personal Protective Equipment (PPE).</li> <li>4 Practice elementary first aid.</li> <li>5 Practice Preventive measures for electrical accidents &amp; steps to be taken in such accidents.</li> <li>6 Practice Use of Fire Extinguishers.</li> </ol>	<p>Familiarization with the working of Industrial Training Institute system.</p> <p>Importance of safety and precautions to be taken in the industry/ shop floor.</p> <p>Introduction to PPEs. Introduction to First Aid. Importance of housekeeping &amp; good shop floor practices.</p>
Professional Skill 63 Hrs; Professional Knowledge 18 Hrs	Identify & select different drone's mechanical parts, aerodynamics of wings, propellers and disassembly and reassembly of common drone platform with flying practices. (Mapped NOS: ELE/N7308)	<ol style="list-style-type: none"> <li>7 Identify Different types of Drones.</li> <li>8 Select basic components.</li> <li>9 Apply principles of flight to Drones.</li> <li>10 Identify &amp; prepare specific Flight Planning Procedures for specific drone flights.</li> </ol> <ol style="list-style-type: none"> <li>11 Identify &amp; select different building blocks of the drone.</li> <li>12 Test drone's different block functionality &amp; their interconnectivity.</li> <li>13 Identify various types of body material used in drone.</li> <li>14 Recognize basic principles of flying like Bernoulli's principle.</li> <li>15 Identify multi rotor design, various configurations, airframe sizes and their construction.</li> <li>16 Identify different propeller designs and design using 3D printer.</li> <li>17 Design and development of Drone's body component using 3D printer and related software</li> <li>18 Identify type of motor used in drone.</li> <li>19 Identify &amp; prepare specific flight planning procedures to drone flights.</li> <li>20 Practice drone flying to check to identify faults in drone.</li> </ol>	<p>Different types of Drones, Nomenclatures, History of aerial drones, reputation, airframe, configurations, basic components, current/future uses of drones.</p> <p>Occupational Safety &amp; Health: Health, Safety and Environment guidelines, legislations &amp; regulations as applicable.</p> <p>Understanding Aerial platforms. Types of drones based on aerial platforms. Types of drones based on body material.</p> <p>Introduction to aerodynamics, history of Flight, Newton's Laws of Motion, Bernoulli's Principle, four forces of Flight three axes of Flight, how they apply to drone Flight.</p> <p>Introduction to 3D printer and its software for designing various types of propellers.</p>

Professional Skill 21 Hrs; Professional Knowledge 06 Hrs	Identify and test various electronic SMD components using proper measuring instruments and Identify, place, solder and de-solder and different SMD discrete components and ICs package with due care and following safety norms using proper tools/setup. (Mapped NOS: ELE/N7308)	21 Identify of different types of SMD Components like resistance, capacitance, diode and inductor. 22 Measure different components values using SMD Technology Kit, Tweezers and DMM. 23 Identify of different types of SMD IC packages. 24 Explore and configure SMD soldering and de-soldering rework station. 25 Practice soldering and de-soldering the SMD components on the PCB. 26 Practice soldering and de-solder various IC's of different packages.	Knowledge about soldering station, soldering tools, soldering iron, soldering wicks, soldering temperature etc. Different types of soldering guns, related to Temperature and wattages, types of tips.
Professional Skill 42 Hrs; Professional Knowledge 12 Hrs.	Measure different type electrical parameters and record the data related with drone hardware. (Mapped NOS: ELE/N7005)	27 Identify the type of electronic instruments. 28 Measure the resistance, Voltage, Current through series and parallel connected networks using multi meter. 29 Measure AC and DC voltage using Digital Multi-meter. 30 Measure AC and DC current using Digital Multi-meter. 31 Measure frequency using Digital Multi-meter. 32 Measure the analog signals like of peak to peak voltage, frequency, time period, and duty cycle using of DSO. 33 Measure the frequency and level of RF signals using of spectrum analyzer. 34 Practice function generator and Arbitrary Waveform Generator.	Introduction of electrical components resistance, capacitance, inductance, diode, and transistor. Introduction of electrical parameters like DC voltage, DC current, AC voltage, AC current, frequency, duty cycle and Introduction to electrical and electronic measuring instruments. Working Principle of multimeter, digital storage oscilloscope, spectrum and waveform generator.
Professional Skill 21 Hrs; Professional Knowledge 06 Hrs.	Identification of different type of batteries, battery specifications and their charging techniques used in drone. (Mapped NOS: ELE/N9401)	35 Identify different type of batteries Li-ion and Li-Po. 36 Record and recognize different battery specifications. 37 Explore different charging techniques to charge batteries. 38 Measure and record different parameters of batteries using Battery management platform. 39 Inspect battery packs faults for bulges or leakage. 40 Identify fault related with chargers such as visible damage, voltage and current.	Introduction of different types of batteries used in drone. Understand different specifications and their significance of batteries.  Different charging circuits or batteries, What is battery management system (BMS) and different Building Blocks of BMS.

		<p>41 Measure and record different parameters of charging controller using software.</p> <p>42 Calculate maximum discharge and battery capacities in order calculate flight time.</p>	
Professional Skill 42 Hrs; Professional Knowledge 12Hrs	Test different sensors, their characteristics and repair which are commonly used in different drones. (Mapped NOS: ELE/N7308)	<p>43 Identify and measure condition of drone sensors.</p> <p>44 Explore different converters like V/I, I/V, F/V, V/F.</p> <p>45 Verify frequency response of low pass and high pass filters.</p> <p>46 Test and measure different amplifier functions.</p> <p>47 Measure and record the resistance, voltage, current and frequency of different sensors used in drone.</p> <p>48 Test &amp; measure accelerometers, inertial measurement units, tilt and lidar sensor, gyro sensor.</p> <p>49 Write and upload computer code to FCB to test sensors results.</p> <p>50 Calibrate the compass, Lidar, and gyro sensor.</p> <p>51 Measure and record angular rate, force, and magnetic field through IMU.</p> <p>52 Perform amplification of low power signals using current, power, instrumentation, differential, inverting, non-inverting and buffer amplifier circuits.</p>	<p>Introduction of different sensors used in drone like accelerometers, inertial measurement units, tilt and lidar sensor, gyro sensor. Principle of operation of various sensors used in drone; their roles and characteristics. Selection of appropriate sensor as per requirement.</p> <p>Understanding and importance of signal conditioning like voltage to current, current to voltage, frequency to voltage and voltage to frequency convertor, inverting amplifier, non-inverting amplifier, instrumentation amplifier, differential amplifier, power amplifier, current amplifier. How to calibrate Compass sensor, Lidar Sensor, Gyro sensor. Concept of sensor calibration and using sensors in digital &amp; analog mode.</p>
Professional Skill 42 Hrs; Professional Knowledge 12Hrs	Identify, select and test hardware assembly, driver for BLDC motors. (Mapped NOS: ELE/N9402)	<p>53 Identify different BLDC motors and their specifications</p> <p>54 Inspect and test BLDC Motor driver circuit.</p> <p>55 Measure and record speed-torque characteristics of BLDC Motor.</p> <p>56. Explore driving circuit of DC, BLDC and servo motors.</p> <p>57. Perform running and reversing phenomenon of BLDC Motor.</p> <p>58. Demonstration speed control of BLDC Motor using PWM technique.</p> <p>59. Practice Inverted pendulum balancing using programming technique and PID tuning.</p> <p>60. Measure thrust to weight ratio and payload.</p>	<p>Introduction to different motors like DC, BLDC, servo motors, working, understanding its functioning. Studying BLDC motor using PWM techniques, speed torque characteristics, degree of freedom in drone.</p> <p>Performing mathematical calculations like payload calculation, speed control techniques, thrust to weight ratio. Introduction of Inverted Pendulum and PID control. PWM Duty operation and Motor control by Encoder counter.</p>

<p>Professional Skill 21 Hrs; Professional Knowledge 06 Hrs</p>	<p>Inspect, test and execute GPS navigation and telemetry module, different RF blocks and antennas used in RF transmitter and receiver. (Mapped NOS: ELE/N7308)</p>	<ol style="list-style-type: none"> <li>61. Identify different antennas like patch, helical, and omnidirectional.</li> <li>62. Record and plot radiation pattern of different antennas.</li> <li>63. Measure directivity of the antenna.</li> <li>64. Identify the characteristics of RF circuit blocks like amplifier and filters.</li> <li>65. Configure and operate 433MHz and 2.4 GHz RC transmitter and receiver.</li> <li>66. Perform and check connectivity of transmitter and receiver used in drone.</li> <li>67. Understand GPS and its hardware interfacing with FCB.</li> <li>68. Connect and Measure and record data of GPS module to determine latitude &amp; longitude.</li> <li>69. Perform experiment to record, GPGGA, GPGLL, GPGSA, GPGSV, GPRMC and GPVTG values.</li> </ol>	<p>Various types of antennas used for drones and their characteristics. Introduction of antenna radiation pattern and directivity. Fundamentals of MIC amplifier and different filter used in RF range.</p> <p>Introduction to RF signals and components used for RC transmitter and receiver. Fundamentals of GPS and concept of navigation systems. Usage of signals from GPS satellites to determine latitude, longitude and altitude</p>
<p>Professional Skill 21 Hrs; Professional Knowledge 06 Hrs</p>	<p>Test and troubleshoot Flight Controller Board (FCB), Electronic Speed Controller (ESC) and its associated peripherals. (Mapped NOS: ELE/N9403)</p>	<ol style="list-style-type: none"> <li>70. Identify different flight control board and electronic speed control.</li> <li>71. Perform programming and configure flight control board (FCB).</li> <li>72. Identify, explore and test interconnectivity of different peripheral with FCB.</li> <li>73. Establish connection of FCB with motor, GPS, ESC and sensors.</li> <li>74. Configure, test and record FCB with battery to monitor battery level and perform return to home operation.</li> <li>75. Perform and carry out drone leveling using IMU sensor.</li> <li>76. Perform calibration of compass, Lidar, and gyro sensor.</li> <li>77. Test communication link between FCB and RF transceiver.</li> <li>78. Write and upload computer code to FCB to test sensors results.</li> <li>79. Test and record data of motor connectivity with ESC.</li> </ol>	<p>Introduction to Flight controller boards and its connectivity with different peripherals like sensors, ESC, GPS, RF module. Introduction Electronic Speed Controller and its connection with motor. ESC configurations using FCB to control speed and direction of motor.</p> <p>Introduction to flight control box and various commands used in it. Configuration techniques for FCB with various motors, GPS etc.</p>

		<p>80. Perform motor rotation using FCB and ESC.</p> <p>81. Test signal flow into drone to test ESC parameters on FCB to check its operation.</p> <p>82. Write and upload computer code to FCB to ESC working.</p>	
<p>Professional Skill 42 Hrs; Professional Knowledge 12Hrs</p>	<p>Calibrate and troubleshoot drone gimbal and drone payload. (Mapped NOS: ELE/N9404)</p>	<p>83 Identify the different types of drones and its application in different areas.</p> <p>84 Identify different features and controls of HD and thermal image camera.</p> <p>85 Test and install Gimbal camera assembly.</p> <p>86 Perform and test Gimbal stabilization</p> <p>87 Perform drone camera control using x, y, and z axes rotation.</p> <p>88 Test and install different cameras on gimbal assembly.</p> <p>89 Practice remote sensing, surveying &amp; mapping, photogrammetry and precision agriculture using HD and thermal image camera.</p> <p>90 Identify and record different application drones and their logged data for investigation.</p>	<p>Fundamental applications of various types of drones. Implementation and handling of HD and thermal image camera for remote sensing and mapping. Introduction to photogrammetry. Image recognition with OpenCV using the drone camera. Fundamental techniques for stabilizing Gimbal.</p>
<p>Professional Skill 42 Hrs; Professional Knowledge 12Hrs</p>	<p>Identify and resolve common error messages and corrections by software debugging. (Mapped NOS: ELE/N9405)</p>	<p>91 Identify bugs in the software program as per the algorithms used and the libraries.</p> <p>92 Resolve common error messages and apply the correct logic.</p> <p>93 Perform firmware configuration and updates.</p> <p>94 Download and Install App / Menu / Planning / Set-up / Flight / Application.</p> <p>95 Demonstration and perform base station software to debugging to get GPS and flight data.</p> <p>96 Perform experiments on software debug tool use to identify coding errors at different stages.</p> <p>97 Setup python and Arduino environment.</p> <p>98 Remote automatic drone operation using Python.</p>	<p>Introduction to software debug tool use to identify coding errors at different stages of development.</p> <p>Introduction to various drone operation using Python and Arduino and setup development environment. Firmware and hardware integration with common errors and their solutions.</p> <p>Introduction to software debugging tools and how to identify cause of coding errors. Introduction to ground base station assembly Introduction to preventive measures for drones.</p>

		<p>99 Knowledge and advantage of preventative maintenance of drone.</p> <p>100. Diagnose problems using Log Data / Analyze Data flash Log Data / Remote Communication Log Data / Save and Execute Log Data.</p> <p>101 Upgrade/downgrade drone firmware Identify error message and resolve approach.</p>	
<p>Professional Skill 21 Hrs; Professional Knowledge 06 Hrs</p>	<p>Inspect, test and execute primary and secondary servicing with troubleshoot malfunctioning, and repair issues discovered. (Mapped NOS: ELE/N7005)</p>	<p>102 Perform primary and secondary servicing based upon the checklist.</p> <p>103 Test and diagnose drone after 100 hours of flying for preventive maintenance.</p> <p>104 Test and diagnose drone after 500 hours of flying.</p> <p>105 Knowledge about drone troubleshooting check list like Equipment check, System reset, calibration, Motor Troubleshooting, Gimbal rotation, Battery Maintenance, and RF Signal and hardware.</p> <p>106 Diagnose the common drone problem like GPS signals are blocked , Decreased battery life, Wrong direction during flight, Flight Planning, Mechanical issue, and Firmware issue.</p> <p>107 Inspect drone before and after each flight.</p> <p>108 First time drone hardware assembly and test. (03 hrs.)</p> <p>109 Test, locate the fault and repair a wiring of drone.</p> <p>110 Check bent or cracked on legs and feet of the drone.</p> <p>111 Demonstration drone wiring connections with different parts.</p> <p>112 Perform takeoff/Landing operation and identify faults in system.</p>	<p>Fundamentals of primary and secondary services. Basics of Gimbal handling and its maintenance. Fundamentals of handling errors rise from GPS. Introduction to battery life maintenance, flight path monitoring. Studying throttle control by moving in either direction. Concept of Visual Inspection and Why Is It Important. Understand the various checks to be carried out to ensure the alignment of control surfaces..</p>



---

**Drone Technician - Safety Rules and Regulations**

---

---

**Familiar with industrial training institute**

---

**Objectives:** At the end of this lesson you shall be able to

- explain about DGT affiliated institutions under MSDE
  - familiarise with working of ITI using organisational chart of ITI
  - state the function of store procedures in training institutes.
- 

**Introduction****Directorate General of Training (DGT)**

Directorate General of Training (DGT) in Ministry of Skill Development & Entrepreneurship is an apex organization for development and coordination of the vocational training including Women's Vocational Training of the employable youth in the country and to provide skilled manpower to the economy.

Two verticals of Directorate General of Employment & Training (DGE&T) working under Deputy Director General (Training) & Deputy Director General (Apprenticeship Training) along with their support systems were transferred to Ministry of Skill Development & Entrepreneurship (MSDE).

DGT affiliated institutions offers a wide range of training courses catering to the needs of different segments in the Labour market. Courses are available for school leavers, ITI pass outs, ITI instructors, industrial workers, technicians, junior and middle level executives, supervisors/foremen, women, physically disabled persons and SC/STs.

It also conducts training oriented research and develops instructional media packages for the use of trainees and instructors etc.

DGT acts a secretariat and implementing arm of National Council for Vocational Training (NCVT).

**Training Institutes under DGT**

- 13350 Industrial Training institutes (ITIs)
- 31 Central Institutes
- 10 Advanced Training Institutes (ATIs)
- 2 ATI-EPIs (Advanced Training Institutes - Electronic Process Instrumentation)
- 2 Foremen Training Institutes (FTIs)
- 1 Central Training Institutes (CTI)
- 1 National Vocational Training Institute (NVTI) for Women
- 15 Regional Vocational Training Institutes (RVTIs) for Women
- 12 Private Institute for Training of Trainers (IToTs)
- 2 State Government IToTs
- Central Staff Training and Research Institute (CSTARI)
- National Instructional Media Institute (NIMI)

---

**Familiar with the working of Industrial Training Institute system including stores procedures**

---

**Objectives:** At the end of this lesson you shall be able to

- to familiarise with working of ITI
  - identify the staff structure of the institute
  - identify the available trades in the institute and their function
  - brief about the stores procedure.
- 

The industrial training institute throughout India follow the same syllabus pattern given by the National council for Vocational Training (NCVT). In India there are about 13,350 Government ITIs and Private ITI 's Based on the Govt. of India, Ministry of Skill Development and Entrepreneurship (MSDE) Annual report of 2016-2017. The Government Industrial Training Institute in each state work under the Directorate of Employment and Training which is a department under the Labour Ministry in most of the states.

The head of the industrial training institute is the Principal, under whom there is one vice-principal, Group

Instructor(s) Training officers and a number of Vocational Instructor(s) Assitant Training Officer(s) and Junior Training Officer and so on as shown in the Organisation Chart of ITI. (Fig 1)

In every industrial training institute there is a store and the in charge of the store is storekeeper for inward and outward movement of tools, equipment and consumable. The instructor will indent the training requirement on receiving from stores, the instructor will issue the training requirement to the trainees according to the graded exercises as per syllabus.

Fig 1

# ORGANISATIONAL CHART OF ITI

PRINCIPAL/SUPERINTENDENT

TRAINING AND  
PLACEMENT OFFICER

VICE PRINCIPAL

GROUP INSTRUCTOR /  
TRAINING OFFICER

OFFICE SUPDT.

HOSTEL SUPDT. CUM  
PHYSICAL TRG. INSTRUCTOR  
HOSTEL CLERK  
CLASS IV STAFF FOR HOSTEL

STORE SUPDT.  
STOREKEEPER  
ASST. STOREKEEPER  
STORE ATTENDANT

VOC. INSTRUCTOR /  
JUNIOR TRAINING OFFICER

ACCOUNTANT  
CLERICAL STAFF  
CLASS IV STAFF  
FOR THE INSTITUTE

INSTRUCTOR FOR  
ALLIED TRADE / JTO  
DRAWING INSTRUCTOR  
MILLWRIGHT INSTRUCTOR  
METHEMATICS INSTRUCTOR  
A.V. INSTRUCTOR  
WORKSHOP ATTENDANT

SUPPORTING STAFF

MEDICAL OFFICER  
COMPOUNDER  
DRESSER

DT20N110111



**Importance of safety and general precautions observed in the industry/shop floor**

**Objectives:** At the end of this lesson you shall be able to

- state the importance of safety
- list out the safety precautions to be observed in a industry/shop floor
- list out the personal safety precautions to be observed in machine shop
- list out the safety precautions to be observed while working on the machines.

Generally accidents do not happen; they are caused. Most accidents are avoidable. A good craftsman, having a knowledge of various safety precautions, can avoid accidents to himself and to his fellow workers and protect the equipment from any damage. To achieve this, it is essential that every person should follow safety procedure. (Fig 1)

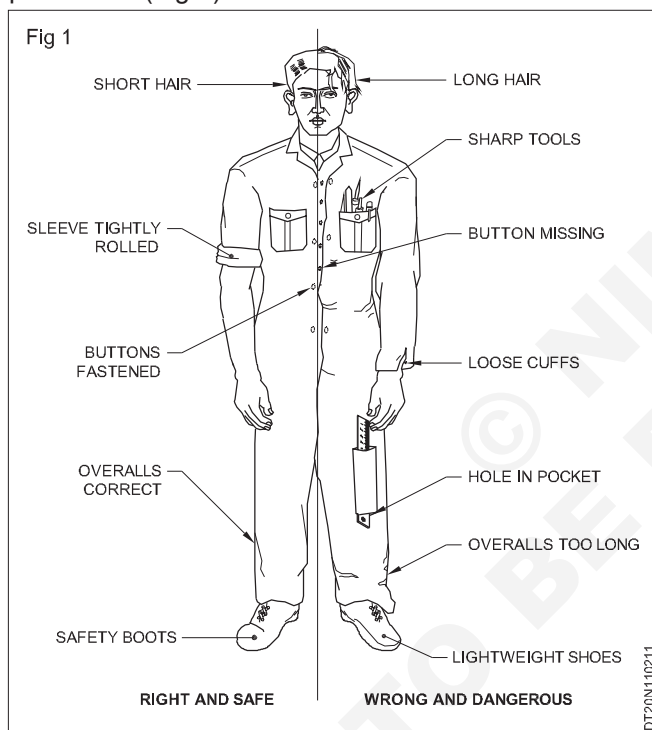

Safety in a workshop can be broadly classified into 3 categories.

- General safety
- Personal safety
- Machine safety

**General safety**

- Keep the floor and gangways clean and clear.
- Move with care in the workshop, do not run.
- Don't leave the machine which is in motion.
- Don't touch or handle any equipment/ machine unless authorised to do so.
- Don't walk under suspended loads.
- Don't cut practical jokes while on work.
- Use the correct tools for the job.
- Keep the tools at their proper place.

Wipe out split oil immediately.

Replace worn out or damaged tools immediately.

Never direct compressed air at yourself or at your co-worker.

Ensure adequate light in the workshop.

Clean the machine only when it is not in motion.

Sweep away the metal cuttings.

Know everything about the machine before you start it.

**Personal safety**

Wear a one piece overall or boiler suit.

Keep the overall buttons fastened.

Don't use ties and scarves.

Roll up the sleeves tightly above the elbow.

Wear safety shoes or boots

Cut the hair short.

Don't wear a ring, watch or chain.

Never lean on the machine.

Don't clean hands in the coolant fluid.

Don't remove guards when the machine is in motion.

Don't use cracked or chipped tools.

Don't start the machine until

- the workpiece is securely mounted
- the feed machinery is in the neutral
- the work area is clear.

Don't adjust clamps or holding devices while the machine is in motion.

Never touch the electrical equipment with wet hands.

Don't use any faulty electrical equipment.

Ensure that electrical connections are made by an authorised electrician only.

Concentrate on your work. Have a calm attitude.

Do things in a methodical way.

Don't engage yourself in conversation with others while concentrating on your job.

Don't distract the attention of others.

Don't try to stop a running machine with hands.

### Machine safety

Switch off the machine immediately if something goes wrong.

Keep the machine clean.

Replace any worn out or damaged accessories, holding devices, nuts, bolts etc as soon as possible.

Do not attempt operating the machine until you know how to operate it properly.

Do not adjust tool or the workpiece unless the power is off.

Stop the machine before changing the speed.

Disengage the automatic feeds before switching off.

Check the oil level before starting the machine.

Never start a machine unless all the safety guards are in position.

Take measurements only after stopping the machine.

Use wooden planks over the bed while loading and unloading heavy jobs.

**Safety is a concept, understand it. Safety is a habit, cultivate it.**

## Approach on soft skills

**Objectives :** At the end of this lesson you shall be to

- state the concept of soft skill
- list the important common soft skills
- brief the employability aspect of training
- brief the further learning scope.

### Concept

Soft skills - refer to the cluster of personality traits, social graces, facility with language, personal habits, friendliness, and optimism that mark people to varying degrees. The same can also be defined as-ability to interact communicate positively & productively with others. Sometimes called "character skills".

More and more business are considering soft skills as important job criteria. Soft skills are used in personal and professional life. Hard skills/technical skills do not matter without soft skills.

### Common Soft Skills

- Strong work ethic
- Positive attitude
- Good communication skills
- Interpersonal skills
- Time management abilities
- Problem-solving skills
- Team work
- Initiative, Motivation
- Self-confidence
- Loyalty
- Ability to accept and learn from criticism

- Flexibility, Adaptability
- Working well under pressure

**Job area completion of training:** This highlights the employability aspect on completion of training. The trainee should be aware of various prospects available in present market scenario along with scope for self-employment. For example a trainee with NTC engineering trade may opt for:

**Various job available in different industries in India and Abroad.**

After successful completion of ITI training in any one of the engineering trade one can see appointment in engineering workshop/Factories (Public Sector, Private Sector and Government Industries) in India and Abroad as technician/Skilled worker.

### Self employment

One can start his own factory/ancillary unit or design products manufacture and become an entrepreneur.

### Further learning scope

- Apprentice training in designated trade.
- Craft Instructor certificate course.
- Diploma in relevant Engineering.

# Personal Protective Equipment (PPE)

**Objectives:** At the end of this lesson you shall be able to

- state what is personal protective equipment and its purpose
- name the two categories of personal protective equipment
- list the most common type of personal protective equipment
- list the conditions for selection of personal protective equipment.

## Personal Protective Equipment (PPE)

Devices, equipments, or clothing used or worn by the employees, as a last resort, to protect against hazards in the workplace. The primary approach in any safety effort is that the hazard to the workmen should be eliminated or the workmen through the use of personal protective controlled by engineering methods rather than protecting the workmen through the use of personal protective equipment (PPE). Engineering methods could include design change, substitution ventilation, mechanical handling, automation, etc. in situations where it is not possible to introduce any effective engineering methods for controlling hazards, the workman shall use appropriate types of PPE.

As changing times have modernized the workplace, government and advocacy groups have brought more safety standards to all sorts of work environments. The Factories Act, 1948 and several other labour legislations 1996 have provisions for effective use of appropriate types of PPE. Use of PPE is very important.

## Ways to ensure workplace safety and use personal protective equipment (PPE) effectively.

- Workers to get up-to date safety information from the regulatory agencies that oversees workplace safety in their specific area.
- To use all available text resources that may be in work area and for applicable safety information on how to use PPE best.
- When it comes to the most common types of personal protective equipment, like goggles, gloves or bodysuits, these items are much less effective if they are not worn at all times, or whenever a specific danger exists in a work process. Using PPE consistently will help to avoid some common kinds of industrial accidents.
- Personal protective gear is not always enough to protect workers against workplace dangers, Knowing more about the overall context of your activity can help to fully protect from anything that might threaten health and safety on the job.

- Inspection of gear thoroughly to make sure that it has the standard of quality and adequately protect the user should be continuously carried out.

## Categories of PPE-Small's'

Depending upon the nature of hazard, the PPE is broadly divided into the following two categories.

**Non- respiratory :** Those used for protection against injury from outside the body, i.e. for protecting the head, eye, face, hand, arm, foot, leg and other body parts

**Respiratory:** Those used for protection from harm due to inhalation of contaminated air.

They are to meet the applicable BIS (Bureau of Indian Standards) standards for different types of PPE.

The guidelines on 'Personal Protective Equipment' is issued to facilitate the plant management in maintaining an effective programme with respect to protection of persons against hazards, which cannot be eliminated or controlled by engineering methods listed in table 1.

Table 1

No	Title
PPE1	Helmet
PPE2	Safety footwear
PPE3	Respiratory protective equipment
PPE4	Arms and hands protection
PPE5	Eyes and face protection
PPE6	Protective clothing and coverall
PPE7	Ears protection
PPE8	Safety belt harness

Personal protective equipments and their uses and hazards are listed in Table 2

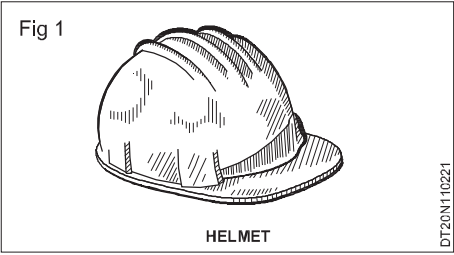
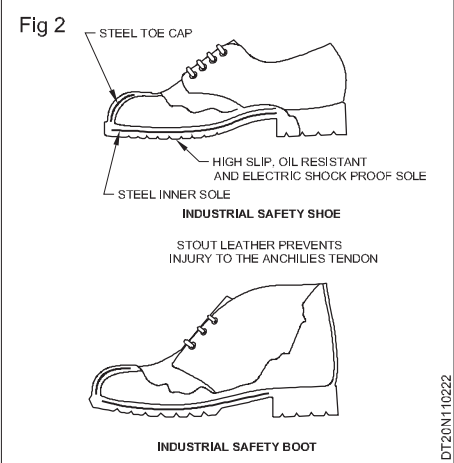
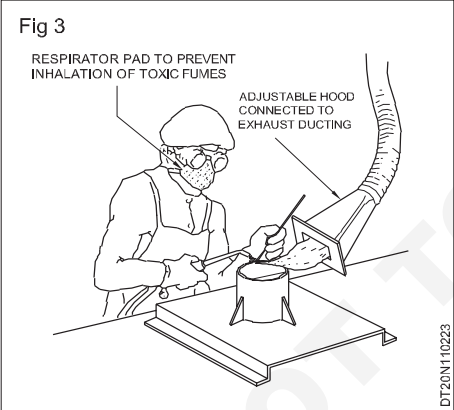
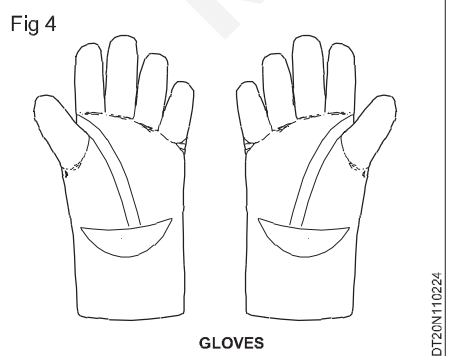
Types of protection	Hazards	PPE to be used
<p>Head protection (Fig 1)</p> 	<ol style="list-style-type: none"> <li>1 Falling objects</li> <li>2 Striking against objects</li> <li>3 Spatter</li> </ol>	<p>Helmets</p>
<p>Foot protection (Fig 2)</p> 	<ol style="list-style-type: none"> <li>1 Hot spatter</li> <li>2 Falling objects</li> <li>3 Working wet area</li> </ol>	<p>Leather leg guards Safety shoes Gum boots</p>
<p>Nose (Fig 3)</p> 	<ol style="list-style-type: none"> <li>1 Dust particles</li> <li>2 Fumes/gases/ vapours</li> </ol>	<p>Nose mask</p>
<p>Hand Protection (Fig 4)</p> 	<ol style="list-style-type: none"> <li>1 Heat burn due to direct contact</li> <li>2 Blows spark moderate heat</li> <li>3 Electric shock</li> </ol>	<p>Hand gloves</p>

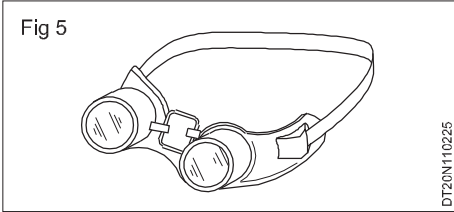
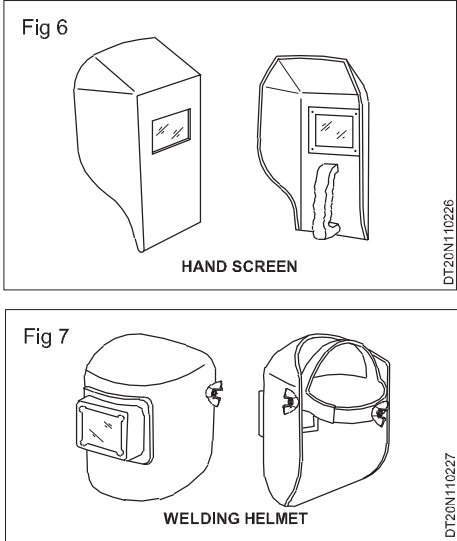
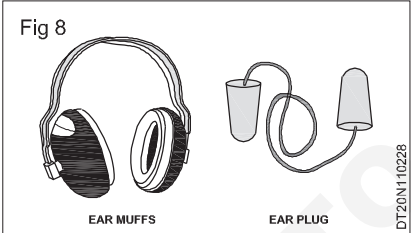
Types of protection	Hazards	PPE to be used
<p>Eye protection (Fig 5)</p>  <p>Fig 5</p> <p style="text-align: right; font-size: small;">DT20N110225</p>	<ol style="list-style-type: none"> <li>1 Flying dust particles</li> <li>2 UV rays, IR rays heat and High amount of visible</li> </ol>	<p>Goggles Face shield Hand shield Head shield</p>
<p>Face protection (Fig 6 &amp; Fig 7)</p>  <p>Fig 6</p> <p style="text-align: center; font-size: small;">HAND SCREEN</p> <p style="text-align: right; font-size: small;">DT20N110226</p> <p>Fig 7</p> <p style="text-align: center; font-size: small;">WELDING HELMET</p> <p style="text-align: right; font-size: small;">DT20N110227</p>	<ol style="list-style-type: none"> <li>1 Spark generated during Welding, grinding</li> <li>2 Welding spatter striking</li> <li>3 Face protection from UV rays</li> </ol>	<p>Face shield Head shield with or without ear muff Helmets with welders Screen for welders</p>
<p>Ear protection (Fig 8)</p>  <p>Fig 8</p> <p style="text-align: center; font-size: small;">EAR MUFFS      EAR PLUG</p> <p style="text-align: right; font-size: small;">DT20N110228</p>	<ol style="list-style-type: none"> <li>1 High noise level</li> </ol>	<p>Ear plug Ear muff</p>

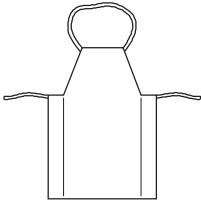
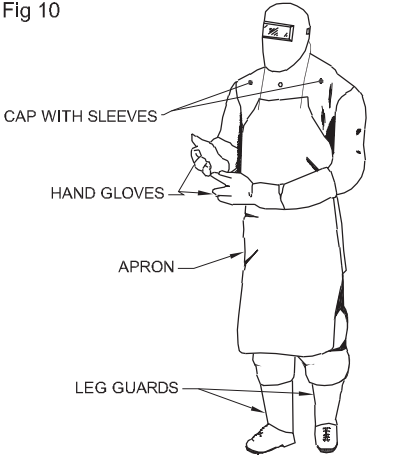
Types of protection	Hazards	PPE to be used
<p>Body protection (Fig 9, &amp; Fig 10)</p> <div data-bbox="108 202 560 457"> <p>Fig 9</p>  <p>APRON</p> <p>DT20N110229</p> </div> <div data-bbox="108 478 560 993"> <p>Fig 10</p>  <p>CAP WITH SLEEVES</p> <p>HAND GLOVES</p> <p>APRON</p> <p>LEG GUARDS</p> <p>LEG GUARDS</p> <p>DT20N11022A</p> </div>	<p>1 Hot particles</p>	<p>Leather aprons</p>

### Quality of PPE's

PPE must meet the following criteria with regard to its quality-provide absolute full protection against possible hazard and PPE's be so designed and manufactured out of materials that it can withstand the hazards against which it is intended to be used.

### Selection of PPE's requires certain conditions

- Nature and severity of the hazard
- Type of contaminant, its concentration and location of contaminated area with respect to the source of respirable air
- Expected activity of workman and duration of work, comfort of workman when using PPE
- Operating characteristics and limitation of PPE
- Easy of maintenance and cleaning
- Conformity to Indian / International standards and availability of test certificate.

### Proper use of PPEs

Having selected the proper type of PPE, it is essential that the workman wears it. Often the workman avoids using PPE. The following factors influence the solution to this problem.

- The extent to which the workman understands the necessity of using PPE
- The ease and comfort with which PPE can be worn with least interference in normal work procedures
- The available economic, social and disciplinary sanctions which can be used to influence the attitude of the workman
- The best solution to this problem is to make wearing of PPE' mandatory for every employee.
- In other places, education and supervision need to be intensified. When a group of workmen are issued PPE for the first time.



---

## **First-aid**

---

**Objectives:** At the end of this lesson you shall be able to

- **state what is first aid**
  - **list the key aims of first aid**
  - **explain the ABC of the first aid**
  - **brief how to give first-aid for a victim who need first aid.**
- 

First aid is defined as the immediate care and support given to an acutely injured or ill person, primarily to save life, prevent further deterioration or injury, plan to shift the victims to safer places, provide best possible comfort and finally help them to reach the medical centre/ hospital through all available means. It is an immediate life-saving procedure using all resources available within reach.

Imparting knowledge and skill through institutional teaching at younger age group in schools, colleges, entry point at industry level is now given much importance. Inculcating such habits at early age, helps to build good healthcare habits among people.

First aid procedure often consists of simple and basic life saving techniques that an individual performs with proper training and knowledge.

The key aims of first aid can be summarized in three key points:

- **Preserve life:** If the patient was breathing, a first aider would normally place them in the recovery position, with the patient leant over on their side, which also has the effect of clearing the tongue from the pharynx. It also avoids a common cause of death in unconscious patients, which is choking on regurgitated stomach contents. The airway can also become blocked through a foreign object becoming lodged in the pharynx or larynx, commonly called choking. The first aider will be taught to deal with this through a combination of 'back slaps' and 'abdominal thrusts'. Once the airway has been opened, the first aider would assess to see if the patient is breathing.
- **Prevent further harm:** Also sometimes called prevent the condition from worsening, or danger of further injury, this covers both external factors, such as moving a patient away from any cause of harm, and applying first aid techniques to prevent worsening of the condition, such as applying pressure to stop a bleed becoming dangerous.
- **Promote recovery:** First aid also involves trying to start the recovery process from the illness or injury, and in some cases might involve completing a treatment, such as in the case of applying a plaster to a small wound.

### **Training**

Basic principles, such as knowing to use an adhesive bandage or applying direct pressure on a bleed, are often acquired passively through life experiences. However, to provide effective, life-saving first aid interventions requires instruction and practical training. This is

especially true where it relates to potentially fatal illnesses and injuries, such as those that require cardiopulmonary resuscitation (CPR); these procedures may be invasive, and carry a risk of further injury to the patient and the provider. As with any training, it is more useful if it occurs before an actual emergency, and in many countries, emergency ambulance dispatchers may give basic first aid instructions over the phone while the ambulance is on the way. Training is generally provided by attending a course, typically leading to certification. Due to regular changes in procedures and protocols, based on updated clinical knowledge, and to maintain skill, attendance at regular refresher courses or re-certification is often necessary. First aid training is often available through community organization such as the Red cross and St. John ambulance.

### **ABC of first aid**

ABC stands for airway, breathing and circulation.

- **Airway:** Attention must first be brought to the airway to ensure it is clear. Obstruction (choking) is a life-threatening emergency.
- **Breathing:** Breathing if stops, the victim may die soon. Hence means of providing support for breathing is an important next steps. There are several methods practiced in first aid.
- **Circulation:** Blood circulation is vital to keep person alive. The first aiders now trained to go straight to chest compressions through CPR methods.

When providing first aid one needs to follow some rule. There are certain basic norms in teaching and training students in the approach and administration of first aid to sick and injured.

### **Not to get panic**

Panic is one emotion that can make the situation more worse. People often make mistake because they get panic. Panic clouds thinking and causes mistakes. First aider need calm and collective approach. If the first aider himself is in a state of fear and panic gross mistakes may result. It's far easier to help the suffering, when they know what they are doing, even if unprepared to encounter a situation. Emotional approach and response always lead to wrong doing and may cloud one to do wrong procedures. Hence be calm and focus on the given institution. Quick and confident approach can lessen the effect of injury.

### **Call medical emergencies**

If the situation demands, quickly call for medical assistance. Prompt approach may save the life.

## Surroundings play vital role

Different surroundings require different approach. Hence first aider should study the surrounding carefully. In other words, one need to make sure that they are safe and are not in any danger as it would be of no help that the first aider himself get injured.

## Do no harm

Most often over enthusiastically practiced first aid viz. administering water when the victim is unconscious, wiping clotted blood (which acts as plug to reduce bleeding), correcting fractures, mishandling injured parts etc., would leads to more complication. Patients often die due to wrong FIRST AID methods, who may otherwise easily survive. Do not move the injured person unless the situation demands. It is best to make him lie wherever he is because if the patient has back, head or neck injury, moving him would causes more harm.

This does not mean do nothing. It means to make sure that to do something the care givers feel confident through training would make matters safe. If the first aider is not confident of correct handling it is better not to intervene or do it. Hence moving a trauma victim, especially an unconscious one, need very careful assessment. Removals of an embedded objects (Like a knife, nail) from the wound may precipitate more harm (e.g. increased bleeding). Always it is better to call for help.

## Reassurance

Reassure the victim by speaking encouragingly with him.

## Stop the bleeding

If the victim is bleeding, try to stop the bleeding by applying pressure over the injured part.

## Golden hours

India have best of technology made available in hospitals to treat devastating medical problem viz. head injury, multiple trauma, heart attack, strokes etc, but patients often do poorly because they don't gain access to that technology in time. The risk of dying from these conditions, is greatest in the first 30 minutes, often instantly. This period is referred to as Golden period. By the time the patient reach hospitals, they would have passed that critical period. First aid care come handy to save lives. It helps to get to the nearest emergency room as quickly as possible through safe handling and transportation. The shorter that time, the more likely the best treatment applied.

## Maintain the hygiene

Most importantly, first aider need to wash hands and dry before giving and first aid treatment to the patient or wear gloves in order to prevent infection.

## Cleaning and dressing

Always clean the wound thoroughly before applying the bandage lightly wash the wound with clean water.

## Not to use local medications on cuts or open wounds

They are more irritating to tissue than it is helpful. Simple dry cleaning or with water and some kind of bandage are best.

## CPR (Cardio-Pulmonary Resuscitation) can be life-sustaining

CPR can be life sustaining. If one is trained in CPR and the person is suffering from choking or finds difficulty in breathing, immediately begin CPR. However, if one is not trained in CPR, do not attempt as you can cause further injury. Bur some people do it wrong. This is a difficult procedure to do in a crowded area. Also there are many studies to suggest that no survival advantage when bystanders deliver breaths to victims compared to when they only do chest compressions. Second, it is very difficult to carry right maneuver in wrong places. But CPR, if carefully done by highly skilled first aiders is a bridge that keeps vital organs oxygenated until medical team arrives.

## Declaring death

It is not correct to declare the victim's death at the accident site. It has to be done by qualified medical doctors.

## How to report an emergency?

Reporting an emergency is one of those things that seems simple enough, until actually when put to use in emergency situations. A sense of shock prevail at the accident sites. Large crowd gather around only with inquisitive nature, but not to extend helping hands to the victims. This is common in road side injuries. No passerby would like to get involved to assist the victims. Hence first aid management is often very difficult to attend to the injured persons. The first aiders need to adapt multitask strategy to control the crowd around, communicate to the rescue team, call ambulance etc., all to be done simultaneously. The mobile phones helps to a greater deal for such emergencies. Few guidelines are given below to approach the problems.

Assess the urgency of the situation. Before you report an emergency, make sure the situation is genuinely urgent. Call for emergency services if you believe that a situation is life-threatening or otherwise extremely disruptive.

- A crime, especially one that is currently in progress. If you're reporting a crime, give a physical description of the person committing the crime.
- A fire - If you're reporting a fire, describe how the fire stated and where exactly it is located. If someone has already been injured or is missing, report that as well.
- A life-threatening medical emergency, explain how the incident occurred and what symptoms the person currently displays.
- A car crash - Location, serious nature of injures, vehicle's details and registration, number of people involved etc.



## Call emergency service

The emergency number varies - 100 for Police & Fire. 108 for Ambulance.

## Report your location

The first thing the emergency dispatcher will ask is where you are located, so the emergency services can get there as quickly as possible. Give the exact street address, if you're not sure of the exact address, give approximate information.

## Give the dispatcher your phone number

This information is also imperative for the dispatcher to have, so that he or she is able to call back if necessary.

## Describe the nature of the emergency

Speak in a calm, clear voice and tell the dispatcher why you are calling. Give the most important details first, then answer the dispatcher's follow-up question as best as you can.

**Do not hang up the phone** until you are instructed to do so. Then follow the instructions you were given.

## Basic first aid

Basic first aid refers to the initial process of assessing and addressing the needs of someone who has been injured or is in physiological distress due to choking, a heart attack, allergic reactions, drugs or other medical emergencies. Basic first aid allows one to quickly determine a person's physical condition and the correct course of treatment.

## Important guideline for first aiders

### Evaluate the situation

Are there things that might put the first aider at risk. When faced with accidents like fire, toxic smoke, gasses, an unstable building, live electrical wires or other dangerous scenario, the first aider should be very careful not to rush into a situation, which may prove to be fatal.

### Remember A-B-Cs

The ABCs of first aid refer to the three critical things the first aiders need to look for.

- Airway - Does the person have an unobstructed airway?
- Breathing - Is the person breathing?
- Circulation - Does the person show a pulse at major pulse points (wrist, carotid artery, groin)

### Avoid moving the victim

Avoid moving the victim unless they are in immediate danger. Moving a victim will often make injuries worse, especially in the case of spinal cord injuries.

## Call emergency services

Call for help or tell someone else to call for help as soon as possible. If alone in at the accident scene, try to establish breathing before calling for help, and do not leave the victim alone unattended.

## Determine responsiveness

If a person is unconscious, try to rouse them by gently shaking and speaking to them.

**If the person remains unresponsive, carefully roll them on the side (recovery position) and open his airway.**

- Keep head and neck aligned.
- Carefully roll them onto their back while holding his head.
- Open the airway by lifting the chin. (Fig 1)

Fig 1



## Look, listen and feel for signs of breathing

Look for the victim's chest to raise and fall, listen for sounds of breathing.

If the victim is not breathing, see the section below

- If the victim is breathing, but unconscious, roll them onto their side, keeping the head and neck aligned with the body. This will help drain the mouth and prevent the tongue or vomit from blocking the airway.

## Check the victim's circulation

Look at the victim's colour and check their pulse (the carotid artery is a good option; it is located on either side of the neck, below the jaw bone). If the victim does not have a pulse, start CPR.

## Treat bleeding, shock and other problems as needed

After establishing that the victim is breathing and has a pulse, next priority should be to control any bleeding. Particularly in the case of trauma, preventing shock is the priority.

- **Stop bleeding:** Control of bleeding is one of the most important things to save a trauma victim. Use direct pressure on a wound before trying any other method of managing bleeding.
- **Treat shock:** Shock, a loss of blood flow from the body, frequently follows physical and occasionally psychological trauma. A person in shock will frequently have ice cold skin, be agitated or have an altered mental status, and have pale colour to the skin around the face and lips. Untreated, shock can be fatal. Anyone who has suffered a severe injury or life-threatening situation is at risk for shock.
- **Choking victim:** Choking can cause death or permanent brain damage within minutes.

- **Treat a burn:** Treat first and second degree burns by immersing or flushing with cool water. Don't use creams, butter or other ointments, and do not pop blisters. Third degree burns should be covered with a damp cloth. Remove clothing and jewellery from the burn, but do not try to remove charred clothing that is stuck to burns.
- **Treat a concussion:** If the victim has suffered a blow to the head, look for signs of concussion. Common symptoms are: loss of consciousness following the injury, disorientation or memory impairment, vertigo, nausea, and lethargy.
- **Treat a spinal injury victim:** If a spinal injury is suspected, it is especially critical, not move the victim's head, neck or back unless they are in immediate danger.

### Stay with the victim until help arrives

Try to be a calming presence for the victim until assistance can arrive.

### Unconsciousness (COMA)

Unconscious also referred as Coma, is a serious life threatening condition, when a person lie totally senseless and do not respond to calls, external stimulus. But the basic heart, breathing, blood circulation may be still intact, or they may also be failing. If unattended it may lead to death.

The condition arises due to interruption of normal brain activity. The causes are too many.

- Shock (Cardiogenic, Neurogenic)
- Head injury (Concussion, Compression)
- Asphyxia (obstruction to air passage)
- Extreme of body temperature (Heat, Cold)
- Cardiac arrest (Heart attack)
- Stroke (Cerebro-vascular accident)
- Blood loss (Haemorrhage)
- Dehydration (Diarrohea & vomiting)
- Diabetes (Low or high sugar)
- Blood pressure (Very low or very high)
- Over dose of alcohol, drugs
- Poisoning (Gas, Pesticides, Bites)
- Epileptic fits (Fits)
- Hysteria (Emotional, Psychological)

The following symptoms may occur after a person has been unconscious:

- Confusion
- Drowsiness
- Headache
- Inability to speak or move parts of his or her body (see stroke symptoms)

- Light headedness
- Loss of bowel or bladder control (incontinence)
- Rapid heartbeat (palpitation)
- Stupor

### First aid

- Call EMERGENCY number.
- Check the person's airway, breathing, and pulse frequently. If necessary, begin rescue breathing and CPR.
- If the person is breathing and lying on the back and after ruling out spinal injury, carefully roll the person onto the side, preferably left side. Bend the top leg so both hip and knee are at right angles. Gently tilt the head back to keep the airway open. If breathing or pulse stops at any time, roll the person on to his back and begin CPR.
- If there is a spinal injury, the victims position may have to be carefully assessed. If the person vomits, roll the entire body at one time to the side. Support the neck and back to keep the head and body in the same position while you roll.
- Keep the person warm until medical help arrives.
- If you see a person fainting, try to prevent a fall. Lay the person flat on the floor and raise the level of feet above and support.
- If fainting is likely due to low blood sugar, give the person something sweet to eat or drink when they become conscious.

### DO NOT

- Do not give an unconscious person any food or drink.
- Do not leave the person alone.
- Do not place a pillow under the head of an unconscious person.
- Do not slap an unconscious person's face or splash water on the face to try to revive him.

**Loss of consciousness may threaten life if the person is on his back and the tongue has dropped to the back of the throat, blocking the airway. Make certain that the person is breathing before looking for the cause of unconsciousness. If the injuries permit, place the casualty in the recovery position with the neck extended. Never give anything by mouth to an unconscious casualty.**

Fig 2

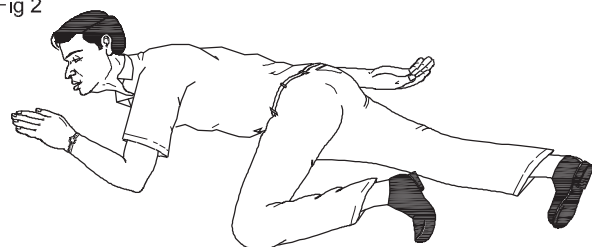

DT20N110312

### How to diagnose an unconscious injured person

- **Consider alcohol:** look for signs of drinking, like empty bottles or the smell of alcohol.
- **Consider epilepsy:** are there signs of a violent seizure, such as saliva around the mouth or a generally dishevelled scene?
- **Think insulin:** might the person be suffering from insulin shock (see 'How to diagnose and treat insulin shock')?
- **Think about drugs:** was there an overdose? Or might the person have under dosed - that is not taken enough of a prescribed medication?
- **Consider trauma:** is the person physically injured?
- **Look for signs of infection:** redness and/ or red streaks around a wound.
- **Look around for signs of Poison:** an empty bottle of pills or a snakebite wound.
- **Consider the possibility of psychological trauma:** might the person have a psychological disorder of some sort?
- Consider stroke, particularly for elderly people.
- Treat according to what you diagnose.

### Shock (Fig 3)

A severe loss of body fluid will lead to a drop in blood

pressure. Eventually the blood's circulation will deteriorate and the remaining blood flow will be directed to the vital organs such as the brain. Blood will therefore be directed away from the outer area of the body, so the victim will appear pale and the skin will feel ice cold.

Fig 3



**Guidelines for good shop floor maintenance**

**Objectives:** At the end of this lesson you shall be able to

- list the benefits of a shop floor maintenance
- state what is 5s
- list the benefits of 5s. Benefits of a shop floor maintenance.

Some of the benefits which may be derived from the utilization of a good Shop Floor Maintenance are as follows:

- Improved productivity
- Improved operator efficiencies.
- Improved support operations such as replenishment moves and transportation of work in process and finished goods.
- Reduction of scrap
- Better control of your manufacturing process
- More timely information to assist shop floor supervisors in managing their assigned production responsibilities.
- Reduction of down time due to better machine and tool monitoring.
- Better control of work in progress inventory, what is and where it is improved on time schedule performance.

**5S concept**

5S is a Japanese methodology for works place organisation. In Japanese it stands for seiri (SORT), seiton (SET), seiso (SHINE), seiketsu (STANDARDIZE) and shitsuke (SUSTAIN).

The list describes how to organize a work space for efficiency and effectiveness by identifying and storing the items used, maintaining the area and items, and

sustaining the new order. The list describes how to organize a work space for efficiency and effectiveness by identifying and storing the items used, maintaining the area and items, and sustaining the new order.

**5S Wheel (Fig 1)**

**The Benefits of the 5s system**

- Increases in productivity
- Increases in quality
- Reduction in cost

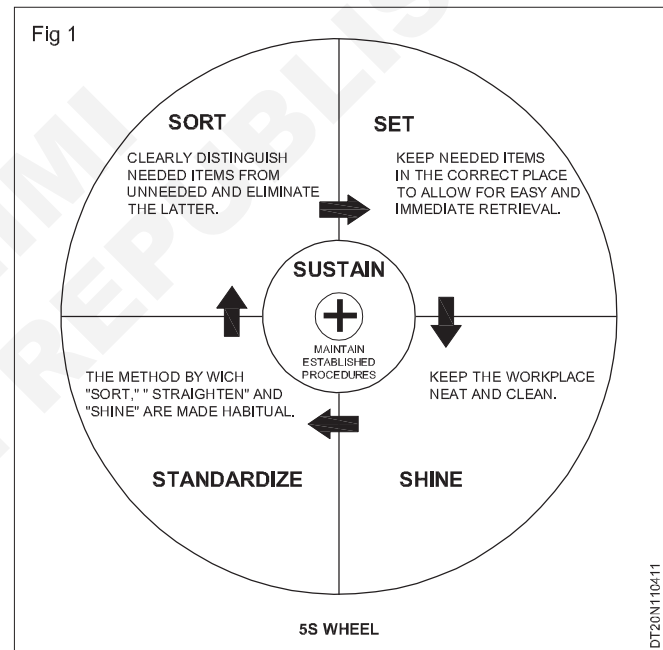

**Importance of housekeeping**

**Objectives:** At the end of this lesson you shall be able to

- list the steps involves in house keeping
- state good shop floor practices followed in industry Housekeeping.

The following activities to be performed for better up keep of working environment:

- 1 **Cleaning of shop floor:** Keep clean and free from accumulation of dirt and scrap daily
- 2 **Cleaning of Machines :** Reduce accidents to keep machines cleaned well
- 3 **Prevention of Leakage and spillage:** Use splash guards in machines and collecting tray
- 4 **Disposal of Scrap-** Empty scrap, wastage, swarf from respective containers regularly

- 5 **Tools Storage-** Use special racks, holders for respective tools
- 6 **Storage Spaces:** Identify storage areas for respective items. Do not leave any material in gangway
- 7 **Piling Methods-** Do not overload platform, floor and keep material at safe height.
- 8 **Material handling:** Use forklifts, conveyors and hoist according to the volume and weight of the package.

**Good shop floor practices followed in industry**

Good Shop floor practices are motivating action plans for improvement of the manufacturing process.

- All workers are communicated with daily target on manufacturing, activities.
- Informative charts are used to post production, quality and safety results compared to achievements.
- Workers are trained on written product quality standards.
- Manufactured parts are inspected to ensure adherence to quality standards.
- Production processes are planned by engineering to minimize product variation.
- 5s methods are used to organize the shop floor and production lines.
- Workers are trained on plant safety practices in accordance with Occupational Safety Health (OSH) standards.
- Workers are trained on "root cause" analysis for determining the causes of not following.
- A written preventive maintenance plan for upkeep of plant, machinery & equipment
- Management meets with plant employees regularly to get input on process improvements.
- Process Improvement Teams are employed to implement "best practices"

## Disposal of waste material

**Objectives:** At the end of this lesson you shall be able to

- state what is waste material
- list the waste materials in a work shop
- explain the methods of disposal of waste material
- state advantage of disposal of waste material
- state colour code for bins for waste segregation.

### Waste material

industrial waste is the waste produced by industrial activity such as that of factories, mills and mines.

### List of waste material (Fig 1)

- Cotton waste
- Metal chips of different material.
- Oily waste such as lubricating oil, coolant etc.
- Other waste such electrical, glass etc.

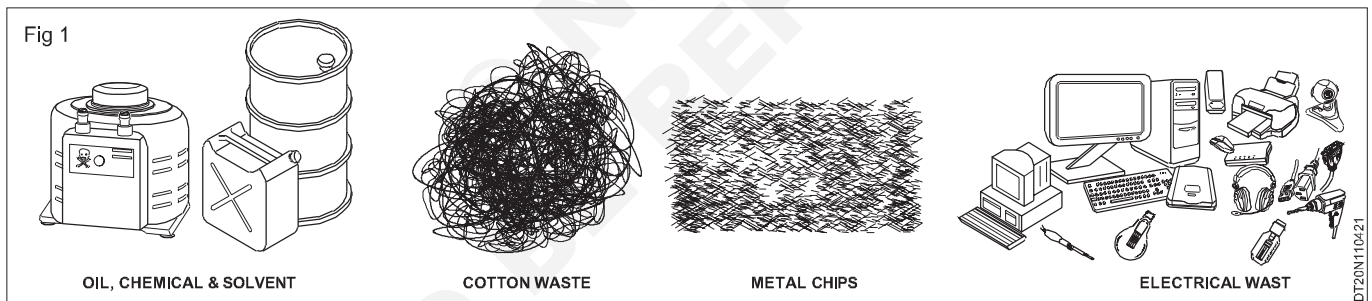

### Methods of waste disposal

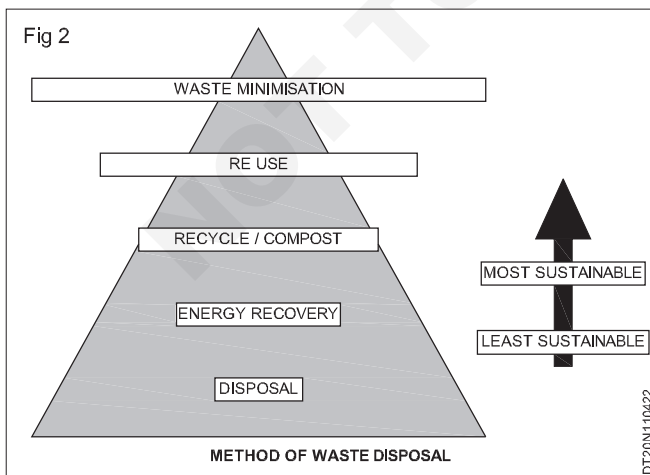

done by you. If you carry out recycling, you will save a lot of energy, resources and thereby reduce pollution.

### Composting

This is a natural process that is completely free of any hazardous by-products. This process involves breaking down the materials into organic compounds that can be used as manure.

### Landfills

Waste management through the use of landfills involves the use of a large area. This place is dug open and filled with the waste.

### Burning the waste material

If you cannot recycle or if there are no proper places for setting up landfills, you can burn the waste matter generated in your household. Controlled burning of waste at high temperatures to produce steam and ash is a preferred waste disposal technique.

### Recycling

Recycling is one of the most well known method of managing waste. It is not expensive and can be easily



### Advantage of waste disposal:

- Ensures workshop neat & tidy
- Reduces adverse impact on health
- Improves economic efficiency
- Reduce adverse impact on environment

### Incineration (Fig.3)

It is the process of controlled combustion of garbage to reduce it to incombustible matter, ash, waste gas and heat. It is treated and released into the environment (Fig.3). This reduced 90% volume of waste, some time the heat generated used to produce electric power.

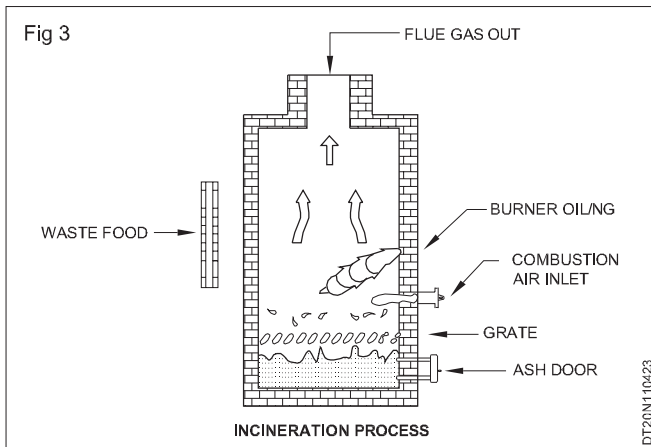

### Waste compaction

The waste materials such as cans and plastic bottles compact into blocks and send for recycling. This process space need, thus making transportation and positioning easy.

Colour code for bins for waste segregation given in Table-1

Table-1

Sl.No.	Waste Material	Color code
1	Paper	Blue
2	Plastic	Yellow
3	Metal	Red
4	Glass	Green
5	Food	Black
6	Others	Sky blue

---

## **Occupational health and safety**

---

**Objectives:** At the end of this lesson you shall be able to

- **define safety**
- **state the goal of occupational health and safety**
- **explain need of occupational health and safety**
- **state the occupational hygiene**
- **explain occupational hazards**
- **brief the occupational disease.**

### **Safety**

Safety means freedom or protection from harm, danger, hazard, risk, accident, injury or damage.

### **Occupational health and safety**

- Occupational health and safety is concerned with protecting the safety, health and welfare of people engaged in work or employment.
- The goal is to provide a safe work environment and to prevent hazards.
- It may also protect co-workers, family members, employers, customers, suppliers, nearby communities, and other members of the public who are affected by the workplace environment.
- it involves interactions among many related areas, including occupational medicine, occupational (or industrial) hygiene, public health, and safety engineering, chemistry, and health physics.

### **Need of occupational health and safety**

- Health and safety of the employees is an important aspect of a company's smooth and successful functioning.
- It is a decisive factor in organizational effectiveness. It ensures an accident-free industrial environment.
- Proper attention to the safety and welfare of the employees can yield valuable returns.
- Improving employee morale
- Reducing absenteeism
- Enhancing productivity
- Minimizing potential of work-related injuries and illnesses
- Increasing the quality of manufactured products and / rendered services.

### **Occupational (Industrial) hygiene**

- Occupational hygiene is anticipation, recognition, evaluation and control of work place hazards (or) environmental factors (or) stresses
- This is arising in (or) from the workplace.
- Which may cause sickness, impaired health and

well being (or) significant discomfort and inefficiency among workers.

**Anticipation (Identification):** Methods of identification of possible hazards and their effects on health.

**Recognition (Acceptance):** Acceptance of ill-effects of the identified hazards

**Evaluation (Measurement & Assessment):** Measuring or calculating the hazard by Instruments, Air sampling and Analysis, comparison with standards and taking judgement whether measured or calculated hazard is more or less than the permissible standard.

**Control of workplace hazards:** Measures like Engineering and Administrative controls, medical examination use of Personal Protective Equipment (PPE) education, training and supervision.

### **Occupational hazards**

"Source or situation with a potential for harm in terms of injury or ill health, damage to property, damage to the workplace environment, or a combination of these"

Types of occupational health hazards

- Physical Hazards
- Chemical Hazards
- Biological Hazards
- Physiological Hazards
- Psychological Hazards
- Mechanical Hazards
- Electrical Hazards
- Ergonomic Hazards

#### **1 Physical hazards**

- Noise
- Heat and cold stress
- Vibration
- Radiation (ionising & Non-ionising )
- Illumination etc.,

#### **2 Chemical hazards**

- Inflammable

- Explosive
- Toxic
- Corrosive
- Radioactive

### 3 Biological hazards

- Bacteria
- Virus
- Fungi
- Plant pest
- Infection

### 4 Physiological

- Old age
- Sex
- Ill health
- Sickness
- Fatigue.

### 5 Psychological

- Wrong attitude
- Smoking
- Alcoholism
- Unskilled
- Poor discipline
  - absentism
  - disobedience
  - aggressive behaviour
- Accident proneness etc,

- Emotional disturbances
  - violence
  - bullying
  - sexual harassment

### 6 Mechanical

- Unguarded machinery
- No fencing
- No safety device
- No control device etc.,

### 7 Electrical

- No earthing
- Short circuit
- Current leakage
- Open wire
- No fuse or cut off device etc,

### 8 Ergonomic

- Poor manual handling technique
- Wrong layout of machinery
- Wrong design
- Poor housekeeping
- Awkward position
- Wrong tools etc,

#### Safety Slogan

**A safety rule breaker, is an accident maker**



**Safety Sign**

**Objectives:** At the end of this lesson you shall be able to

- list three kinds of road sign
- describe the marking on the road
- describe the various police traffic hand signal and light signal
- list the collision causes.

In older days road locomotive carrying a red flag by day and red lantern by night. Safety is the prime motive of every traffic.

Kinds of road signs

Mandatory

Cautionary and

Informatory

**Mandatory sign (Fig 1)**

Violation of mandatory sign can lead to penalties. Ex. Stop, give way limits, prohibited, no parking and compulsory sign.

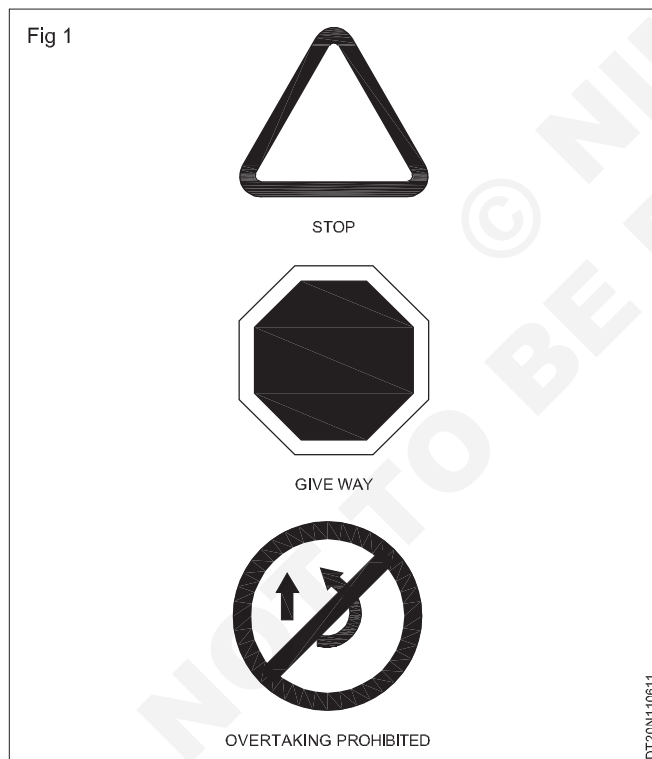

**Cautionary signs (Fig 2)**

Cautionary/ warning signs are especially safe. Do's and don'ts for pedestrians, cyclists, bus passengers and motorists.

**Information signs (Fig 3)**

Information signs are especially benefit to the passengers and two wheelers.

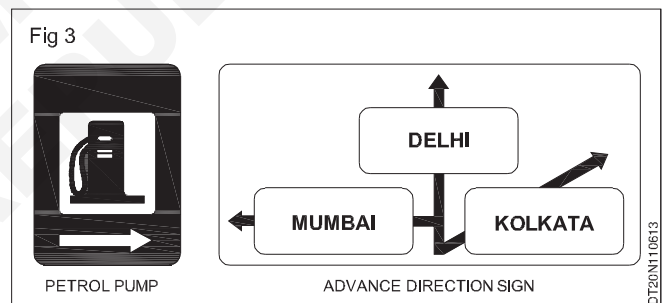

**Marking lines on road (Fig 4)**

- Marking lines are directing or warn to the moving vehicles, cyclist and pedestrians to follow the law.
- Single and short broken lines with middle of the road allow the vehicle to cross the dotted lines safely overtake whenever required.
- When moving vehicle approaching pedestrian crossing, be ready to slow down or stop to let people cross.
- Do not overtake in the vicinity of pedestrain crossing.

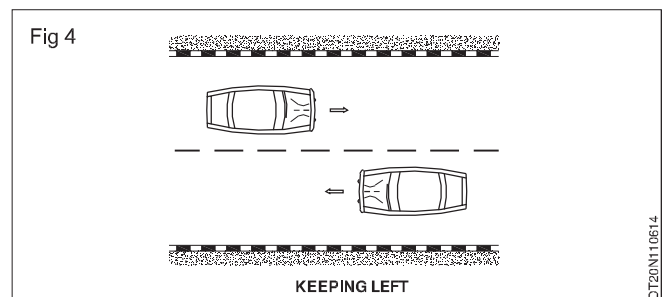

**Police signals**

To stop a vehicle approaching from behind. Fig 5(1)

To stop a vehicle coming from front. Fig 5(2)

To stop vehicles approaching simultaneously from front and behind. Fig 5(3)

To stop traffic approaching from left and wanting to turn right. Fig 5(4)

To stop traffic approaching from the right to allow traffic from left turn right. Fig 5(5)

To allow traffic coming from the right and turning right by stopping traffic approaching from the left. Fig 5(6)

Warning signal closing all traffic. Fig 5(7)

Beckoning on vehicles approaching from left. Fig 5(8)

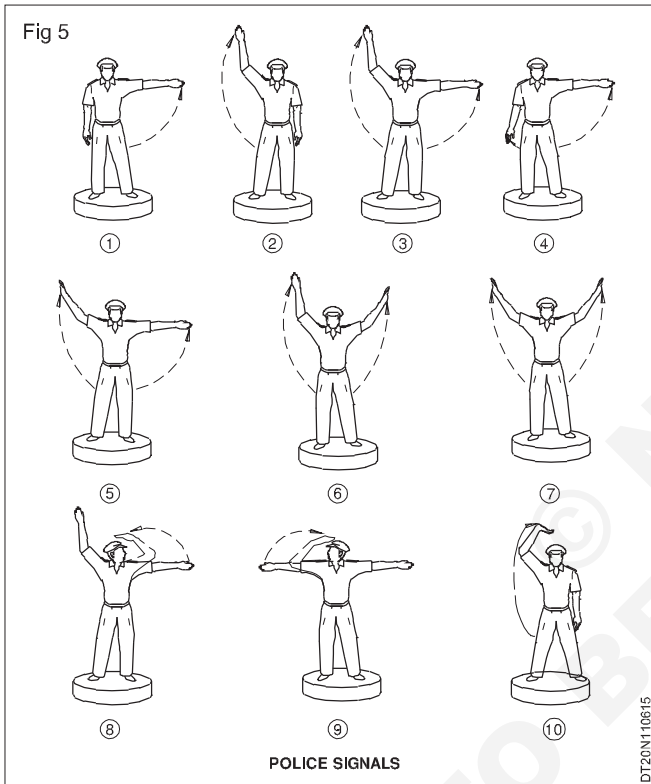

Beckoning on vehicles approaching from right. Fig 5(9)

Beckoning on vehicles from front. Fig 5(10)

**Traffic light signals**

Red means stop. Wait behind the stop line on the carriage way. Fig 6(1)

Red and amber also means stop. Do not pass through or start until green shows. Fig 6 (2)

Green means you may go on if the way is clear. Take special care if you mean to turn left or right and give way to pedestrians who are crossing. Fig 6(3)

Amber means stop at the stop line. you may only go on if the amber appears after you have crossed the stop line or so close to it that to pull up may not be possible. Fig 6(4)

Green arrow means that you may go in the direction shown by the arrow. You may do this whatever other lights may be showing. Fig 6(5)

Pedestrians - do not cross. Fig 6(6)

Pedestrians - cross now. Fig 6(7)

Flashing red means stop at the stop line and if the way is clear proceed with caution. Fig 6(8)

Flashing amber means proceed with caution. Fig 6(9)

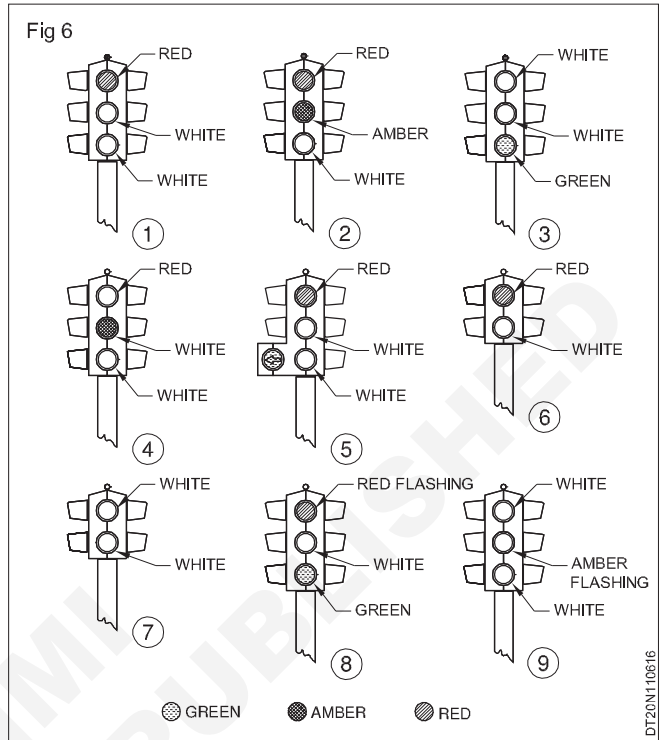

**Collision causes**

Three factors are responsible for collision

- Roads
- Vehicles and
- Drivers.

The fig 7 shows approximately proportionate causes of collision. In wrong attitudes such that avoid foolish acts at the wheel. Driving time is not play time. (Fig 8)

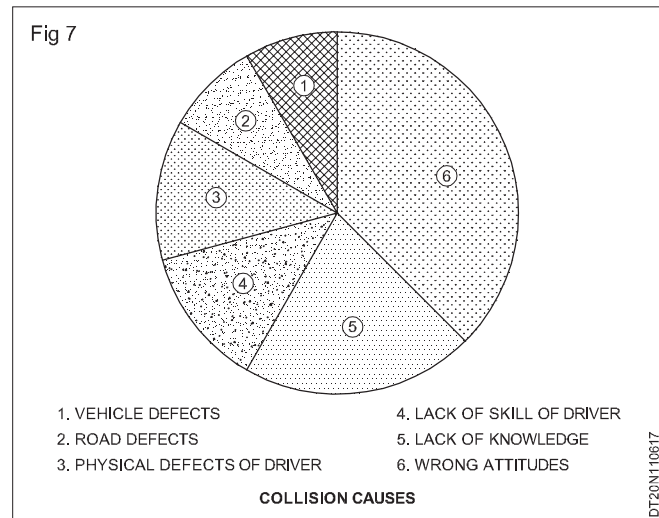

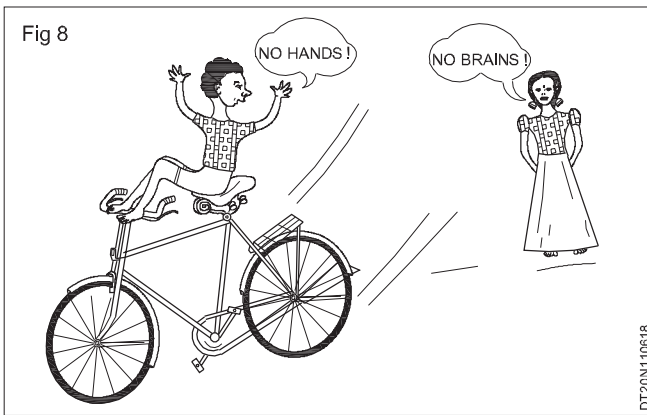

## Safety practice

**Objectives :** At the end of this lesson you shall be to

- state the responsibilities of employer and employees
- state the safety attitude and list the four basic categories of safety signs.

### Safety

The state of being safe, freedom from the occurrence or risk of injury, danger or loss.

### Responsibilities

Safety doesn't just happen - it has to be organised and achieved like the work-process of which it forms a part. The law states that both an employer and his employees have a responsibility in this behalf.

### Employer's responsibilities

The effort a firm puts into planning and organising work, training people, engaging skilled and competent workers, maintaining plant and equipment, and checking, inspecting and keeping records - all of this contributes to the safety in the workplace.

The employer will be responsible for the equipment provided, the working conditions, what the employees are asked to do, and the training given.

### Employee's responsibilities

You will be responsible for the way you use the equipment, how you do your job, the use you make of your training, and your general attitude to safety.

A great deal is done by employers and other people to make your working life safer; but always remember you are responsible for your own actions and the effect they have on others. You must not take that responsibility lightly.

### Rules and procedure at work

What you must do, by law is often included in the various rules and procedures laid down by your employer. They may be written down, but more often than not, are just the way a firm does things - you will learn these from other workers as you do your job. They may govern the issue and use of tools, protective clothing and equipment, reporting procedures, emergency drills, access to restricted areas, and many other matters. Such rules are essential and they contribute to the efficiency and safety of the job.

### Safety signs

As you go about your work on a construction site you will see a variety of signs and notices. Some of these will be familiar to you - a 'no smoking' sign for example; others you may not have seen before. It is up to you to learn what they mean - and to take notice of them. They warn of the possible danger, and must not be ignored.

Safety signs fall into four separate categories. These can be recognised by their shape and colour. Sometimes they may be just a symbol; other signs may include letters or figures and provide extra information such as the clearance height of an obstacle or the safe working load of a crane.

The four basic categories of signs are as follows:

- prohibition signs (Fig 1 & Fig 5)
- mandatory signs (Fig 2 & Fig 6)
- warning signs (Fig 3 & Fig 7)
- information signs (Fig 4)

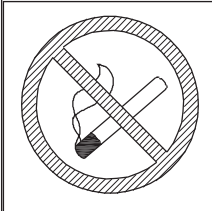
Prohibition signs	SHAPE	Circular.
Fig 1	COLOUR	Red border and cross bar. Black symbol on white background
	MEANING	Shows it must not be done.
	Example	No smoking

**Mandatory signs**

Fig 2



**SHAPE** Circular.

**COLOUR** White symbol on blue background

**MEANING** Shows what must be done

**Example** Wear hand protection

**Warning signs**

Fig 3

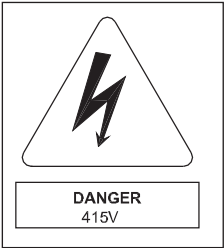

**SHAPE** Triangular

**COLOUR** Yellow background with black border and symbol.

**MEANING** Warns of hazard or danger.

**Example** Caution, risk of electric shock.

**Information signs**

Fig 4

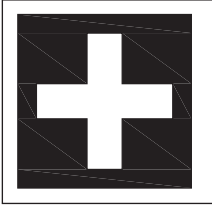

**SHAPE** Square or oblong.

**COLOUR** White symbols on green background.

**MEANING** Indicates or gives information of safety provision.

**Example** First aid point.

**Prohibition signs**

Fig 5

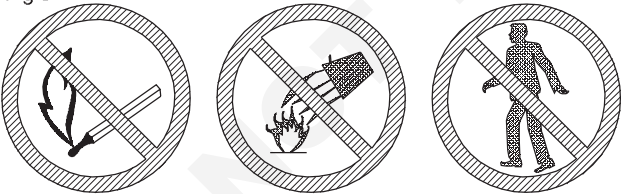

SMOKING AND NAKED FLAMES PROHIBITED

DO NOT EXTINGUISH WITH WATER

PEDESTRIANS PROHIBITED

**Mandatory signs**

Fig 6



WEAR HEAD PROTECTION

WEAR EYE PROTECTION

WEAR HEARING PROTECTION

WEAR FOOT PROTECTION

WEAR HAND PROTECTION

WEAR RESPIRATOR

WEAR SAFETY HARNESS/BELT

USE ADJUSTABLE GUARD

WASH HAND

MANDATORY SIGNS

**Warning signs**

Fig 7



RISK OF FIRE

RISK OF ELECTRIC SHOCK

TOXIC HAZARD

CORROSIVE SUBSTANCES

RISK OF IONIZING RADIATION

LASER BEAM

RISK OF EXPLOSION

OVERHEAD (FIXED) HAZARD

GENERAL WARNING RISK OF DANGER

OVERHEAD LOAD

FRAGILE ROOF

FORK LIFT TRUCK

WARNING SIGNS

**Question about your safety**

Do you know the general safety rules that cover your place of work?

Are you familiar with the safety laws that govern you particular job?

Do you know how to do your work without causing danger to yourself, your workmates and the general public?

Are the plant, machinery and tools that you use really safe? Do you know how to use them safely and keep them in a safe condition?

Do you wear all the right protective clothing, and have you been provided with all the necessary safety equipment?

Have you been given all the necessary safety information about the materials used?

Have you been given training and instruction to enable you to do your job safely?

Do you know who is responsible for safety at your place of work?

Do you know who are the appointed 'Safety Representatives'?

## Response to emergencies - Power failure, System failure & Fire

---

**Objectives:** At the end of this lesson you shall be able to

- state the reason of emergency power failure
  - state the cause of system failure
  - state the fire safety and immediate actions.
- 

1 If there is a power failure, start the emergency generator. This provides power to close the shutter, which is the first priority. The generator will also keep the UPSs and the cryogenic compressors running,

- Get a flash light.
- Look out for power transfer switch and switch over to normal power to emergency power by pressing the latch.
- Check the fuel valves open or not - Open the valves.
- Check to see that the main breaker switch ON the generator is in OFF position.
- Move the starter switch of the generator to run position. The engine will start at once.
- Allow few minutes to warm up the engine.
- Check all the gauges, pressure, temperature, voltage and frequency.
- Check the "AC line" and "Ready" green light on the front panel.

2 System failure

- If the bug or virus, invades the system. The system failure happens.
- Several varieties of bugs are there

1. Assassin bug
2. Lightning bug
3. Brain bug

For more details refer instruction manual for "System failure".

3 Fire failure

When fire alarm sounds in your buildings

1. Evacuate to outside immediately.
2. Never go back
3. Make way for fire fighters and their trucks to come
4. Never use an elevator
5. Do not panic

## Reporting emergency

---

**Objectives :** At the end of this lesson you shall be able to

- explain the report an emergency
  - report through emergency services.
- 

### Report an emergency

Reporting an emergency is one of those things that seems simple enough, until actually when put to use in emergency situations. A sense of shock prevail at the accident sites. Large crowd gather around only with inquisitive nature, but not to extend helping hands to the victims. This is common in road side injuries. No passer by would like to get involved to assist the victims. Hence first aid managements is often very difficult to attend to the injured persons. The first aiders need to adapt multitask strategy to control the crowd around, communicate to the rescue team, call ambulance etc, all to be done simultaneously. The mobile phones helps to a greater deal for such emergencies. Few guidelines are given below to approach the problems.

Assess the urgency of the situation. Before you report an emergency, make sure that the situation is genuinely urgent. Call for emergency services if you believe that

a situation is life-threatening or otherwise extremely disruptive.

- A fire - If you're reporting a fire, describe how the fire started and where exactly it is located. If someone has already been injured, missing, report that as well.
- A life - threatening medical emergency, explain how the incident occurred and what symptoms the person currently displays.

### Call emergency service

The emergency number varies - 100 for Police & Fire, 108 for Ambulance.

### Report your location

The first thing the emergency dispatcher will ask where you are located, so the emergency services can get there as quickly as possible. Give the exact street address, if you're not sure of the exact address, give approximate information.



**Different types of RPAS**

**Objectives:** At the end of this lesson you shall be able to

- differences in Different Types of RPAS
- characteristic of naming
- explore the history of the RPAS
- find out the types of RPA
- describe the Airframe
- find the basic components
- current/Future Uses of RPAS.

Fig 1

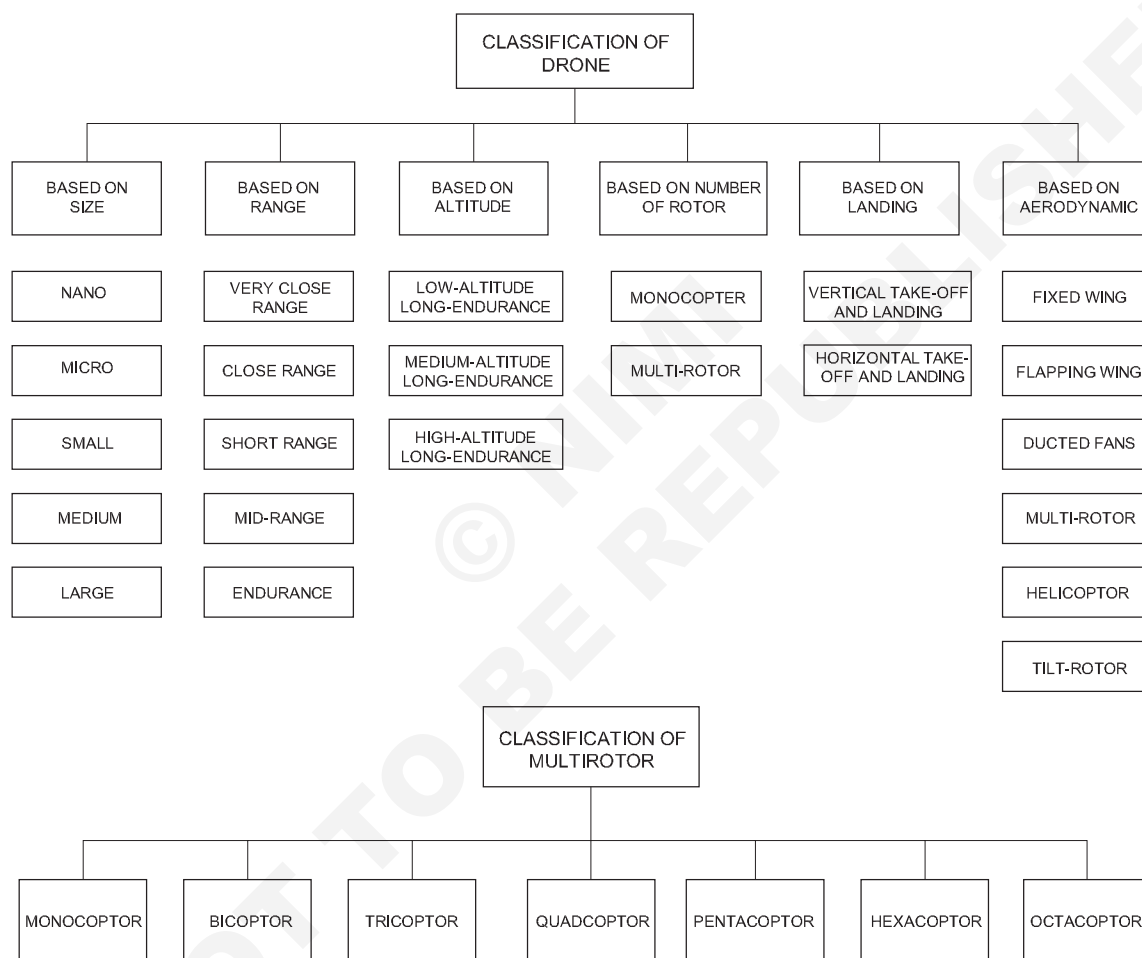

DT20N110711

These categories are specified by the DGCA Civil RPA in conjunction with MTOW (including payload) as shown below:

Nano	Less than or equal to 250grams
Micro	Greater than 250 grams and less than or equal to 2 kg
Small	Greater than 2 kg and less than or equal to 25 kg
Medium	Greater than 25 kg and less than or equal to 150kg
Large	Greater than 150kg

## Nomenclatures

AAI	Airports Authority of India	BVLOS	Beyond Visual Line of Sight
AD	Aerodrome	CAR	Civil Aviation Requirements
ADC	Air Defence Clearance	CASO	Civil Aviation Safety Officer
ADS-B	Automatic Dependent Surveillance - Broadcast	CB	Cumulonimbus
AERA	Airports Economic Regulatory Authority	CBEC	Central Board of Excise and Customs
AFRRO	Assistant Foreign Regional Registration Offices	CF	Carbon Fiber.
AFS	Aeronautical Fixed Services	CoG	Centre of Gravity
AGA	Aerodrome and Ground Aids	CISF	Central Industrial Security Force
AGL	Above Ground Level	C-MATZ	(Combined) Military Air Traffic Zone
AHRS	Attitude and Heading Reference System	CNS	Communication Navigation Surveillance
AIAA	Area of Intense Aerial Activity	CofA	Certificate of Airworthiness
AIC	Aeronautical Information Circular	COSCA	Commissioner of Security
AIP	Aeronautical Information Publication	CPWD	Central Public Works Department
AIS	Aeronautical Information Service	CTA	Control Area
AIU	Air Intelligence Unit	CTR	Control Zone
AMO	Aeronautical meteorological offices	D&A	Detect and Avoid.
AMS	Aeronautical Meteorological Stations	DADF	Department of Animal Husbandry, Dairying and Fisheries
AMSL	Above Mean Sea Level	DDO	District Development Officer
AOA	Angle of attack	DGCA	Directorate General of Civil Aviation
APHO	Airport Health Organization	DGFT	Directorate General of Foreign Trade
APIS	Advanced Passenger Information System	DGHS	Directorate General Health Services
ARC	Aviation Research Centre	DGPS	Differential Global Positioning System.
ARF	Almost ready to fly.	DIPP	Department of Industrial Policy & Promotion
ARP	Aerodrome Reference Point (published in AIP)	DME	Distance Measuring Equipment
ASC	Airport Security Committee	DPR	Detailed Project Report
ASDA	Accelerate-Stop Distance Available	DSM	Digital Spectrum Modulation
ASG	Assistant Secretary General	DVOR	Doppler VHF Omnidirectional Radio Range
ASP	Airport Security Program	ECA	Emergency Controlling Authority.
ASSN	Application Specific Sensor Node.	EDS	Explosives Detection Systems
ATC	Air Traffic Control	EEPROM	Electrically Erasable Programmable Read Only Memory
ATM	Air Traffic Management	ELEV	Elevator
ATR	Avions de Transport Regional	EMI	Electromagnetic Interference.
ATS	Air Traffic Service	ENR	En-route.
ATZ	Aerodrome Traffic Zone	ETA	Equipment Type Approval
AVSEC	Aviation Security	ETD	Explosives Trace Detection
AWIS	Aviation Weather Information Service	EVD	Explosives Vapour Detection
BCAS	Bureau of Civil Aviation Security	EVLOS	Extended visual line of sight.
BEC	Battery Elimination Circuit.	FDI	Foreign Direct Investment
BNF	Bind 'N' Fly	FHSS	Frequency Hopping Spread Spectrum
		FIR	Flight Information Region

FL	Flight level	MCA	Model Concession Agreement
FMV	Fair Market Value	MEF	Maximum elevation figure.
FOV	Field of View	MEMS	Microelectromechanical systems.
FPV	First Person View	MHA	Ministry of Home Affairs
FRRO	Foreign Regional Registration Office	MoCA	Ministry of Civil Aviation
FRTOL	Flight Radio Telephone Operator's License	MoD	Ministry of Defence
FTO	Flying Training Organization	MOHFW	Ministry of Health & Family Welfare
GCS	Ground Control System	MTOW	Maximum Take-off Weight
GDP	Gross Domestic Product	NBFC	Non-Banking Financial Company
GEN	General	NCASP	National Civil Aviation Security Programmer
GIS	Geographic Information System	NCT	National Capital Territory
GNSS	Global Navigation Satellite System	NOC	No Objection Certificate
GOI	Government of India	NOTAM	Notice to Airmen
GPS	Global Positioning System	NPNT	No Permission-No Takeoff
HHMD	Hand-held Metal Detectors	NQE	National Qualified Entity.
HIRTA	High intensity radio transmission area	NTRO	National Technical Research Organization
HL	Home Lock	OAS	Obstacle Avoidance System
IAF	Indian Air Force	OAT	Outside Air Temperature
IAL	Instrument Activity List	OM	Operations Manual
ICAO	International Civil Aviation Organization	OSC	Operational Safety Case
IFL	Interest Free Loan	OSD	On Screen Display.
IFR	Instrument Flight Rules	PDB	Power Distribution Board
IHR	International Health Regulations	PfCO	Permission for Commercial Operation.
IMD	Indian Meteorological Department	PROP	Propeller
IMU	The Inertial Measurement Unit	PPL	Private Pilot License
INS	The Inertial Navigation System.	PPP	Public Private Partnership
IOC	Intelligent Orientation Control	PWD	Public Works Department
IPC	Indian Penal Code	RF-ID	Radio Frequency Identification
IPPC	International Plant Protection Convention	RNFC	Route Navigation Facilities Charges
ISA	International Standard Atmosphere	RPA	Remotely Piloted Aircraft
ISD	International Subscriber Dialling	RPAS	Remotely Piloted Aircraft System(s)
IST	Indian Standard Time	RPM	Revolutions Per Minute.
JCC	Joint Co-ordination Committee	RPS	Remote Pilot Station(s)
JVC	Joint Venture Company	RSSI	Received Signal Strength Indicator.
LAANC system:	Low Altitude Authorization and Notification Capability system.	RTF	Ready to Fly
LAN	Local Area Network	RtH	Return to Home.
LiPO	Lithium Polymer Battery.	SARPs	Standards and Recommended Practices
LOS	Line of Sight.	SIM	Subscriber Identity Module
mAh	milli Amp Hours.	SPV	Special Purpose Vehicle
MAV	Micro Air Vehicle	SRA	Slum Rehabilitation Act
		STD	Subscriber Trunk Dialling
		SUA	Small Unmanned Aircraft



and also for spraying pesticides in agricultural fields, drones are not only for two-application. There are many such applications which are unknown to all till now. They can be solved with the help of a drone.

The technology of our world is increasing day by day, but drone applications have made our busy life easier.

UAV handling for combat surveillance, weather forecasting, insect spraying and more.

Mostly the drone prototypes are used for military, defense organization. Apart from this, there are many other beneficial things. Real in the future. UAV

technology has become commercial in order to pay high employment opportunities for unemployment.

Airframe, configurations, basic components.

### Airframe

The airframe is the supportive basic part for all mounted components. The Frame depends on the overall design & configuration part of the drone. This will be the first decision to design a drone.

Example: - the fuselage, undercarriage, empennage and wings, and excludes the propulsion system.

Fig 2

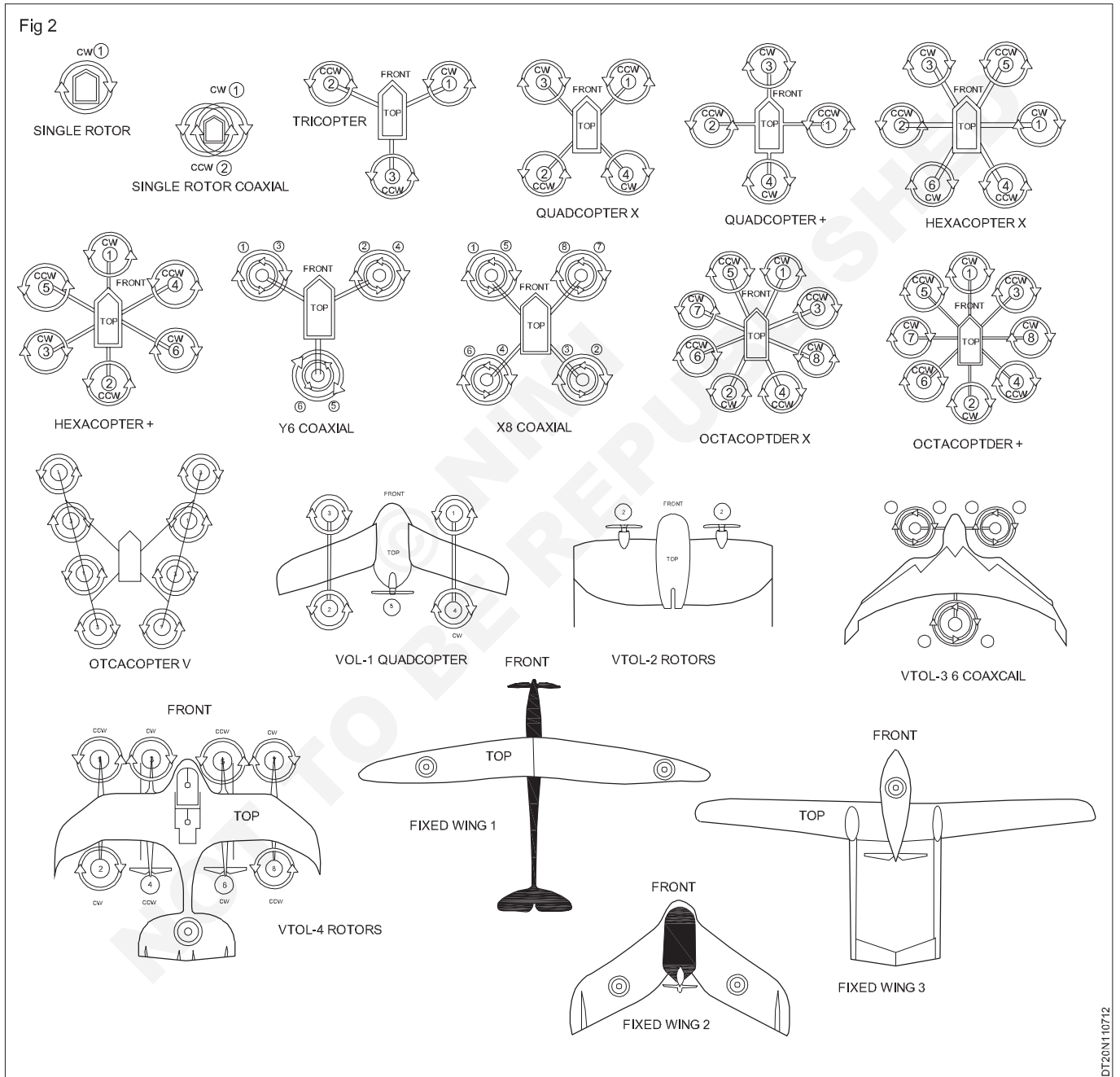

### Configuration

The different frame configuration

Basic components of Drone

The main parts are:

- 1 Motors (BLDC)
- 2 Propellers
- 3 ESC'S
- 4 Flight controller

- 5 Transmitter box and Receiver
- 6 Battery
- 7 Frame
- 8 Power Distribution Board
- 9 GPS
- 10 Sensors
- 11 Landing gears

### Brushless Motors

The motors used in drones are brushless. These motors are familiar for smooth operation by producing the large amount of torque of a Synchronous Motor. Permanent magnets rotate around a fixed armature position.

### Propellers

The propellers of the drone help to lift it. Here the rotational motion changed to another form called the anti-thrust force to keep it upwards against the force of gravity. Propellers works on Two Principles.

- 1 Bernoulli's principle
- 2 Newton's 3rd law of motion

### ESC'S

The electronic speed controller (controlling electronic device) is used to maintain the speed control of the electric motor & it executes the dynamic break based on the RC models; they are powered electrically. In the case of brushless motors, they generated a low voltage source of 3-phase electrical power energy to drive the motor. The ESC throttle is a separate control unit for the receiving channel.

### Flight controller

The flight controller is used to direct the way for hovering. It looks like a small electronic circuit board. Mostly the FCB should have multiple features for flight control.

The command of the pilot is multiple features for flight controlling installed in FC. it directs the motors accordingly. "FC is the brain of drone".

### Transmitter Box and Receiver

The transmitter is an electronic device that generates radio frequency by alternating the current. The antenna is elevated by alternating current. The transmitter antenna emits the radio waves to receiver. At where it is transferred to a useful information. The channels differ for different control modes it depends on the type of transmitter setting if we use a four-channel radio transmitter, it can perform to control four- modes instead of controlling more etc.

### Receiver

An electronic device, which detects the radio waves & makes them into useful information in a reliable form.

Minimum it requires 4 flight control channel units. Both TX & Rx be on the same channel for better flight communication.

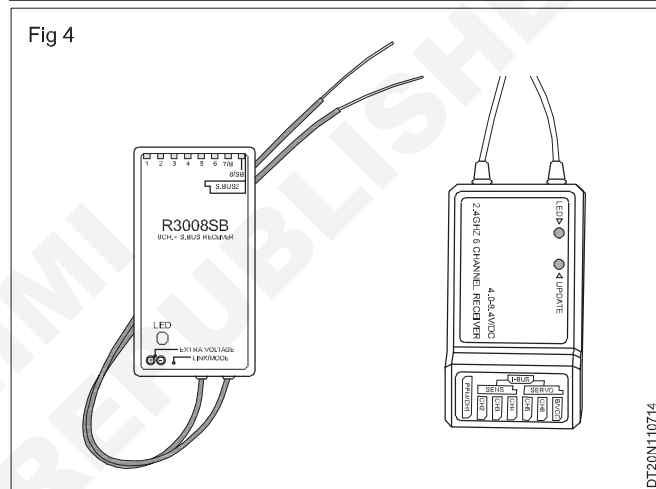
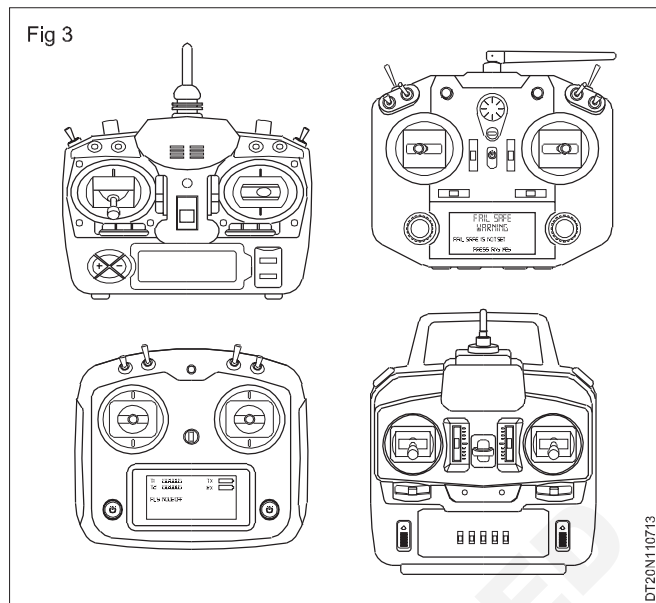

### Battery

Lithium polymer batteries are used in custom drones. These are highly weighted. The energy which can be stored at a once, that can be calculated in terms of "mAH". the flight time doesn't depend on the size of the battery. But it depends on the amount of energy stored in battery. After certain flight modulation, the agility of the drone decreased.

### Frame

The frame is the supportive basic part for all mounted components. Frame depends on the overall design & configuration part of the drone.

### Power Distribution Board

PDB distributes the power for all components of the multirotor. The components are connected on the board with wires and are soldered perfectly. Board confines the circuitry portion for proper arrangement of wire segments.

### GPS Module

GPS module helps the drone to navigate longer distances & records the complete info of particular locations on land. GPS navigations track the distance of flight areas. GPS helps the drone to return back home safely.

## Sensor

A sensor is a device, which works together with electronic boards. The word “sensor” defines to detect the physical change that happens in the environment & the output is informed to other connecting electronic gadgets to take quick actions.

## Landing Gear

Design is mostly based upon a helicopter landing gear module. The landing place will be widely opened & clearer, which makes the drone perform a safe landing.

## Balanced Battery Charger

A smart charger uses smart technologies for charging and balance several cells which are located inside the battery.

## Current/ future uses of RPAS.

### Military drones:

Military drones are used over a decade of time. UAV used for surveillance, monitoring, commanding target on enemies. However, for this technology Armed forces showing much more interest and they are investing develop the UA. This is building a greater opportunity for drone manufacturing.

## Agriculture

Agriculture is an endless process which is made by farmers. The cost expenses for raising up a crop is expendable. This issue will be a burden to spend more money to Agri-Field. To avoid such difficulties, drone providing so many solutions. We all risen-up by learning that (honey-bees) are used for pollinating flower drones also been used to pollinate it will be proved one day, it can compensate the bee declining population. The productivity of field increases. The pest spraying be done with a drone. Drone access the data & provide the information of the field. UAV's have thermal- imaging cameras to detect the diseased parts of the plant for Ex: - raptor maps and Agriculture analytics start up using drone to a better forecast of field. They assisting farmers for potential harvest. Airborne seed dispersal is also possible by drone. Abundant robotics also evolving a solution for autonomously picking.



## Agriculture Drone useful:

- 1 Soil Analysis:
- 2 Spraying and sowing:
- 3 Plant Count:
- 4 Health Analysis (Fruits, leaves and flowers)
- 5 Data – Analyzation
- 6 High- efficient work
- 7 Eco- friendly
- 8 Irrigation
- 9 3-D mapping (Land Surveying)

## Mining

Drones are used to capture the volumetric data on stockpiles with unique cameras & able to survey Mining operations from the air, which reduces the surveyors on the ground. Mining also being held by autonomous UGV's.

On site drone solution for mining companies to operate work like surveying, security enhancing, measuring materials. The drones are totally autonomous, which can store the data on cloud platform services.

## Mapping

So many lands are unavailable to mankind. To take 3D – Mapping. Images, which is easier to find the lands & makes them usable. This can be an organization to make every one available. Finding the location made easier by drone.

## Drone Racing & Gaming Sports

Like video gaming, drone gaming be a trend of today. Aerial racing fills us with happiness because no incidents happened in oriented space. Being a hobby to everyone. It creates recreational thoughts in young minds. This aerial flight exercise creates un-condition practices to all. Precautions are mandatory who are participating in drone racing.

## Security

Security is most important high alert systems enabling for comprehensive surveillances in industries & residential properties. Even through security is maintain but suspicious activities held at some place. Drone deploys with live streaming then immediately alarm triggered, make the security teams alert and footages can be captured.

## Solar Inspection

Now a day's solar project has been developed in many places, it requires solar inspections. To avoid manual work, presently drones are taken part for doing solar inspection and it sends data to Maintenance Department for analyse.

## Surveillance & Aerial Monitoring

Drone are used as spy with all certifications. We can avoid risk, issues & security some problems surveillances done by drone are given below.

- 1 Security
- 2 Traffic monitoring
- 3 Board Security

**Drones based on aerial platforms and construction materials.**

**Objectives:** At the end of this lesson you shall be able to

- Define aerial platform
- Explore the type of drone based on aerial platform
- Explore the type of drone based on body material.

**Understanding Aerial platforms**

**Types of Drones According to Aerial Platforms**

Based on the different aerial platform, there are following four major types of UAV (drone)

- 1 Single Rotor Drone (SRD)
- 2 Multi Rotor Drone (MRD)
- 3 Fixed Wing Drone (FWD)
- 4 Hybrid (Combination of Fixed Wing and Multirotor)

**Single-Rotor**

A helicopter, single-rotor drone in which horizontally-spinning rotors provide lift and thrust. Single rotor drones are more powerful than multi-rotor drones.

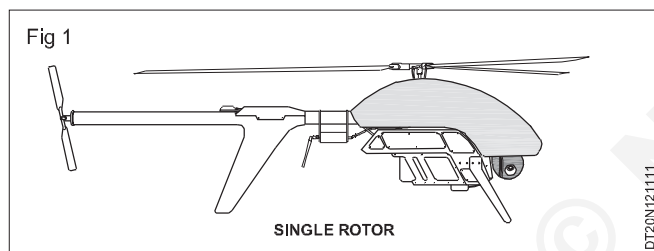

**Multi-Rotor**

The most famous types of drones that hobbyists and professionals use are multirotor drones. Popular multirotor applications are aerial photography, video surveillance, and survey. based on the number of rotors in the multirotor they have on the aerial platform:

- Tricopters
- Quadcopters
- Hexacopters
- Octocopters

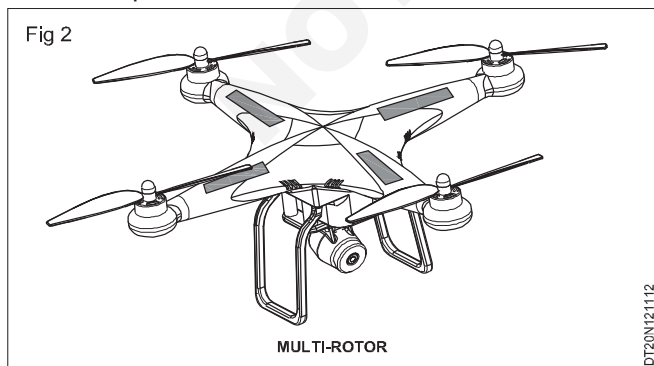

**Fixed-Wing**

Fixed-wing drones is an aircraft special type of drone which works similarly to commercial aircraft. It consists

of a wing that has air-foil shapes generating liftforce caused drone moves into upwards direction and by an internal combustion engine or electric motor generated thrust force produced by drone moves into a forward direction. Fixed-wing Drone can carry various “payloads”, data-link equipment and has the “longest range” over any of the other types of drones. Fixed-wing drones required a runway during “landing or take-off”.

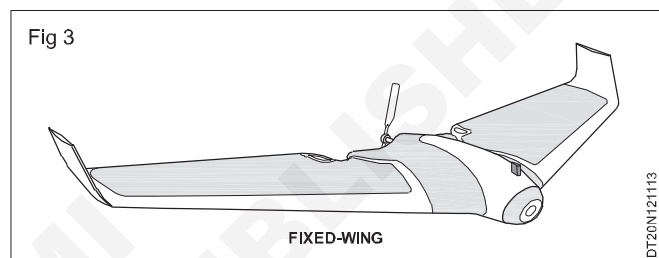

**Fixed-Wing Hybrid**

This type of fixed-wing aircraft has Vertical Take-off and Landing (VTOL) technology. This type of drone is a combination of the multirotor and fixed-wing due to which it resolved vertically take-off and transition to horizontal flight and make the drone capable to hover. In this drone type, designs of the “rotor” or the wings with propellers pointing “upwards for take-off, and horizontally” for forward flight.

**Types of drones based on body material**

- 1 **Plastic:** Plastic is light weight, cost effective, show some issues on balance causes sound formation.

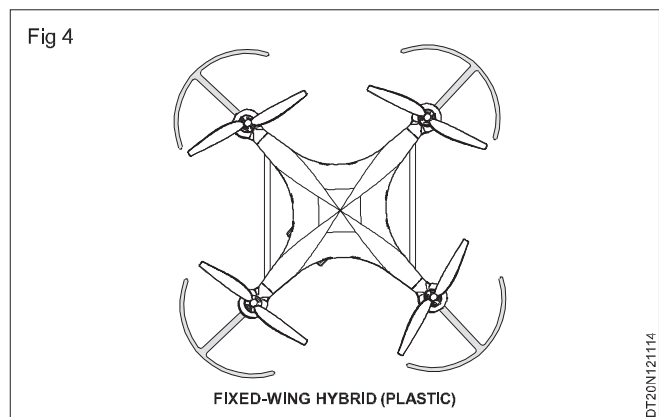

- 2 **Carbon Fiber:** This fiber is Lighter in weight, balancing is greater to handle, high strength and gives durability but cost is very high. Carbon fiber propeller produces lower thrust as compare to plastic.



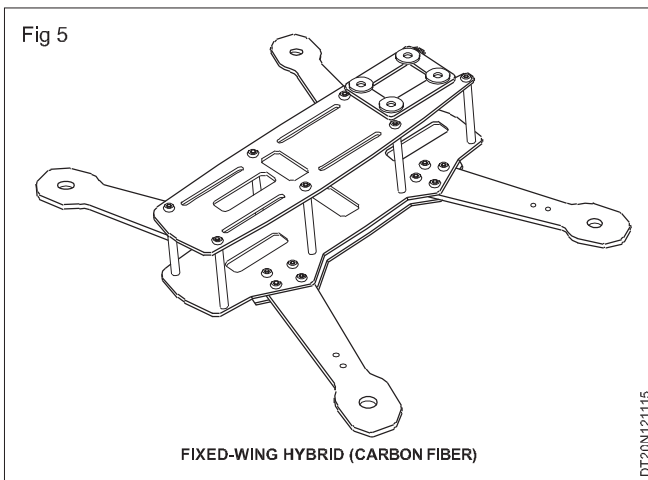

3 **Wood:** Wooden propellers were used rarely. All sorts of wood have been used to make propellers, but yellow birch, sugar maple, black cherry, and black walnut are the most pleasing.

4 **Aluminum:** Aluminum drone frame is lightweight and easy to carry, convenient for storage and carrying.

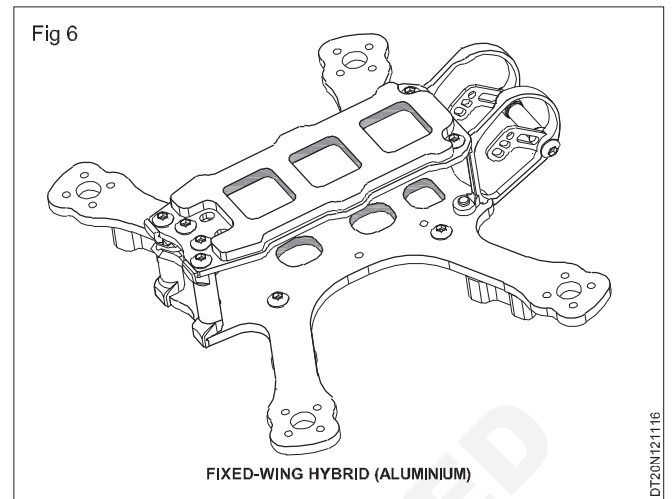

## Aerodynamic - Flight law and principle.

**Objectives:** At the end of this lesson you shall be able to

- define aerodynamics
- explore the history of the Hawaiian RPAS
- find out the amount of RPA
- define Bernoulli's principle
- describe the four forces of flight
- describe the three routes of flight
- explain how they apply to RPA flying.

### Aerodynamics

Aerodynamics is the branch of physics that deals with the motion of air or gaseous fluids and about the forces acting on bodies while passing through fluid or flow of air.

### Fluid

A fluid is any substance that flows or deforms under applied shear stress and have the tendency to flow

### History of Flight

#### A Brief History of Flight

His Flying Machine, a design for an ornithopter that was never built but whose concept was later used to create the helicopter.(Fig 1)

- In 1783 - A first manned flight was done by the Montgolfier brother who was created the first hot air balloon.(Fig 2)
- On December 17, 1903, wright brothers flew the Flyer 120 feet in 12 seconds.(Fig 3)

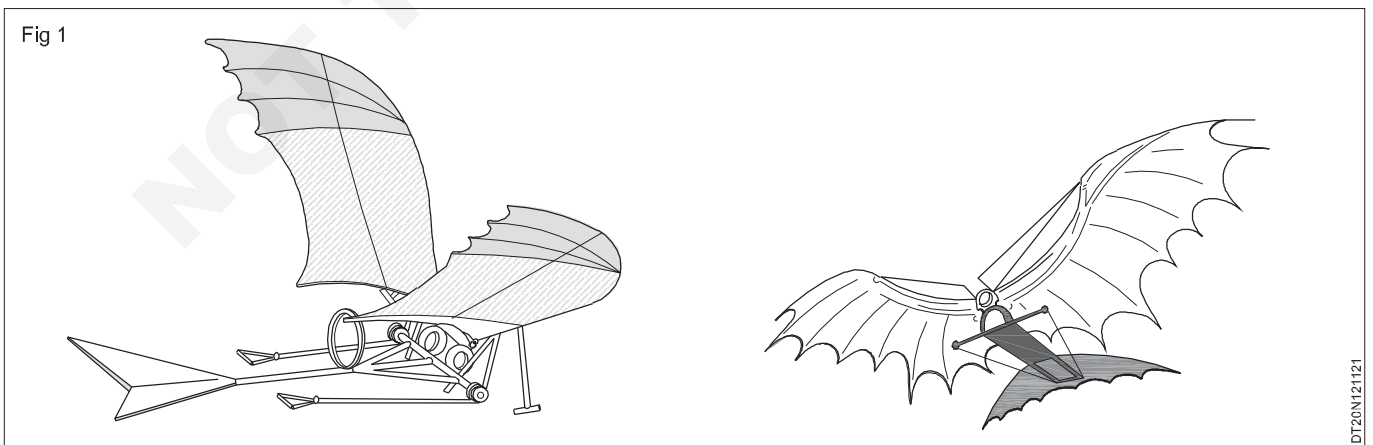
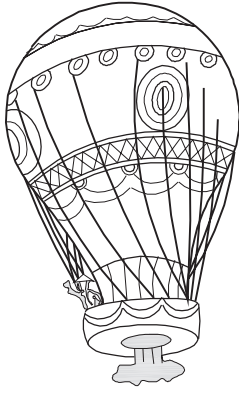
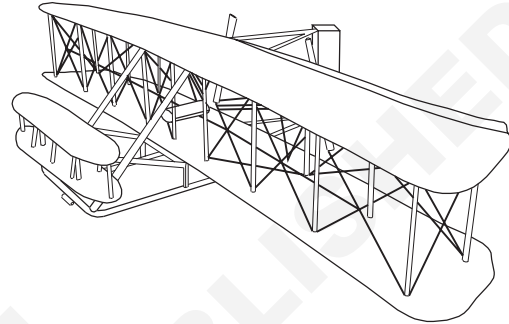
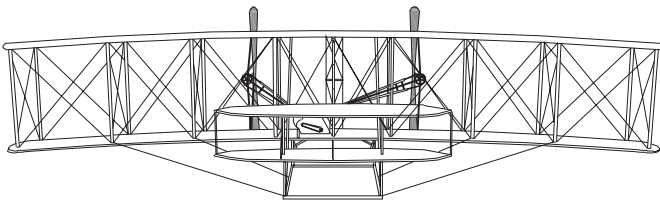

Fig 2



DT20N121122

Fig 3



DT20N121123

- 1927-Charles A. Lindbergh comes first nonstop trans – Atlantic flight.
- 1939- First Modern Airliner, Boeing 247 files.

**Newton’s Laws of Motion (Fig 1)**

**First Law of Motion: Inertia**

A body at “rest or uniform motion” will remain to be at rest or uniform motion until and unless a net external force act on it.

**Second Law of Motion: Force**

The “second law of motion” states that the applied net force is directly proportional to the rate of change of momentum of a body.

$$F = ma$$

**Third Law of Motion: Action & Reaction**

The “third law of motion” states that for every action it shows an “equal and opposite reaction”.

Fig 1

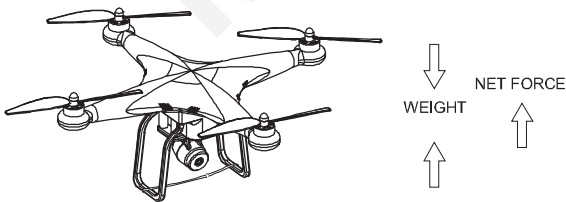

DT20N121131

**Bernoulli’s Principle (Fig 2)**

Bernoulli’s principle plays an important role in understanding air-flow to understand the principle behind drone lift in the air.

Bernoulli’s principle states that a decrease in the static pressure or a decrease in the potential energy of the fluid increases the velocity of the fluid.

**Example:** The velocity over the upper surface of the aircraft wing is higher than the pressure and at the bottom surface pressure is higher than the velocity of air.

Fig 2

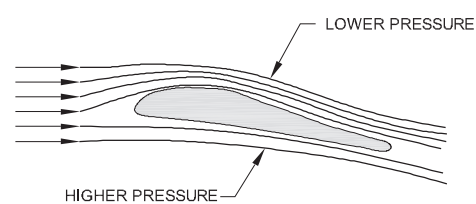

DT20N121132

**The Equation of Bernoulli’s Principle (Fig 3)**

Fig 3

ENERGY PER UNIT VOLUME BEFORE = ENERGY PER UNIT VOLUME AFTER

$$P_1 + \frac{1}{2} \rho v_1^2 + \rho gh_1 = P_2 + \frac{1}{2} \rho v_2^2 + \rho gh_2$$



THE OFTEN CITED EXAMPLE OF THE BERNOULLI EQUATION OR “BERNOULLI EFFECT” IS THE REDUCTION IN PRESSURE WHICH OCCURS WHEN THE FLUID SPEED INCREASES.

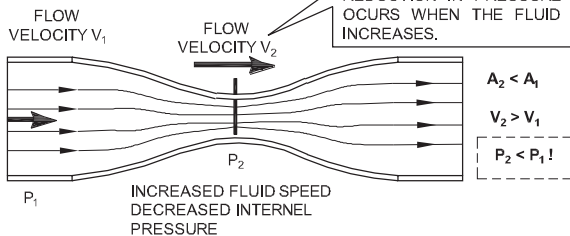

DT20N121133

## Four forces of Flight (Fig 4)

Four main forces stabilize the flight. For any object to fly, it must balance these four forces (see fig) Forces are:

- 1 Lift
- 2 Drag
- 3 Weight
- 4 Thrust.

The lifting force is used to lift upwards, drag pushes backward, thrust forwards, and weight pushes downwards.

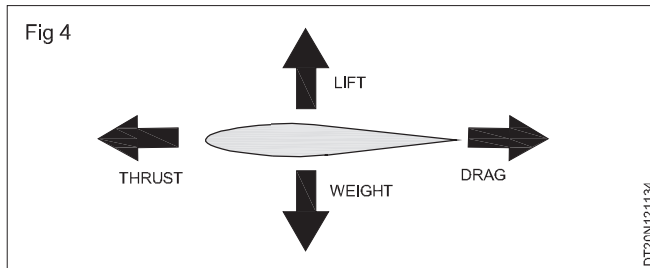

## Three Axes of Flight

To stabilize the drone, the rotation of its three axes has to be balanced. Three axes of flight are an imaginary line: “lateral axis, longitudinal axis and vertical axis” (see fig.) on which it can moves Left and Right, Up and Down, Forwards and Backwards.

### The Lateral Axis (Pitch)

The lateral axis lies from “wing tip to wing tip”. The drone pitches around this imaginary line (axis).

### The Longitudinal Axis (Roll)

The longitudinal axis lies from the “nose of the aircraft” to the tail. This is the imaginary line (axis) around which the drone rolls.

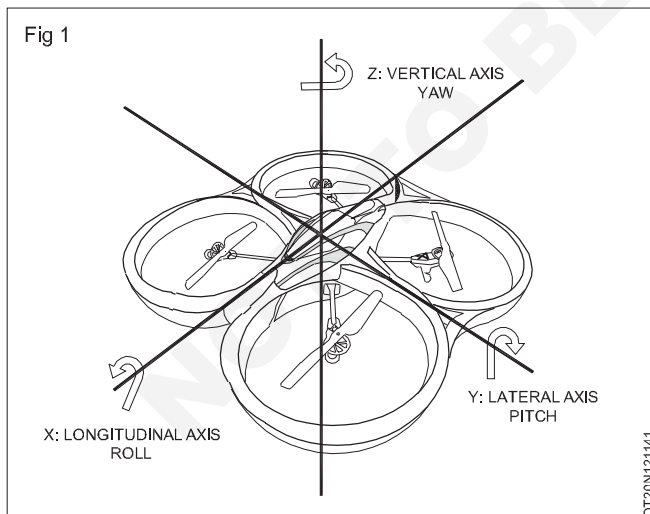

### The Vertical Axis (Yaw)

The vertical axis is slightly dissimilar to the other axis, running vertically through the center of the drone.

The air velocity decreases and pressure increase at the bottom side of Drone propeller/aircraft wing.

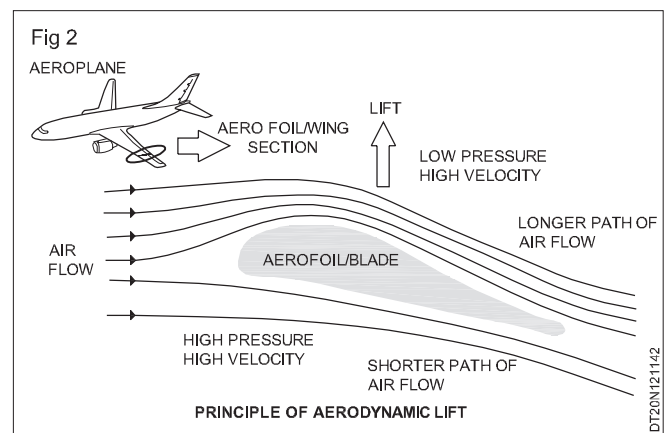

## Newton's Laws of Motion

### Newton's First Law: Inertia

The motion of a drone when a drone pilot changes the throttle setting of a motor.

### Newton's Second Law: Force

An drone motion resulting from aerodynamic forces, aircraft weight, and thrust.

### Newton's Third Law: Action & Reaction

The motion of lift from an airfoil, the air is deflected downward

by the airfoil's action, and in reaction, the wing/propeller is pushed upward.

## Apply Four Forces of Flight on drone.

### Weight

- Due to the mass of the drone, the body mass force always acts in the direction of gravity
- Higher the weight of the drone, more power is required to lift and move the drone.

### Weight of drone = mass of drone × acceleration due to gravity

### Drag

- The force acting on the drone in the opposite direction of motion due to air resistance is called drag
- This may be because of pressure difference and viscosity of air
- To reduce the drag, the aerodynamic shape of the drone is selected

### Thrust

- The force acting on the drone in the direction of motion is called thrust. However, for drone dynamics, it is normal to the rotor plane.
- During hovering, the thrust is purely vertical. If thrust is inclined then the drone will tilt forward or backward.
- This force is essential to move the drone in the desired direction at equal speed to get desired motion, two propellers have been given high speed.



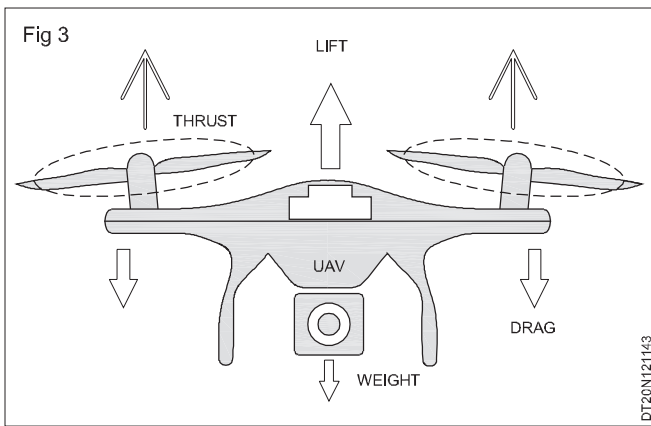

## Introduction to 3D printer and its designing

**Objectives :** At the end of this lesson you shall be able to

- state the 3D printer
- determine 3D printer software
- Illustrate the 3D printer material.

### Introduction to 3D printer

3D printing is a process of creating three dimensional solid objects with the computer-aided design (CAD) models. In 3D printing a part is create by adding material layer by layer until final product is created. 3D printing can be used to create prototype, create replacement parts etc

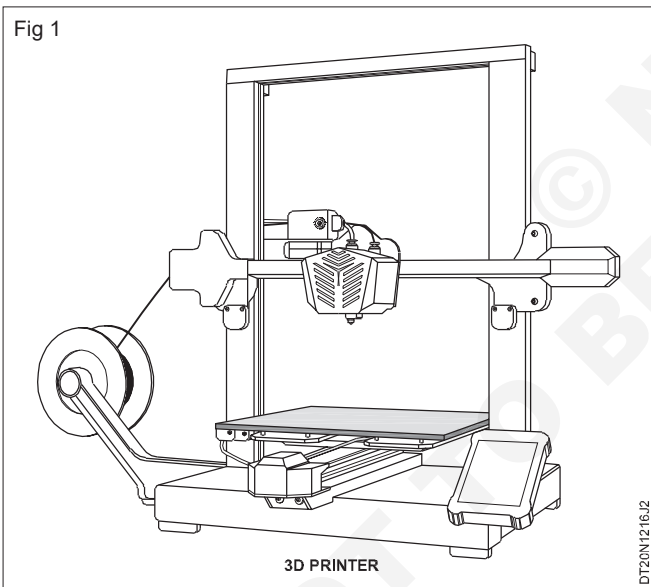

### software for designing various types of propellers

There is various software are available to design propeller

#### 1 software to create 3D Model

These 3D models can be created using a computer-aided design (CAD) software package such as

- Fusion 360
- Autodesk Inventor
- SolidWorks
- Catia

#### Fusion 360

Fusion 360 software mostly use for designing flat surface objects. But more complex objects cannot be designed using this software and it is one of the low-cost 3D-model designing software

#### Solid Works VS Autodesk Inventor

This two software, use to design complex 3D models

#### Catia

Catia is provides number of useful features. It is the most compatible 3D model designing software and creating bug-free STL files is most worthy features.

Fig 2

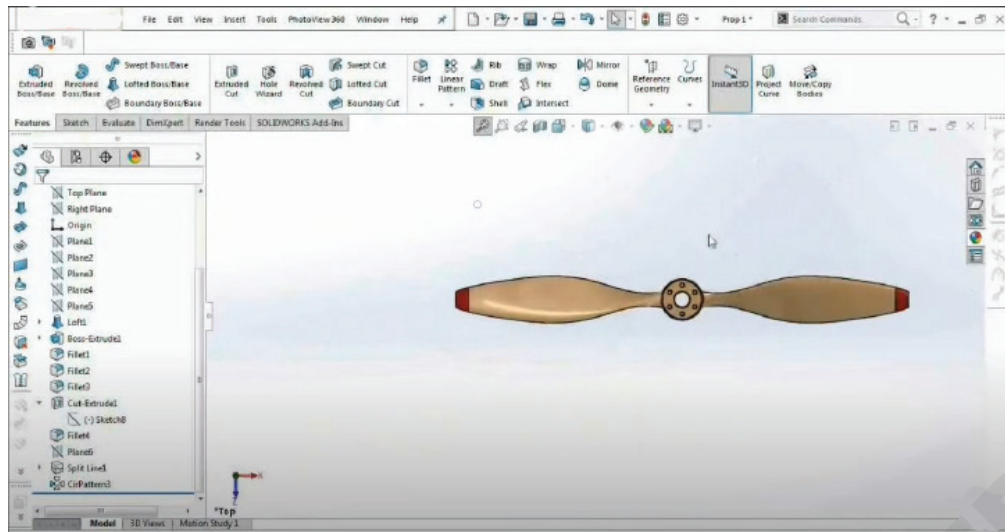

Select 3D printer material from Table

3D Printing Materials Data				
	Alumide	PA 2200 (Nylon)	UV curable acrylic plastic	ABS
3D printing technology	SLS	SLS	MJM	FDM
accuracy	±0.15mm	±0.15mm	±0.025mm-0.05mm	— <sup>a</sup>
min. wall thickness	0.8mm	0.7mm	0.3mm	— <sup>a</sup>
density	1.36g/cm <sup>3</sup> <sup>b</sup> 0.67g/cm <sup>3</sup> <sup>c</sup>	1.93g/cm <sup>3</sup> <sup>b</sup> 0.45g/cm <sup>3</sup> <sup>c</sup>	1.02g/cm <sup>3</sup>	1.05g/cm <sup>3</sup>
tensile modulus	3800MPa	1700MPa	1108MPa	1627MPa
tensile strength	48MPa	48MPa	26.2MPa	22MPa
flexural modulus	3600MPa	1500MPa	n/d	1834MPa
flexural strength	72MPa	58MPa	26.6MPa	41MPa
elongation at break	4%	24%	9%	6%
shore D - hardness	76	75	n/d	n/d
thermal properties	172-180°C (melting point) 177°C (heat deflection temp. at 0.45MPa)	172-180°C (melting point)	45°C(heat distortion temp. at 0.45MPa) 80°C (heat softening temp.)	190-240°C (melting point) 90°C (heat deflection temp. at 0.45MPa)
recycling	non recyclable	recyclable	most recyclable	recyclable

**Illustrate soldering and its componets.**

- Objectives:** At the end of this lesson you shall be able to
- study the soldering and desoldering station and their specification
  - explain the purpose of solder and flux and their types
  - describe the soldering technique
  - describe the features of soldering iron
  - explain desoldering and desoldering tools.

**Soldering and Desoldering Stations**

A typical competitive soldering station with ESD safe by design will comprise of hot air station soldering, LED double digital display. This kind of stations will come with PID controlled closed loop of sensor. The desolder station can give rapid heating, precise and stable temperature, suitable for soldering and de-soldering surface mounted. Such as QFPM PLCC, SOP, BGA etc package of ICs. Hot air station and intelligent cooling system, adopts imported heating wire, for a long life. There are normally light portable handle and suitable for mounting and reworking SMD component by hand for a long time.

**Typical specifications of a Solder and Desolder stations :**

**Hot Soldering Station :**

Air Flow	:	0.16 - 1.2 Nm3/h
Pump Consumption	:	45W
Temp. Control	:	150-450°C
Heater	:	250W Metal
Rated Voltage	:	110V/220V 50/60Hz AC
Power Consumption	:	270W
Air Pump	:	Membranous
<b>Solder Equipment</b>	:	
Power Consumption	:	60W
Output Voltage	:	24V AC
Temp. Control	:	200-480
Ground Resistance	:	20 ohms
Heater	:	Ceramic Heating Element

A typical station look like as shown in Fig 1

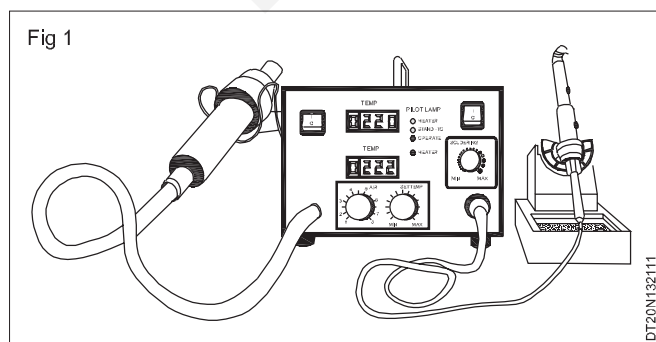

**Soldering**

Soldering is a process of connecting any two metallic surfaces such as copper, brass and alloys of these metals. Some types of solder joints are shown in Fig 2

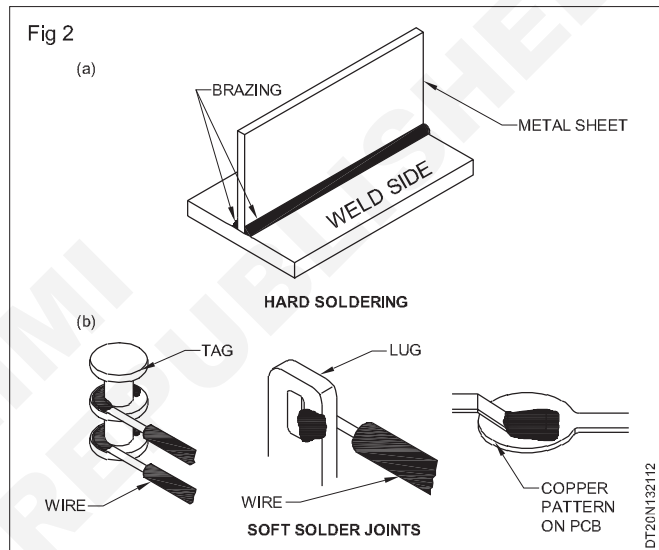

There are two types of soldering,

- 1 **Hard soldering or brazing** used for joining large metal parts as shown in Fig 1a.
- 2 **Soft soldering** used to form good electrical joints/connections between electrical/electronic parts as shown in Fig 1b.

Soft soldering is used extensively for electronic circuit wiring. In this lesson only soft soldering is discussed. Hard soldering or brazing is out of scope of this lesson.

**From now on in this book, soldering means soft soldering.**

**Need for soldering**

Requirements of an electrical joint

- 1 The electrical joint must provide ideally zero resistance or at least a very low resistance path, for the flow of current.
- 2 The electrical joint made should be strong enough to withstand vibrations, physical shock, bumps etc, without causing any deterioration to the quality and strength of the joint.

3 The electrical joint should be able to withstand corrosion and oxidation due to adverse atmospheric conditions.

All the above requirements of an electrical joint can be achieved by making a solder joint.

## Solder

In a soldered joint, the solder is a mixture of metals, generally TIN and LEAD. It is made to melt at a certain temperature. It acts as a filler between the parts of the connection/joint to form a continuous, low resistance metallic path for conduction of electricity.

In soldering, as the metal surface is wetted (free flow of liquid solder over a surface) by the solder, a complex chemical reaction, bonds the solder to the metal surface.

The tin content of the solder diffuses with the metal surface to form a layer of a completely new alloy. The alloy so formed will have the same structure as the constituent metals and retain their metallic properties and strength.

## Soldering and soldering irons

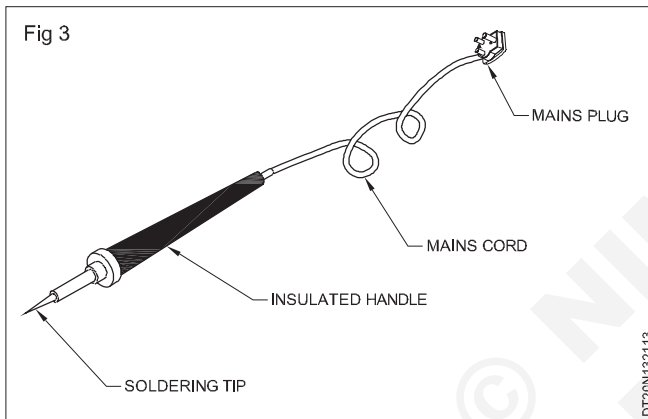

While soldering, the solder is made to melt between the metallic surfaces of the joint, using a soldering iron, as shown in Fig 3. A **soldering iron** is an instrument used to produce the required heat to carry out soldering.

Soldering irons of different wattage ratings starting from 10 watts to more than 150 watts are available commercially. Depending on the type, size and heat sensitivity of the components being soldered, the most suitable wattage soldering iron should be chosen. Most of these soldering iron work on 240V, 50Hz AC mains supply. There are special type irons which work on dc supply also. For soldering delicate components, soldering irons with temperature controlling facility are used. These are known as soldering stations.

## Soldering iron tips

Soldering irons are designed to take, a variety of tip sizes and shapes as shown in Fig 4. The choice of the iron and the tip to use depends on, the nature of the joint to be soldered. A proper selection of the soldering iron and tip is important for obtaining good quality soldered joint. To solder effectively, the tip of the soldering iron must be kept clean all times.

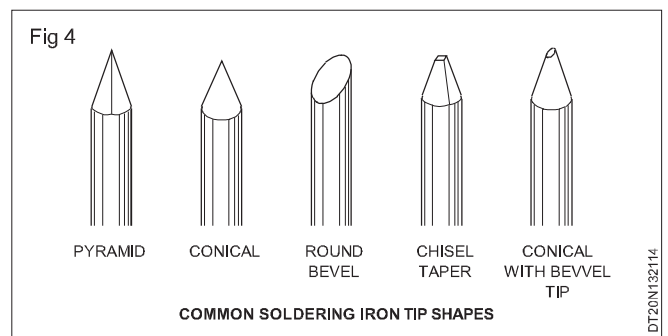

## Types of solders

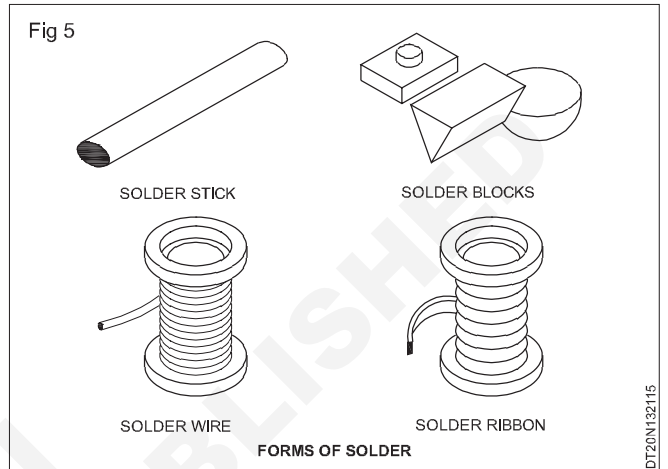

Solders are available in many forms as shown in Fig 5. The type to be chosen depends on, the type of soldering to be carried out. The wire type solder shown in Fig 5 is the most commonly used solder for hand soldering work, using low wattage soldering iron.

Solders available in the market may have different tin-lead proportion in it. For general electronic circuit soldering work, solder with 60% tin and 40% lead is most suited. This solder is commonly called 60/40 solder. This solder has been specially developed to possess superior properties required for electronic circuit work.

## Soldering FLUX

A protective oxide layer forms on the exposed surface of most metals. The rate at which the oxide layer is formed varies from metal to metal. The layer forms quickly on newly exposed metal, and over time, the layer slowly become quite thick.

This oxide layer on metals interferes with soldering. Hence, it must be removed before a soldered joint can be made.

The purpose of flux is to first dissolve the thin layer of oxide from the surface of the metals to be joined, and then form a protective blanket over them until the solder can flow over the joint surfaces to form the joint.

However, thick layers of oxide must be removed using an abrasive method as all types of flux are not capable of dissolving their oxide layers.

## Types of flux

There are several types of fluxes used in different types of soldering. The type of flux used for soldering electronic components is called **rosin**. Rosin is made from a resin obtained from the sap of trees.

Rosin flux is ideal for soldering electronic components because, it become active at the soldering temperature, but revert to an inactive state when cooled again. An additional advantage is that it is non-conductive.

The rosin has activators or halides added to it. The activators used in rosins are mild acids that become very active at soldering temperatures. These acids dissolve the oxide layer on the metals to be soldered.

Organic and inorganic acid fluxes are available. These fluxes are not suitable for soldering electronic circuits.

### Common forms of flux

Flux is available in a variety of forms to suit various types of application. Flux is available as a liquid, paste or a solid block. For most applications flux is often put in the solder itself during manufacture.

**Not all flux types are available in all forms. For hand soldering work on electronic circuits, the best form for the flux is either as a liquid or a paste.**

### Rosin cored solder

Several manufacturers produce solder wire with the flux already included in one or more cores running along its length as shown in Fig 6. This is known as **cored solder**.

The most popular type of cored solder for electronic hand soldering contains rosin type flux. Such solder is known as **rosin cored solder**.

When the solder is heated, the rosin flux melts before the solder. The rosin then flows out over the surface to be soldered ahead of the solder.

The amount of flux contained in the core is carefully controlled by the manufacturer and for most applications it will be sufficient. However, it is a common practice to apply additional liquid flux or flux paste to the joint, just prior to making the joint. This additional flux ensures that, sufficient flux available while the joint is being made. When the soldering has been completed, excess flux if any has to be removed.

Rosin-cored solder is available in different gauges as shown in Fig 6. It is important to choose a size suitable for the job at hand as given below;

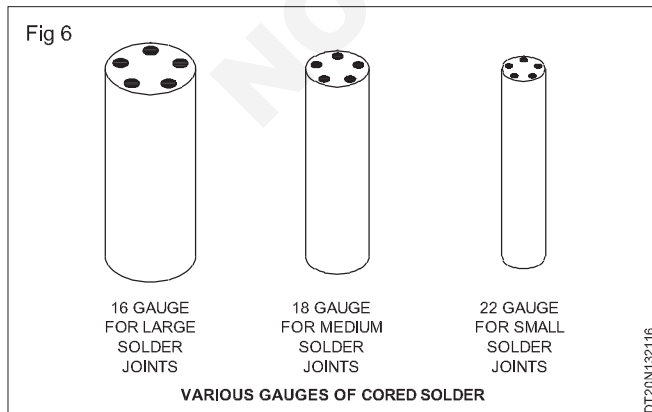

- use 22 gauge for small joints
- use 18 gauge for medium joints
- use 16 gauge for large joints.

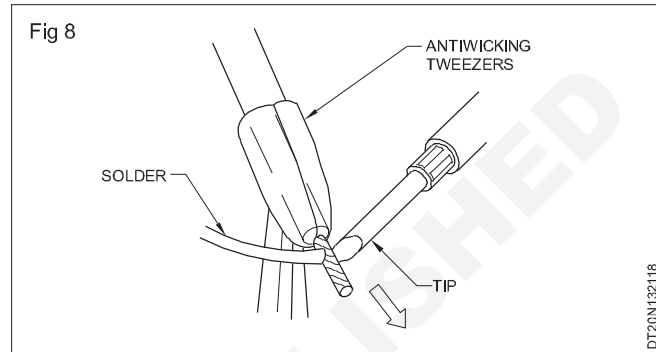
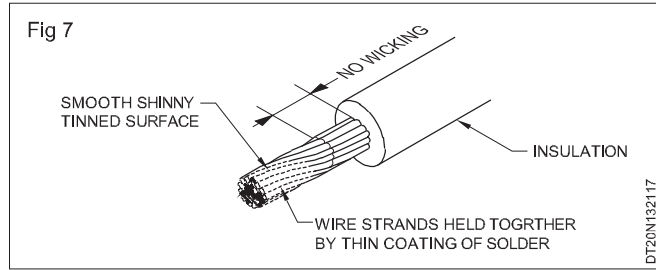

### Soldering Technique

#### Soldering a joint

Selection and preparation of the soldering materials is the most time consuming phase of making a solder joint. Heating the joint and applying solder is the least time consuming but, it is the most important part of the soldering process.

#### Critical factors during soldering

- 1 Controlling the temperature of the workpiece
- 2 Limiting of time that a workpiece is held at soldering temperature. These factors are specially critical while soldering electronic components like resistors, capacitors, transistors, ICs etc., Failure to correctly time and coordinate the heating of the joint and add solder, will result in a poor quality joint and may even damage the components.

#### Stages in soldering

The soldering process can be divided into several distinct stages or phases as given below:

- 1 Selection and preparation of materials.
- 2 Heating the joint and adding solder.
- 3 Cooling the joint.
- 4 Cleaning the joint.
- 5 Inspecting the joint.

#### Selection and Preparation of Materials

##### Selection of soldering iron wattage

Soldering irons are available in different wattage ratings starting from 10 watts to several 100 watts. The wattage of a soldering iron specifies the amount of heat it can produce. As a thumb rule, higher the physical dimension



of the workpiece, higher should be the wattage rating of the soldering iron. Some of the suggested wattage choices are given below:

- i For soldering less temperature sensitive components such as, resistors on lug boards, tag boards, use 25 to 60W iron. For soldering on printed circuit boards, use 10 to 25 W iron.
- ii For soldering highly temperature sensitive components such as, diodes, transistors and integrated circuits, use 10 to 25 watts iron.

### Selection of soldering iron tip

To ensure that the joint is heated to the required temperature ideally,

- the area of the tip face should be approximately equal to the area of the joint to be soldered
- the tip should be long enough to allow easy access to the joint.
- the tip should not be too long, as this may result in too low temperature at the tips working face.

In most soldering irons, the tip can be easily removed and replaced as shown in Fig 9.

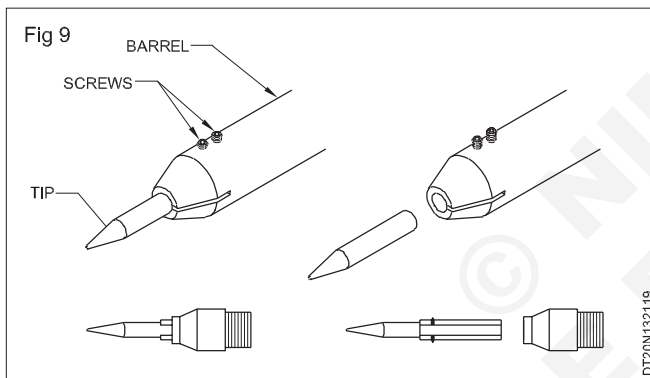

### Selection of tip temperature

Good quality soldering iron tips have numbers punched on them as shown in Fig 10. These numbers indicate the temperature to which the tip can be heated.

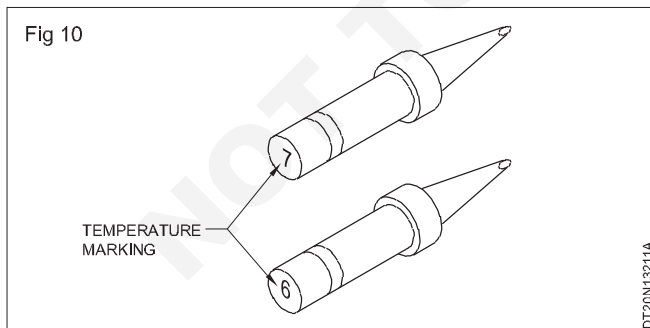

Tip No.	Temperature °C	Temperature °F
5	260	500
6	316	600
7	371	700
8	427	800

### Selection of tip shape

Suggested soldering tip shapes selection table is given below;

Type of soldering work	Soldering tip shape to choose
Wires, resistors and other passive components on to lug/tag boards	CHISEL TIP
All miniature electronic components except ICs on to lug boards and printed circuit boards (PCB)	BEVEL TIP
Integrated circuits (ICs) on to printed circuit boards (PCBs)	CONICAL TIP

### Selection of solder and flux

There are several sizes of the cored solders whose choice depends on the size of the joints to be soldered. Also the tin and lead percentage of the solder should be checked before using the solder. Different tin and lead combinations of solder need different temperatures for it to melt and reach the liquid state.

For electronic soldering applications, solder of tin and lead of 60/40 proportion is used. This solder proportion has a melting point of 200°C which is the required temperature for general purpose soldering irons.

While soldering to make a strong solder joint the flux should melt first, and then the solder. Therefore, while using rosin cored solder, cut off the first 5 to 10mm of the solder using a side cutter (as shown in Fig 11), so that any earlier melted portion of the solder blocking the rosin core is removed.

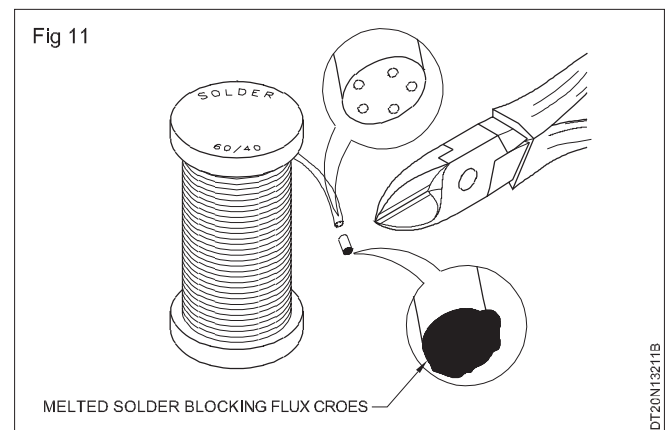

For ease of application, the flux used in addition to the cored flux in solder should be of paste form.

Flux is a chemical substance which has acidic properties. Therefore, it is advised not to touch flux by hand. Use a stick or a thin stiff brush to apply flux on workpieces. Hands should be washed after soldering work.

### Soldering stand

Soldering stand plays an important role of retaining the soldering iron tip temperature around the required soldering temperature. The soldering stand should not



allow the external temperature to cool the bit. At the same time the stand should not contain all the heat generated.

Soldering stands are specially designed as shown in Fig 12 to fulfill the above requirements. Such a design also prevents accidental burn injuries to the user of the soldering iron.

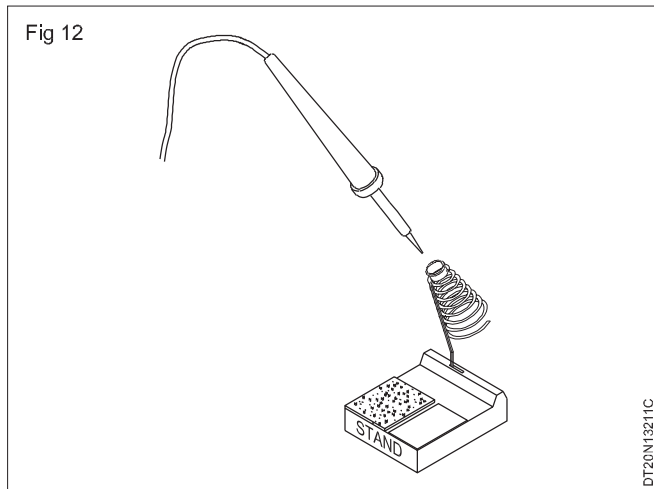

Another important requirement of a soldering stand is its mechanical stability. When the iron is taken out or placed in the stand frequently, the stand should not topple. An unstable stand is sure to cause burn injuries while carrying out serious soldering work.

### Inspection of soldering iron

Most soldering irons are powered by AC mains voltage. This voltage level is high and can give shock if one is careless. Soldering irons will generally have lengthy mains cable. While using the iron, the mains cable gets twisted and will have to bear physical strain. Because of this strain, the insulation of cable may get cut. This may lead to live wires protruding out. The live wires give severe electrical shocks if it touches the user.

Hence, a thorough inspection of the soldering iron is a must before using through it.

### Preparation of soldering iron for soldering

#### Heating the Joint and Adding Solder

Tips for heating and applying solder to a joint to be soldered are given below:

- Do not apply additional flux required for a joint in one place. Apply a small amount of flux around the joint. Do not allow the flux to flow outside the area to be soldered.
- Place the iron tip at the connection such that the tip gets maximum contact with parts to be joined as shown in Fig 13.
- Slowly feed the solder into the joint starting close to the soldering tip and moving towards the edge of the joint as shown in Fig 14.
- Continue applying the solder to the joint until complete wetting of the joint has been achieved and the joint has a concave fillet as shown in Fig 15.

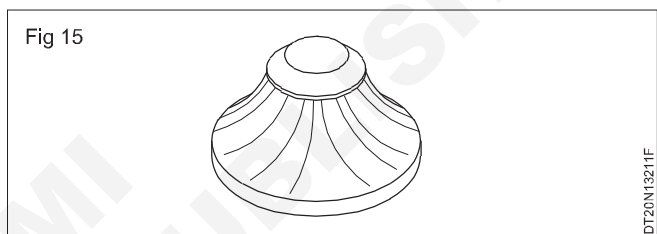
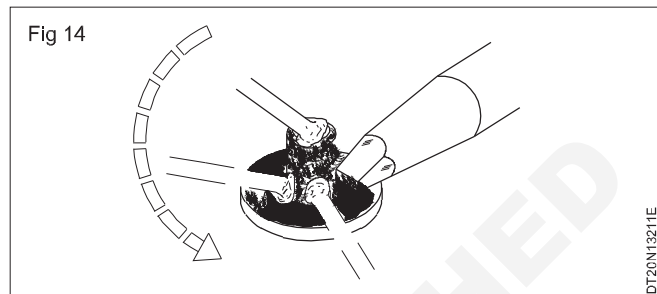
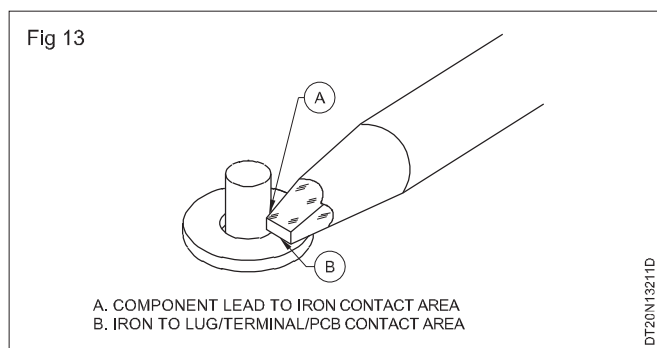

- After enough solder has been applied and solder removed, keep the soldering iron tip on the joint for a moment to ensure that all the flux on the joint has reached the soldering temperature. This will allow majority of the acids within the joint to break down, which otherwise will corrode the joint after a period of time.

Generally the time taken to make a good soldered joint is between 3 to 7 seconds from applying the soldering iron.

### Cooling the Joint

Tips for cooling a solder joint are given below:

- Allow the joint to cool without assistance. Do not blow air from your mouth or from any other source to cool the joint. Forced cooling, cools the joint much earlier than it has to, resulting in a dry or brittle solder joint which will lead to mechanical and electrical defects of the joint.
- Do not move any part of the joint while it is cooling. This disturbs the chemical bonding taking place. Movement of the joint while it is cooling results in a dry joint.

### Cleaning the Joint

When a solder joint is made, the amount of flux applied should be just sufficient to make a good joint. But, quite often, there will be a brown waxy substance left on the joint. This is nothing but the flux residue. In its original state this residue is corrosive. Hence, the flux residue or excess flux must be removed from the joint before soldering can be considered as complete.

If the flux residue and excess flux are not properly removed, their corrosive nature of the flux will gradually destroy the component leads and the circuit board. The flux residue is also *tacky* and, if not removed, will collect dust and debris often leading to circuit failure.

Removal of flux residue requires the use of solvents. The type of solvent depends on the flux used.

IsoPropyl Alcohol (IPA) is one of the solvents used for removing residual flux. It is available either undiluted or pre-mixed with water and can be obtained in pump sprays, aerosols, cans and drums depending on the quantity and style of use.

### Cleaning using water/IPA solution

Determine the right method of application. (spray or liquid). Apply the solvent to the soldered joint. Use a clean acid brush, or some other type of stiff brush, to gently scrub the joint as shown in Fig 16, to help dissolve the residue, taking care to avoid splashing the mixture.

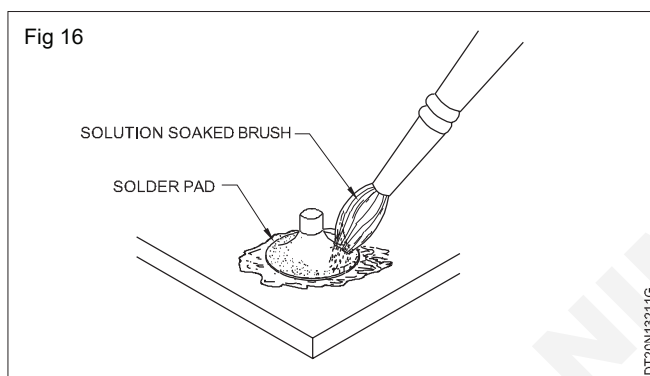

When the residue has been dissolved, dry the joint with a lint-free cloth to remove as much of the dissolved residue as possible.

### Don't 's While Soldering

- Do not use a poorly tinned soldering tip.
- Do not cool the tip of the iron by wiping it excessively on a damp sponge.
- Do not allow the solder to be carried to the joint on the tip of the soldering iron.
- Do not attempt to speed up the cooling of the joint by blowing on it.
- Do not move the soldered joint until the solder has cooled to solid state.
- Do not try and improve a bad solder joint by reheating. All the original solder must be removed and the joint preparation and soldering should be redone.

### Features of soldering iron

There are a number of features that the soldering irons posse need to be examined before a choice of a particular soldering iron is made. These include: size, wattage or power consumption, voltage method of temperature control, anti-static protection, type of stand available, and general maintenance and care issues.

**Size:** There is a wide variety of sizes of soldering iron available. Obviously those that are smaller will be more suited to fine work, and those that are larger will be more suited to the solder of items that are less delicate. The physical size will also run in parallel with the wattage or power consumption of the iron.

**Wattage or power consumption:** The power consumption or wattage of a soldering iron is often quoted. The wattage can vary. For basic non-temperature controlled irons, a wattage of 40 watts may be good for general work, and higher if heavy soldering is envisaged. For small PCB work, 15 or 25 watts is good value. For temperature controlled irons slightly higher wattages are common as the temperature control acts more quickly if more heat can be directed to the bit more quickly to compensate for removal of heat via the work item.

**Voltage:** While most soldering irons on sale in a particular will country have the correct mains voltage, 230V AC and there are also soldering irons that can run from 12 V. Some irons may be made for specialist applications where they need to run from low voltages.

**Temperature control:** Soldering irons use two main varieties of temperature control. The less expensive irons are regulated by the fact that when they come up to temperature, the loss of heat is the same as the heat generated. In other words they employ no form of electronic regulation. Other, more costly types have thermostatic control. This naturally regulates the temperature far better. Usually the temperature can be adjusted to the required value. These irons come into their own because when heat is drawn away by a large object being soldered, they will maintain their temperature far better. Those with no regulation may not be able to maintain their temperature sufficiently when soldering a large object, with the result that it is more difficult to melt the solder under these conditions.

**Anti-static protection:** With the increasing susceptibility of many electronic components, particularly the very advanced integrated circuit chips, static protection is becoming more of an issue. While most components being used by home constructors are often not damaged by static, some are. It is therefore a wise precaution to at least consider whether the soldering iron that is bought is one that has static protection.

**Stand:** The stand used for the soldering iron can be very important. With irons reaching temperatures of around 300°C it is necessary to ensure they are well protected. A good stand is essential therefore (Fig 17)

**Maintenance:** When using any soldering iron it is essential that spare parts can be obtained. The soldering iron "bits" used to undertake the actual soldering have a limited life and even though the rest of the iron may work for many years, it will be necessary to change the bits at regular intervals. Additionally it is worth ensuring for the more expensive soldering irons, such as those with temperature control, that spare parts are available should they need repair.

Fig 17

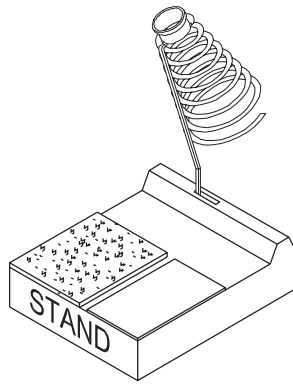

DT20N13211H

## Desoldering and desoldering tools

### Desoldering

Many a time it may be necessary to disconnect/remove components and wires from a soldered or wired circuit due to the following reasons;

- Component failure(open,short etc).
- Incorrect component installation(polarity,position etc).
- Faulty or defective solder connections(dry solder etc).
- Circuit modifications(replacing,removing components etc).

Disconnecting a component or wire from any soldered circuit involves two separate actions. These are:

- 1 **Desoldering the Connection** - this action involves removal of the solder from a joint
- 2 **Removal of the Component** - this action involves removing the component lead from the joint.

### De-soldering the connection

De-soldering is a process of heating a soldered joint, to melt the existing solder and removing the molten solder from the joint.

De-soldering makes it easy to separate or pull-out the components,wires from the joint without unnecessary damage to the components and wires.

The heat required to melt the solder is supplied by a soldering iron. But removal of the molten solder from the joint requires the use of one of the following;

- Plunger de-soldering tool or desoldering pump
- Wicking braid

But, in many cases, desoldering is done using a nose plier and a soldering iron. First, the joint to be disconnected is heated using the soldering iron. Once the solder at the joint melts, the component lead is pulled away using a nose plier. This method of desoldering can be used for heavy components with strong leads. But this method should not be used for desoldering thin lead delicate components such as transistors, integrated circuits etc., This is because, in this method there is likelihood of component getting overheated or the leads getting cut or leads getting detached from the body of the component.

## Plunger De-Soldering Tool

A typical plunger de-soldering tool is shown in Fig 18.

Fig 18

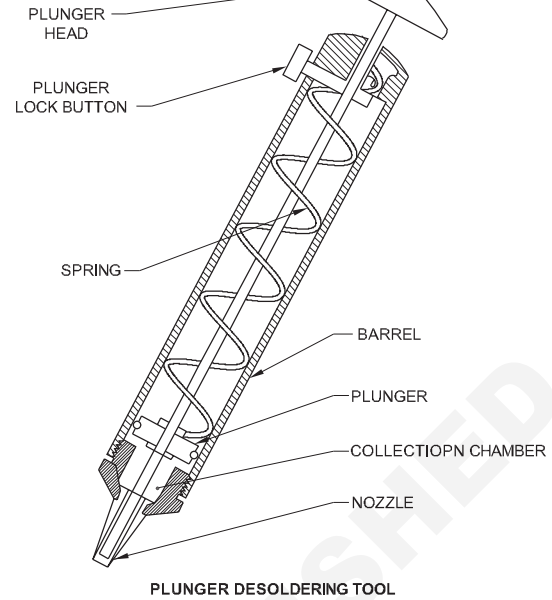

DT20N13211I

Plunger type desoldering tool is the most commonly used desoldering tool. This tool works on the principle of air suction. When the plunger head is pushed fully inside as shown in Fig 19, it gets locked inside with the help of the plunger button. This is known as cocking tool.

Fig 19

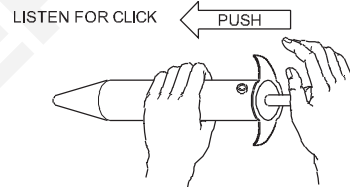

DT20N13211J

In this condition, the nozzle of the desoldering tool is kept almost touching the joint to be desoldered. If the joint is heated, the solder at the joint melts. If the plunger button of the desoldering pump is pressed, it releases the spring tension and moves the plunger up with a jerk. This causes the air to be sucked-in through the nozzle. Since the nozzle is now in contact with the molten solder, the molten solder is also sucked-in through the nozzle and gets collected in the collection chamber as shown in Fig 20.

Fig 20

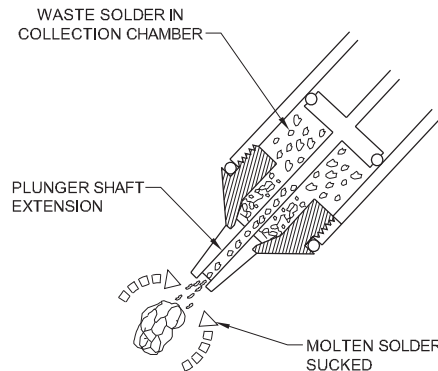

DT20N13211K

When the solder is removed using a plunger de-soldering tool, all the molten solder of a joint may not be sucked by the de-soldering tool at the first attempt, the joint must be reheated and the solder removed in two or three attempts.

After doing one suction of molten solder, while cocking the tool for second suction, face the nozzle into a dirt collector. This is because, the solder collected at the tip of the nozzle gets pushed out every time the tool is cocked as shown in Fig 21.

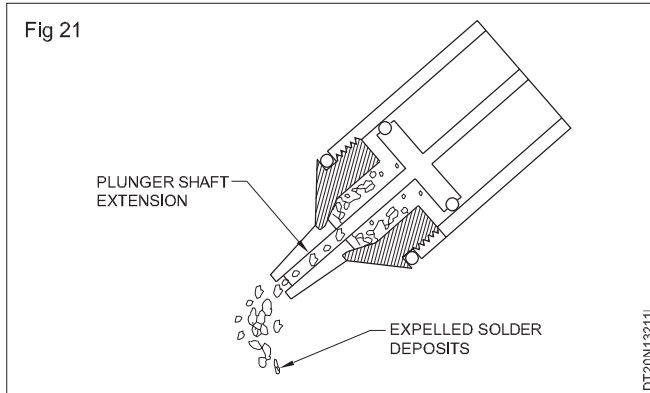

After several operations, the waste solder collected within the tool will begin to interfere with its operation. To prevent clogging of nozzle, this solder must be removed periodically and the tool must be cleaned and lubricated as shown in Fig 22.

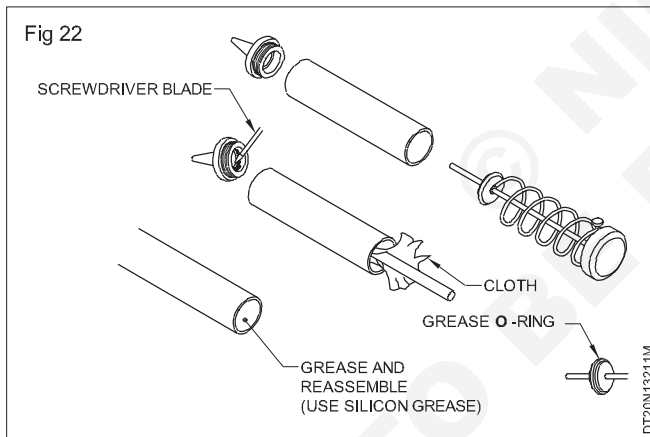

### Wicking Braid

Wicking braid as shown in Fig 23 is another simple de-soldering aid. This is made of copper and is soaked in flux. Wicking braid is nothing but a tape made of thin strands of copper knitted to form a mesh as shown in Fig 23.

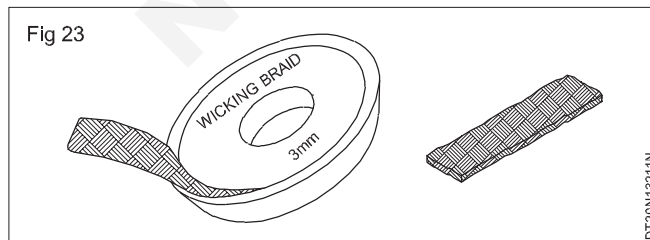

A wicking braid relies on the tendency of the hot solder to flow towards the heat source. When a soldered joint

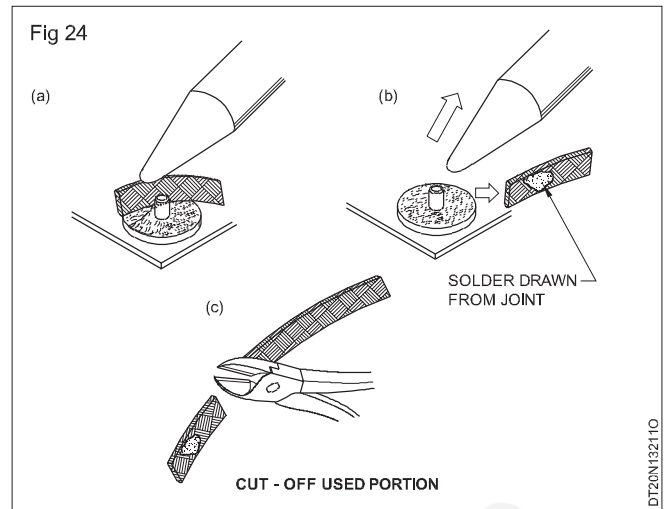

is heated via a wicking tape as shown in Fig 24a, the molten solder gets drawn into the wicking braid as shown in Fig 24b. Thus the joint is now free from solder and the component can be removed easily.

The flux content of the wicking braid varies from brand to brand. Generally, the higher the level of flux in the braid, the more efficient it will be at drawing the solder from the joint.

Wicking braids are available in small, hand-held rolls and is supplied in a range of sizes from 0.8 to 6 mm wide so that the correct width of wicking braid can be selected for the joint to be de-soldered as shown in Fig 25.

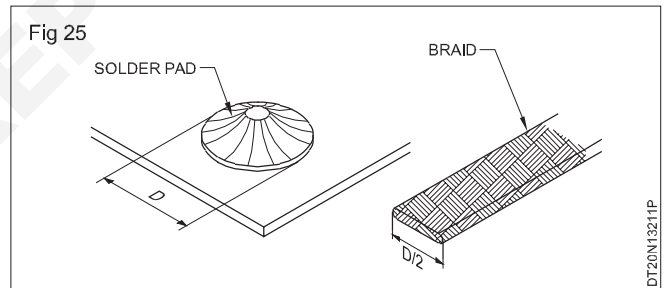

De-soldering using a wicking braid is commonly used for removing miniature components soldered on printed circuit boards (PCB's).

### Removal of component

When solder is removed from the joint, the component can then be removed from the circuit board. If a component was soldered using clinched lead method as shown in Fig 26, it is essential to remove the bridge of solder holding the lead.

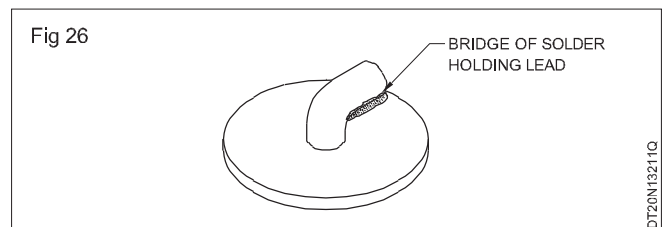



To remove the solder bridge, follow the steps shown in Fig 27

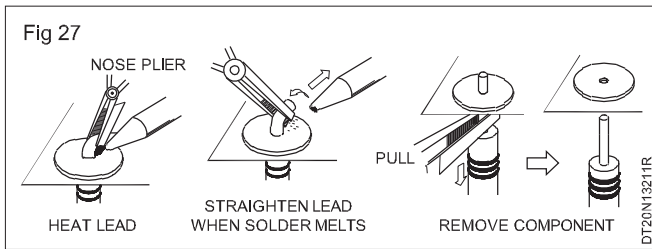

There are other special tools used for de-soldering such as De-soldering iron and multi-contact de-soldering block.

### Soldering and desoldering station

Printed circuit board have changed the face of Electronics industry. Comparing the today's PCBs with the old hardwired, steel chassis devices, they lack the strength making them vulnerable to cracks and related defects. It may sometimes be possible to repair a broken PCB but it is very difficult process. Locating the cracked copper trace on the PCB is the most difficult part of the repair PCBs get damaged very easily. A little rough handling during installation or troubleshoot will invite a crack in the trace. While placing or removing PCBs from their sockets, one needs to put little extra force. This itself might cause a crack in the trace. Similarly when a component on a PCB is removed or inserted a little more heat for a little long period will make copper trace to come off the board's substrate. There may result a microscopic crack in the trace.

### Repair of broken trace using a conductive pen

- 1 Locate the broken trace to be repaired.
- 2 Using the Emery cloth, remove the protective green overcoat from the broken trace. Clean the trace ½ inch to both sides of the break until it shows a bright copper colour.

- 3 Using the Silver Conductive ink pen, apply a liberal coating of ink across the break and let the board set until the ink is completed dry. Different inks have different drying times so read the data sheet that came with your pen.
- 4 Using the Green Overcoat pen, apply a generous coating of the protective coating and let the board set until dry.
- 5 Set your DMM to the Ohms range and take a reading across the repaired section of the trace. The meter should read 0 Ohms. Some meters will read the resistance of their internal fuse so if you get a reading 0.5 Ohms or less your repair was a successes.

If the circuit board is subject to vibration or flexing, conductivity ink or paint isn't the repair method of choice.

### Bridging the Gap

- 1 Locate and prepare clean the broken trace as you did in steps one and two mentioned above. Plug in the soldering iron or turn on the soldering station. When hot, clean the tip on the wet sponge.
- 2 "Tin" the freshly cleaned tip by applying a thin coating of Rosin Core solder. A properly tinned tip will appear bright, silver in color. A properly - tinned tip conducts heat faster and you are less apt to do further damage to the PC Board during the repair .
- 3 Tin the trace to be repaired by coating the copper trace with solder
- 4 Cut a short piece of hook - up wire and strip ¼ inches of insulation from each end.
- 5 Tin the bare copper ends of the jumper.
- 6 Solder the jumper across the break in the trace

## Introduction of electrical components and its parameters.

**Objectives:** At the end of this lesson you shall be able to

- state use of meters in different circuits
- measurement of different electrical parameters.

**Introduction:** The Components used in electronic circuits can broadly grouped under two headings. – passive components – active components  
**Passive components:** Components like resistors, capacitors, and inductors used in electronic circuit are called as passive components. These components by themselves are not capable of amplifying or processing an electrical signal. However these components are equally important in electronic circuit as that of active components, without the aid of passive components, a transistor (active components) cannot be made to amplify electrical signal.

**Resistors:** The components whose purpose to introduce resistance in the circuit is called as resistors. Other details of resistors are dealt in earlier lessons.

**Capacitor:** The components whose purpose to introduce capacitance in the circuit is called as capacitor. The unit of capacitance is 'FARAD'. Commercially capacitors are available in Microfarad ( $\mu\text{F}$ ), Nanofarad (nF) and Picofarads (pF)

The colour coding of capacitors and resistors are same. Where as, in the case of fixed capacitors, the colour coded unit shall be in Picofarads. For letter coding, incase of capacitor, the letter 'p', 'n', ' $\mu$ ' shall be used as multipliers. Where  $p = 10^{-12}$ ,  $n = 10^{-9}$  and  $\mu = 10^{-6}$  farads, and letter code for tolerance on capacitor is the same as in resistor.

**Inductor:** The ability of the conductor to induce voltage in itself, when the current changes in it is called as self inductance (or) simply inductance. A coil introduced in a circuit to have inductance is called as inductor. Different type of inductors are shown in Fig 1. The unit of inductance is "Henry". Commercially a coil may have inductance in Millihenry (10-3H), or in Microhenry (10-6H).

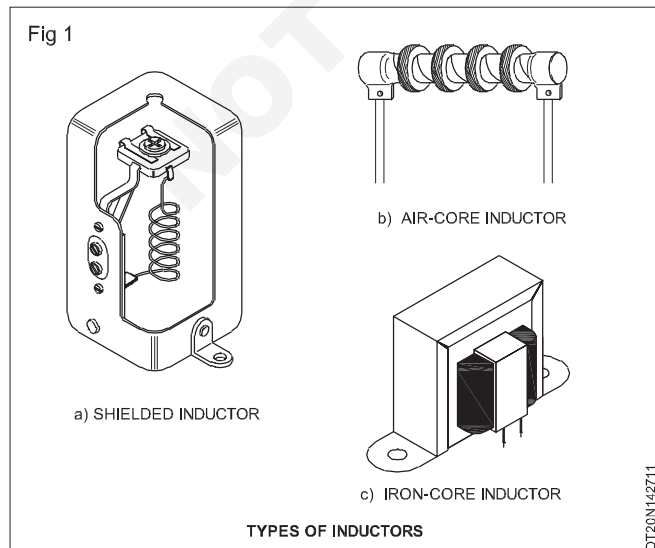

**Transistor:** Figure 2a shows the physical appearance of transistors. There are two symbols to represent a transistor. (Fig 2b). The selection of a symbol is based on either the NPN or the PNP type of transistor.

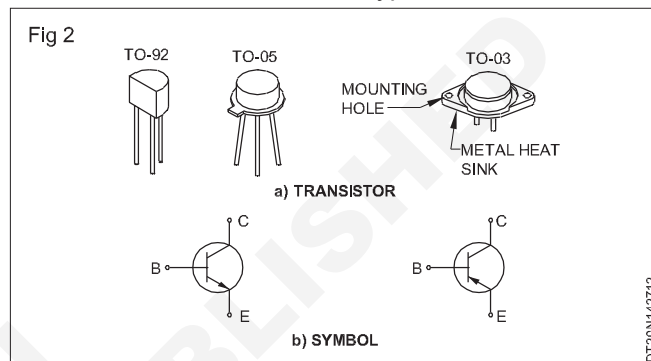

Transistor is an active device which can be compared to the heart of modern electronics. It accepts small electrical signal either in the form of current or voltage at the input and then amplifies (increase the amplitude) and provides a large signal at the output as in Fig 3. Transistors are used in almost all electronic gadgets such as radio, TV, tape recorder, computer etc.,

**Direct current (DC):** Direct current (DC) is the current that flows only in one direction in a circuit. (Fig 3) The current in this type of circuit is supplied from a DC voltage source. Since the polarity of a DC source remains fixed, the current produced by it flows in one direction only.

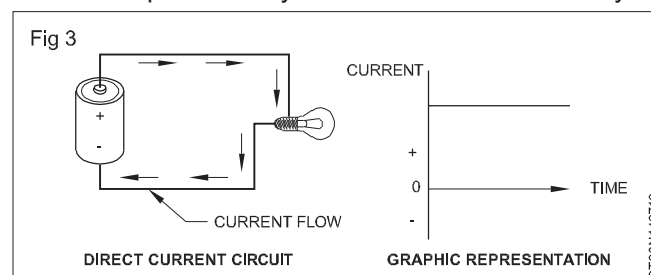

**Alternating current (AC):** An alternating current (AC) circuit is one in which the direction and amplitude of the current flow change at regular intervals. The current in this type of circuit is supplied from an AC voltage source. The polarity of an AC source changes at regular intervals resulting in a reversal of the circuit current flow. Alternating current usually changes in both value and direction. The current increases from zero to some maximum value, and then drops back to zero as it flows in one direction. This same pattern is then repeated as it flows in the opposite direction. The wave-form or the exact manner in which the current increases and decreases is determined by the type of AC voltage source used. (Fig 4)



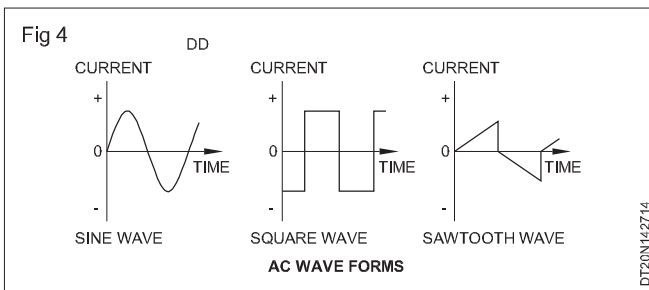

### Alternating voltage

AC supply sources change their polarity constantly, and consequently the direction of voltage also magnitude. The voltage supplied to our homes by power plants is alternating. Fig 5 shows a sinusoidal alternating voltage over time (wave-form).

AC supply is expressed by the effective value of the voltage, and the number of times it changes in one second is known as frequency. Frequency is represented by 'F' and its unit is in Hertz(Hz).

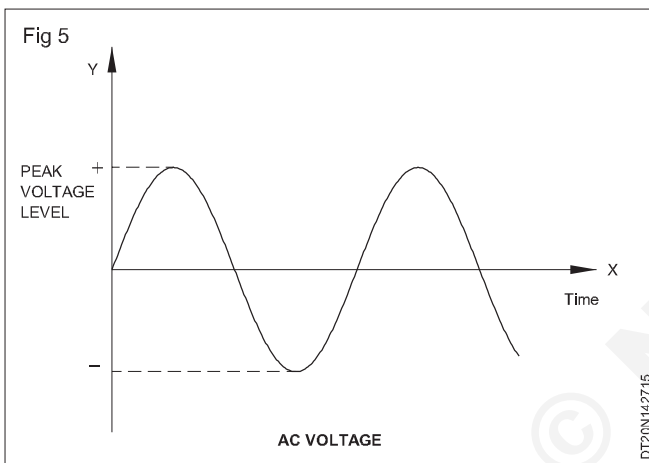

**Frequency:** The frequency of an AC sine wave is the number of cycles produced per second.(Fig 6) The SI unit of frequency is the hertz (Hz). For example, the 240V AC at your home has a frequency of 50 Hz.

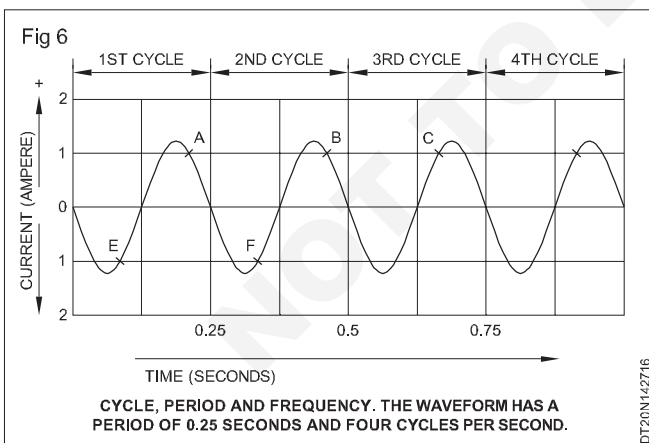

### Duty cycle

This control on the function generator changes the ratio of high voltage to low voltage time in a square wave signal, i.e. changing the waveform from a square wave with a 1:1 duty cycle to a pulse waveform, or a triangular waveform with equal rise and fall times to a sawtooth. Function generator usage.

## Introduction to electrical and electronic measuring instruments.

### Types of measuring Instruments

- Following are the most commonly used electronic instruments.
  - i Ammeter
  - ii Voltmeter
  - iii Ohmmeter
  - iv Multi-meter
  - v Clamp Meter

#### i Ammeter

- Ammeter is an electronic instruments device used to determine the electric current flowing through a circuit. Ammeters measuring current in milli-ampere range is known as milli-ammeters. (Fig 7)

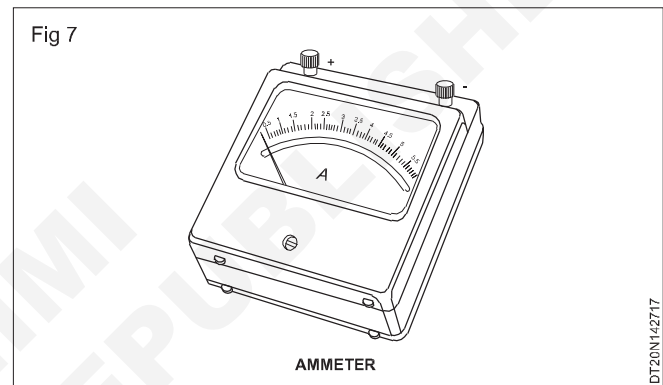

- Ammeters are connected in series to the circuit whose current is to be measured. Hence this electronic instruments are designed to have as Very Low resistance/ loading as possible.
- There are two types of ammeters: DC ammeter, and AC ammeter.
- DC ammeter measures the DC current that flows through any two points of an electric circuit. Whereas, AC ammeter measures the AC current that flows through any two points of an electric circuit.

#### ii Voltmeter

- Voltmeter is an electronic instruments used in an electric circuit to determine the potential difference or voltage between two different points. (Fig 8)

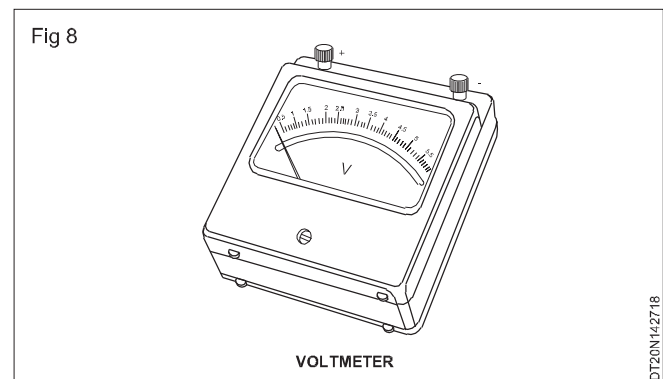

- Voltmeters are usually connected in parallel (shunt) to the circuit. Hence they are designed to have High resistance as possible to reduce the loading effect.
- There are two types of voltmeters: DC voltmeter, and AC voltmeter i.e RMS value of Voltage.
- DC voltmeter measures the DC voltage across any two points of an electric circuit, whereas AC voltmeter measures the AC voltage across any two points of an electric circuit.

### iii Ohmmeter

- Ohmmeter is used to measure the value of Resistance between any two points of an electric circuit. It can also be used for finding the value of an unknown resistor.
- There are two types of ohmmeters: series ohmmeter, and shunt ohmmeter.
- In series type ohmmeter, the resistor whose value is unknown and to be measured should be connected in series with the ohmmeter. It is useful for measuring high values of resistances.
- In shunt type ohmmeter, the resistor whose value is unknown and to be measured should be connected in parallel (shunt) with the ohmmeter. It is useful for measuring low values of resistances.(Fig 9)

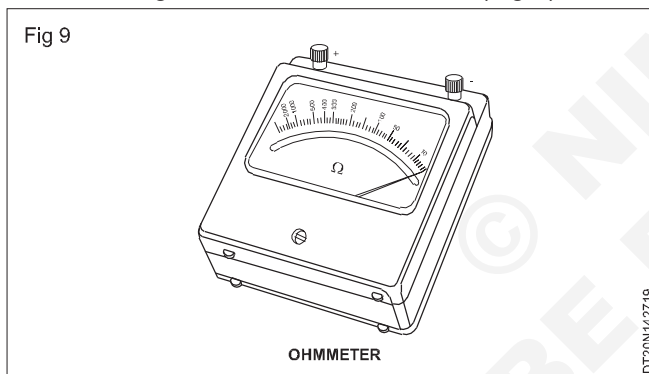

### iv Multimeter

- Multi-meter is an electronic instrument used to measure the quantities such as voltage, current & resistance one at a time.
- This Multi-meter is also Known as Volt-Ohm-Milliammeter (VOM).
- It can be used to measure DC & AC voltages, DC & AC currents and resistances of several ranges.

Fig 10

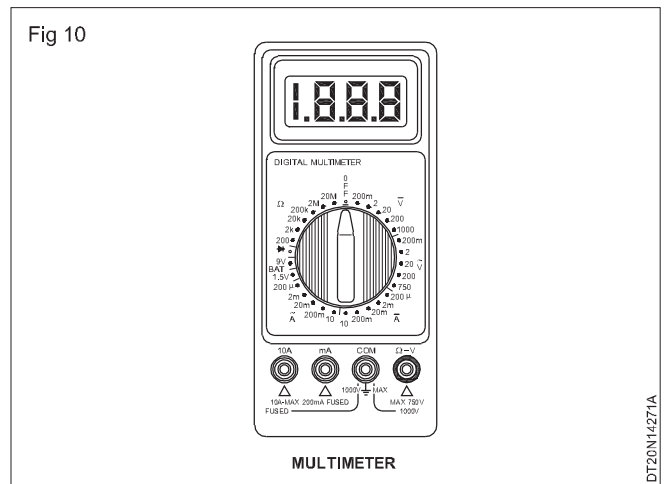

- A practical multi-meter is shown in the figure, which can be used to measure various high resistances, low resistances, DC voltages, AC voltages, DC currents, & AC currents. Different scales and range of values for each of these quantities are marked in the figure. (Fig 10)

### v Clamp meter

- A clamp meter is an electrical test tool that combines a basic digital multi-meter with a current sensor. It is also called a Tong Tester.
- Clamps measure current. Probes measure voltage. Having a hinged jaw integrated into an electrical meter allows technicians to clamp the jaws around a wire, cable or other conductor at any point in an electrical system, then measure current in that circuit without disconnecting/de-energizing it.
- Beneath their plastic mouldings, hard jaws consist of ferrite iron and are engineered to detect, concentrate and measure the magnetic field being generated by current as it flows through a conductor. (Fig 11)

Fig 11

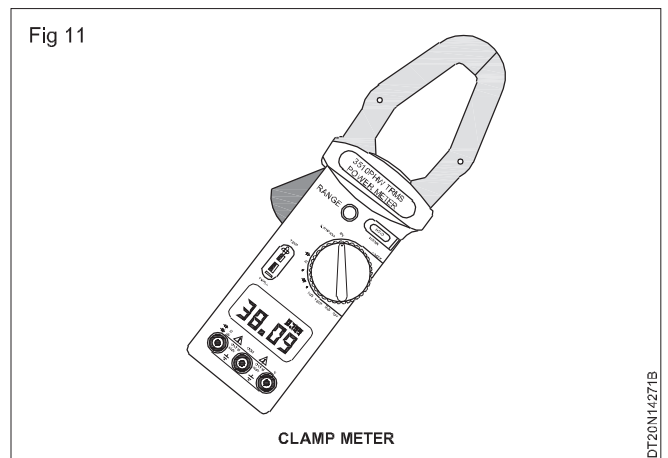

# Introduction to electrical and electronic measuring instruments.

**Objectives :** At the end of this lesson you shall be able to

- define digital storage oscilloscope
- draw the block diagram and explain the functions of each block
- list the functions of each control on the front panel
- explain principle, specification and applications of function generator.

## Working Principle of Multimeter

A Multimeter is an instrument in which the function of an ammeter, voltmeter and ohmmeter are all incorporated for measurement of current, voltage and resistance. Some manufactures call this as VOM meter as this meter is used as a volt, ohm and milliammeter. The multimeter uses the basic d' Arsonval (P.M.M.C) movement for all these measurements. This meter has facilities through various switches to change the internal circuit to convert the meter into a voltmeter, ammeter or ohmmeter.

The three most commonly measured electrical quantities are current, voltage and resistance. Current is measured by an ammeter, voltage by a voltmeter and resistance by an ohmmeter.

A single instrument used for measuring all the above three quantities is known as a multimeter. It is a portable, multi range instrument.

It has a full scale deflection accuracy of  $\pm 1.5\%$ . The lowest sensitivity of multimeters for AC voltage range is 5 kW/ volts and for the DC voltage range it is 20 kW/ volts. The lowest range of DC is more sensitive than the other ranges.

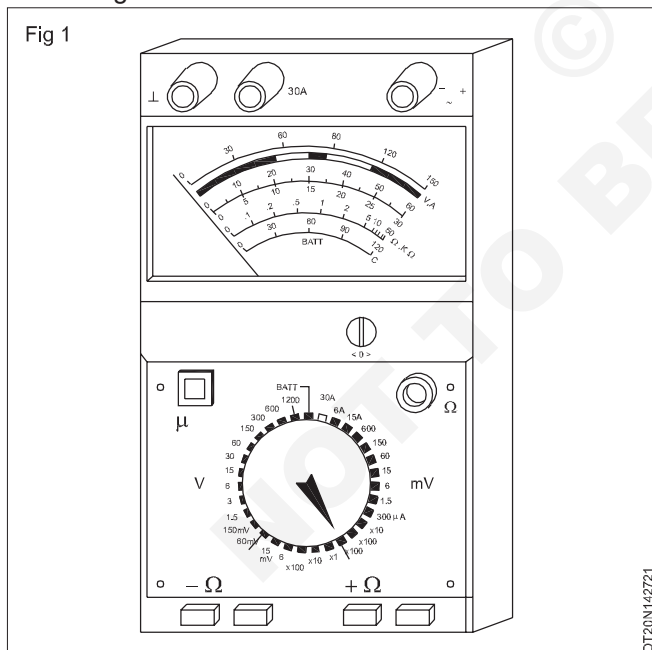

Fig 1 show typical multimeters.

## Construction of a multimeter

A multimeter uses a single meter movement with a scale calibrated in volts, ohms and milliamperes. The necessary multiplier resistors and shunt resistors are all contained within the case. Front panel selector switches are provided to select a particular meter function and a particular range for that function.

On some multimeters, two switches are used, one to select a function, and the other the range. Some multimeters do not have switches for this purpose; instead they have separate jacks for each function and range.

Batteries/cells fixed inside the meter case provide the power supply for the resistance measurement.

The meter movement is that of the moving coil system as used in DC ammeters and voltmeters.

Rectifiers are provided inside the meter to convert AC to DC in the AC measurement circuit.

## Parts of a multimeter

A standard multimeter consists of the main parts and controls, as shown in Fig 1.

## Controls

The meter is set to measure the current, voltage (AC and DC) or resistance by means of the FUNCTION switch.

The meter is set to the required current, voltage or resistance range - by means of the RANGE switch.

The example in Fig 1 shows the switch set to 25V DC of a meter having the function and the range selected by a single switch.

## Scale of multimeter

Separate scales are provided for:

- resistance
- voltage and current.

The scale of current and voltage is uniformly graduated.

The scale of the ohmmeter is non-linear. That is, the divisions between zero and infinity ( $\infty$ ) are not equally spaced. As you move from zero to the left across the scale, the divisions become closer together.

The scale is usually 'backward', with zero at the right.

## digital storage oscilloscope

Digital Storage Oscilloscopes (DSO) Digital oscilloscopes are often referred to as digital storage oscilloscope (DSO) or digital sampling oscilloscopes (DSO). The concept behind the digital oscilloscope is somewhat different to an analog scope. Rather than processing the signals in an analog fashion, the DSO converts them into a digital format using an analog to digital converter (ADC), then it stores the digital data in the memory, and then processes the signals digitally, finally it converts the resulting signal in a picture format to be displayed on the screen of the scope. Since the waveform is stored in a digital format, the data can be processed either within the oscilloscope

itself, or even by a PC connected to it. One advantage of using the DSO is that the stored data can be used to visualize or process the signal at any time. The analog scopes do not have memory therefore the signal can be displayed only instantaneously. The transient parts of the signal (which may vanish even in milliseconds or microseconds) can not be observed using an analog oscilloscope. The DSO's are widely used in many applications in view of their flexibility and performance. Figure 2 shows the block diagram of DSO as consists of, 1 Data acquisition 2 Storage 3 Data display. Data acquisition is earned out with the help of both analog to digital and digital to analog converters, which is used for digitizing, storing and displaying analog waveforms. Overall operation is controlled by control circuit which is usually consists of microprocessor. Data acquisition portion of the system consist of a Sample-and-Hold (S/H) circuit and an analog to digital converter (ADC) which continuously samples and digitizes the input signal at a rate determined by the sample clock and transmit the digitized data to memory for storage. The control circuit determines whether the successive data points are stored

in successive memory location or not, which is done by continuously updating the memories. When the memory is full, the next data point from the ADC is stored in the first memory location writing over the old data. The data acquisition and the storage process is continues till the control circuit receive a trigger signal from either the input waveform or an external trigger source. When the triggering occurs, the system stops and enters into the display mode of operation in which all or some part of the memory data is repetitively displayed on the cathode ray tube. In display operation, two DACs are used which gives horizontal and vertical deflection voltage for the CRT Data from the memory gives the vertical deflection of the electron beam, while the time base counter gives the horizontal deflection in the form of staircase sweep signal. The screen display consist of discrete dots representing the various data points but the number of dot is very large as 1000 or more that they tend to blend together and appear to be a smooth continuous waveform. 2 The display operation ends when the operator presses a front-panel button and commands the digital storage oscilloscope to begin a new data acquisition cycle.

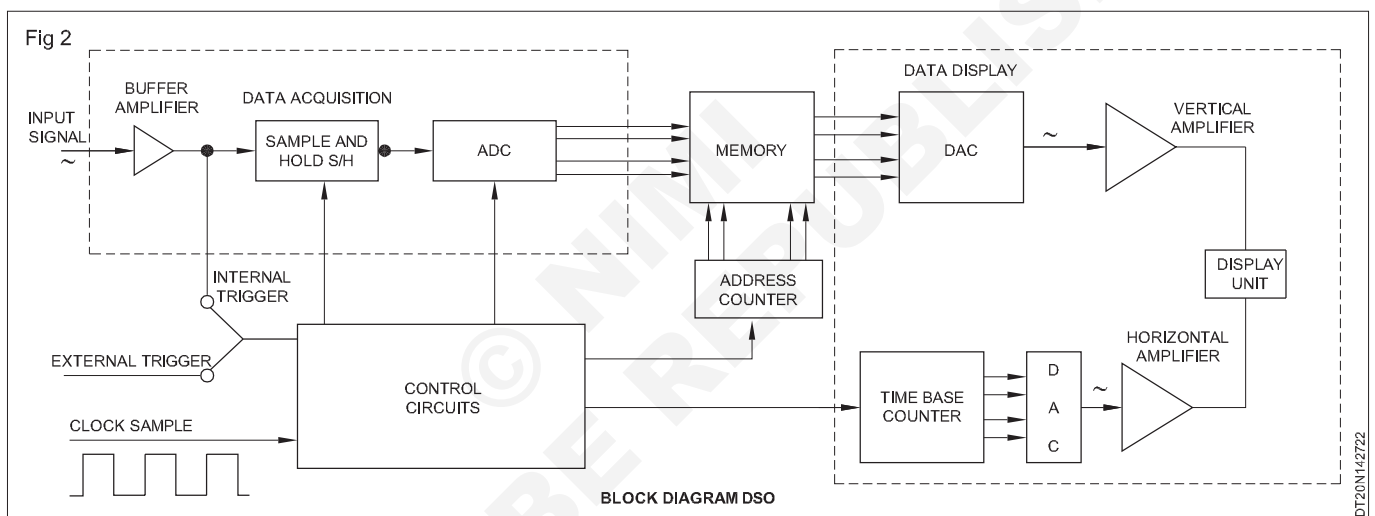

### Arbitrary waveform generator

Arbitrary waveform generator (AWG) is sophisticated electronic test equipment that generates waveforms based on stored digital data. The AWG can create virtually any type of waveform with high precision and accuracy. It is designed for generating a wide variety of basic waveforms such as Sine, Square, Ramp, Pulse, Noise signals and arbitrarily defined wave shapes also as its output.

AWG can generate repetitive or single shot waveforms either with internal or outside triggering source. It can create very specific waveform for use in testing a variety of applications. The output is from less than 1 Hz to several MHz with variable amplitude and adjustable DC offset.

AWG uses synthesizer circuits by the digital signal processing techniques, they generate desired output signal waveform and it is available across two channels either CH1 or CH2 using BNC connector with 50 Ohms output impedance.

It also include additional features such as higher frequency capability, variable symmetry, frequency sweep, AM, FM, PM, PWM, ASK, FSK, PSK modulations either with internal source or external source for modulation. The front panel and the rear panel of a typical Arbitrary waveform generator is shown in Fig 3 below.

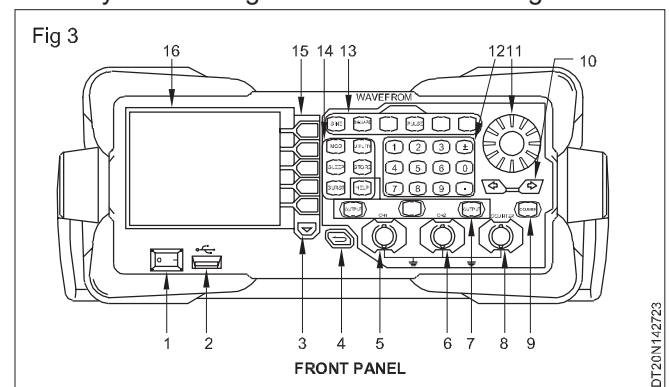

AWGs are contained within digital oscilloscope with a minimum of 10cm TFT colour LCD display. The content displayed on the LCD screen that shows you the picture of output waveform also be saved onto USB

storage media device as a picture file (\*.BMP) and the saved file can be read on / or edited in the AWG.

A numeric key pad is provided on the front panel for inputting parameters and a rotary knob is provided to move the direction of cursor to select the digit or character to be edited.

AWG features though menus controlled by function keys provided to set desired output waveform. By pressing that particular key on the panel, Sine, Square, and Ramp, Pulse, Noise signals or arbitrary waveform signals generated. There is backlight provided to turn on the selected function key.

In addition a digital frequency counter is a special feature of AWG. By connecting the unknown frequency signal and pressing the key for counter function it directly display the result on the screen.

The rear panel of a typical Arbitrary waveform generator is shown in Fig 4

On the rear panel sockets/ connectors are provided for Ch1/Ch2/Sync/Ext.ModlTrig/FSK functions. BNC female

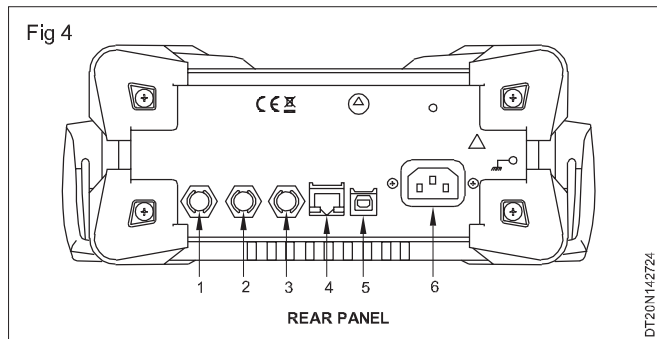

connector with suitable impedances are used for the functionality.

In some models a 10MHz- In/Out socket is provided to connect the clock signal generated by the internal crystal oscillator inside the generator or 'accept the external 10MHz clock signal when external source selected.

USB socket for connectivity to a computer or to a PictBridgeNprinter to print the contents displayed on the screen. And of course a three pin panel mount socket for 240V AC mains power supply input also provided.



## Introduction of different types of drone batteries and its specifications.

**Objectives:** At the end of this lesson you shall be able to

- explore the different types of batteries used in drone
- state the battery specifications
- state the significance of batteries
- state the charging circuits of batteries
- explore the BMS
- draw the block diagram of BMS.

### Types of Batteries used in drone

- 1 Nickel metal hydride (NiMH)
- 2 Nickel Cadmium (NiCd)
- 3 Li-Po (Lithium Polymer)
- 4 Li-ion (Lithium Ion)

#### Nickel metal hydride

The negative electrode of the NiMH battery is made from a hydrogen-absorbing alloy and sometimes many different inter-metallic compounds. The positive electrode is made of nickel-oxide hydroxide.

- NiMH Cell Features Include:
- High Discharge Rate
- Long Life Span
- Wide Operating Temperature (-30C to +85C)

#### Nickel Cadmium (NiCd)

In a nickel-cadmium battery, the redox material is used as a base, and around it, the layer of nickel and a separator are used.

Charge/discharge efficiency: 70–90%

Cycle durability: 2,000 cycles

Nominal cell voltage: 1.2 V

Self-discharge rate: 10%/month

Specific power: 150 W/kg

#### Li-Po

A lithium-polymer (LiPo, LIP or Li-Poly) battery is a type of rechargeable battery that uses a soft polymer casing so that the lithium-ion battery inside it rests in a soft external “pouch.” It may also refer to a lithium-ion battery that uses a gelled polymer as an electrolyte. However, the term commonly refers to a type of lithium-ion battery in a pouch format.

#### Li-ion

Lithium-ion (Li-ion) are made of three different parts, an anode (a negative terminal) made of lithium metal, a cathode (positive terminal) made up of graphite and a separating electrolyte layer between them to prevent short-circuiting. Whenever we charge our batteries, through a chemical reaction, ions from the negative terminal travels towards the positive terminal where energy is stored. As the battery discharges, ions travel back again to the anode.

Fig 1

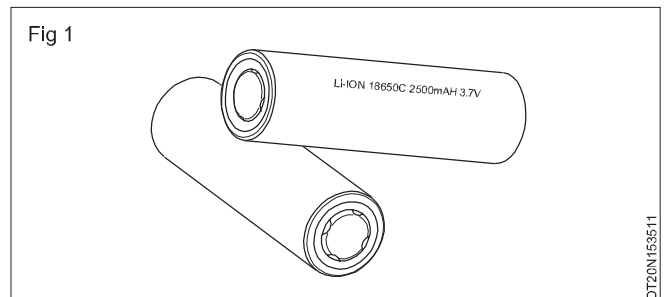



Chemistry	Cell Voltage	Energy Density (MJ/kg)	Comments
NiCd	1.2	>0.14	<p>Inexpensive.</p> <p>High/low drain, moderate energy density.</p> <p>Can withstand very high discharge rates with virtually no loss of capacity.</p> <p>Moderate rate of self discharge.</p> <p>Reputed to suffer from memory effect (which is alleged to cause early failure).</p> <p>Environmental hazard due to Cadmium - use now virtually prohibited in Europe.</p>
NiMH	2.2	>0.14	<p>Moderately expensive.</p> <p>Moderate energy density.</p> <p>Moderate rate of self discharge.</p> <p>Higher discharge rates result in considerable loss of capacity.</p> <p>Does not suffer from memory effect.</p> <p>Environmental hazard due to Lead.</p> <p>Common use - Automobile batteries.</p>
Lithium ion	3.6	>0.46	<p>Very expensive.</p> <p>Very high energy density.</p> <p>Not usually available in "common" battery sizes (but see RCR-V3 for a counter-example).</p> <p>Very common in laptop computers, moderate to high-end digital cameras and camcorders, and cellphones.</p> <p>Very low rate of self discharge.</p> <p>Volatile: Chance of explosion if short circuited, allowed to overheat, or not manufactured with rigorous quality standards.</p>

## Battery

The most commonly used battery in drone is a Lipo and Li-ion battery of the type used in drone.

Understand different specifications

LiPo batteries are labeled with a few important pieces of information, including: battery capacity, voltage, cell configuration and discharge rate.

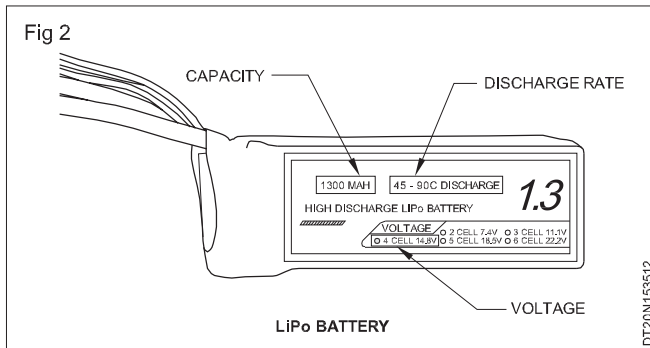

### LiPo Battery Capacity

Capacity measured in mAh (milliamp-hours); it indicates how long the battery will be last. The greater the value, the “longer the battery” will last.

For Example, a battery is rated at 2200 mAh, then the “runtime is calculated” as

$$\text{Capacity} = \frac{\text{mAh}}{\text{maximum Current}}$$

$$\frac{2200}{1000} \times \frac{1}{5.5} \times \frac{60}{1} \approx 24\text{min}$$

### Battery Voltage Rating

The voltage rating of the battery uses to determine motor speed and amperage.

All brushless motors have the Kv ratings which indicate It indicates the number of “revolutions per minute” (rpm) that a motor turns when 1V (one volt) is applied with no load attached to that motor.

### Cell Configuration

The cell configuration is mention by manufacture on the label indicates the number and layout of cells in the battery.

In case of LiPo battery one LiPo cell has a nominal voltage of 3.7 V. A 4S battery would have four LiPo cells in series (S), giving a 14.8 V battery i.e., 4 x 3.7 V = 14.8 V.

### Discharge/ C Rating

The C-Rating is a show how quickly energy can be discharged from the battery.

$$\text{C-Rating} = \text{mAh} \times \text{discharge}$$

For example, if a “battery has a capacity of 2200 mAh and a discharge of 25C, then the maximum continuous discharge” is:

$$\frac{2200}{1000} \times 25 = 55 \text{ A}$$

**Table 1:** Lithium Polymer cell ratings and associated voltage scenarios.

S Rating (# cells)	Nominal voltage	Fully charged voltage	Recomm ended Loaded Discharge voltage	Recom mended Resting Discharge voltage	Fully Dis- charged voltage
1s	3.7v	4.2v	3.5v	3.7v	3.0v
2s	7.4v	8.4v	7.0v	7.4v	6.0v
3s	11.1v	12.6v	10.5v	11.1v	9.0v
4s	14.8v	16.8v	14.0v	14.8v	12.0v
Ns	N*3.7v	N*4.2v	N*3.5v	N*3.7v	N*3.0v

**Table 2:** Lithium ion cell ratings and associated voltage scenarios.

S Rating (# cells)	Nominal voltage	Fully charged voltage	Recomm ended Loaded Discharge voltage	Recom mended Resting Discharge voltage	Fully Dis- charged voltage
1s	3.7v	4.2v	2.7v	3.0v	2.5v
2s	7.4v	8.4v	5.4v	6.0v	5.0v
3s	11.1v	12.6v	8.1v	9.0v	7.5v
4s	14.8v	16.8v	10.8v	12.0v	10.0v
Ns	N*3.7v	N*4.2v	N*2.7v	N*3.0v	N*2.5v

### How to Choose a LiPo Battery for Your Drone

There is some parameter on which battery is selecting for best performance

If power and speed are your top priorities, you will want a battery that can deliver high amounts of charge quickly and without overheating, so you’re looking for a high voltage and C rating.

Here is a summary of how each battery variable affects your performance:

#### Battery capacity

- Higher capacity is more the longer will be flight time but higher mass of the battery
- Increasing battery capacity will provide more flight time, but higher mass of the battery

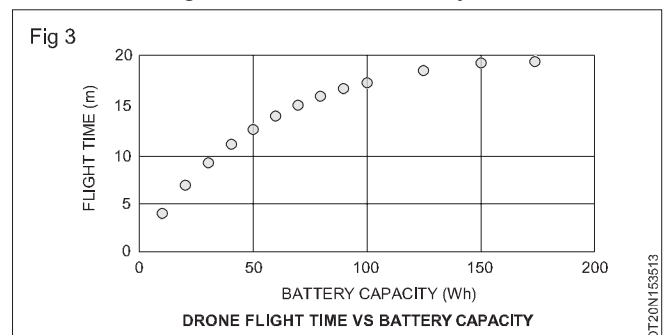

#### Voltage

- Higher voltage batteries will spin the motor at a higher RPM,
- Higher voltage batteries tend to be more efficient but also heavier

## Discharge/ C rating

- Select battery rating based on drone application - high speeds and quick delivery vs. constant low power
- If the discharge rate is too low, drone will lack power and underperform

- If the discharge rate is too high, it will be unnecessary weight

## Current draw

- Use the techniques mentioned to determine the current drawn by motors
- The battery should be able to provide at least as much current as the drone will draw to avoid overheating

## Example - the Right Battery for Maximum Flight Time

Parameter	A	B	C
Mass	6900g	7100g	6450g
Capacity	22,000mAh	20,000mAh	22,000mAh
C Rating	25C	65C	25C
Flight Time	31 mins	28 mins	34 mins

There are two main methods of charging batteries. They are;

- 1 Constant current battery charging
- 2 Constant voltage battery charging.

### 1 Constant current battery charging

In this method of charging batteries, the charging current supplied to the battery is kept at a prescribed (by the battery manufacturer) constant value. The amount of this constant current varies depending upon the Ah capacity of the battery. The value of constant charging current should not be excessive as this would cause excessive gassing. Excessive value current rises the cell temperature above the safe limit (generally 40°C) which will reduce the life of the battery.

Fig 4 shows a very simple method of constant current charging system.

In constant current charging, the output dc voltage of the charger will be generally twice the nominal voltage of the battery to be charged. But, the charging current is controlled by varying the rheostat connected in series with the battery. For example, to charge a 12 V battery, the dc voltage source can be 24 V, but the charging current will be kept controlled say, 1 ampere with the help of the rheostat.

With the introduction of voltage regulator integrated circuits like LM317, it has become very simple and less expensive to make constant current battery chargers. Fig 5 shows a simple constant current battery charger using LM317. This charger can be used for any type of battery charging as long as the charging current is less than 1.5 Amperes.

Current can be set at any value between 10 mA and 1.5 A in the circuit at Fig 5. To have higher currents, suitable external power transistors can be used. In Fig 5, the input voltage to the regulator IC (LM317) should be 1.5 times the battery voltage (to be charged) plus 3 V. LM317 used in Fig 5 is immune to output shorts or reverse battery connections. Hence, the charger will always be safe.

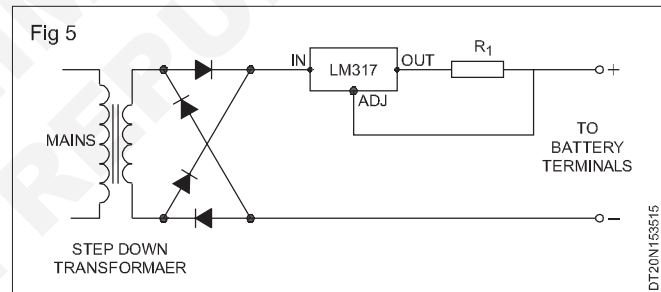
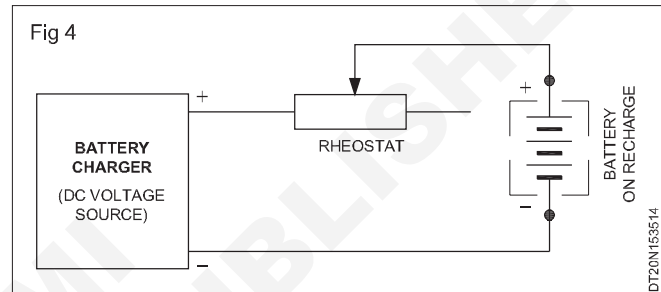

The disadvantage of constant current battery charging is that it takes comparatively long time to fully charge the battery. But, the charge efficiency, which is defined as, is high compared to constant voltage battery charging.

$$\text{Charge efficiency} = \frac{\text{Charge stored by the battery}}{\text{Charge supplied to the battery}}$$

### 2 Constant voltage battery charging

In this method, the voltage applied across the battery terminals is kept constant, but no control is imposed on the charging current. Therefore, the battery draws large charging current in the beginning and as the cells get charged, the charging current decreases to a small value.

In this method, the time required for charging is reduced to half compared to the constant current charging. But, the charge efficiency gets reduced by approximately 10%.

In constant voltage charging, the voltage applied to the cells for charging should be fixed at about 2.3 to 2.5 volt per cell and not more. For instance, for a 12 volts car battery, the dc voltage output of the charger should be between 14 V to 15 V.

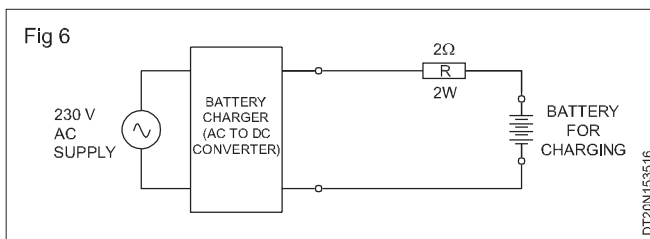

Simple constant voltage battery charging shown in Fig 6. Generally for converting AC into DC. Rectifier circuits are used. For precision operation, Thyristor based rectifiers also used.

Resistor R is used to limit the initial charging surge current from becoming excessively high. This is because excessive current may damage the diode and transformer of the battery charger unit.

**TRICKLE Charging:** Whenever a storage battery is used as an emergency reserve, as in the case of uninterrupted power supply (UPS), it is necessary to keep the batteries fully charged and ready for use at any time if the mains supply fails.

A fully charged battery, which is not connected to any load is expected to maintain its terminal voltage. But, due to internal leakage in the battery and other open circuit losses, the battery voltage slowly falls even in idle or open circuit condition. Therefore, to keep it in fully charged condition, the battery should be supplied with a charging current which is small and just sufficient to compensate the idle condition or open circuit losses. This small current charging is known as Trickle charging. Trickle charging keeps the battery always fully charged and in ready to use condition, so that, the battery can be fully made use of in emergency conditions.

### Building Blocks of Battery Management System

The design of the BMS is board is a bit complicated. To keep this article short and informative, we have briefly defined building blocks of the BMS as shown in Fig 7

There are four main functional blocks,

- Cut-off FETs
- Fuel Gauge Monitor
- Cell voltage monitor
- Temperature Monitor

#### 1 Cut-off FETs

A FET-driver acts as isolation between the battery and the charger. It is used to connect the low-side and high-side of the battery pack.

- Low-side – Activates NMOSFET without charge pump driver
- High-side – Activates NMOSFET using the charge pump driver

Integrated Cut-off FETs reduce the overall cost of the BMS. It is also eliminating the use of high voltage devices that could consume a large die area.

#### 2 Fuel Gauge Monitor

This helps in keeping track of the charge entering and exiting the battery pack. The charge flowing is calculated by multiplying current and time.

to measure the current flow, the most efficient and cost-effective method is to measure the voltage of sense resistor using a 16-bit ADC with low offset and high common-mode rating.

Higher ADC is beneficial to obtain an extensive dynamic range at more speed.

#### 3 Cell Voltage Sensors

Cell voltage monitoring useful in determining the health of the battery. All cells in a battery should operate at standard voltage levels during charging and discharging for safety and improving the lifecycle.

#### 4 Temperature Monitoring

As technology is evolving, batteries are made to supply high currents in the meantime keeping the voltage constant.

Batteries can unexpectedly explode due to a fast temperature rise produced by a high current flow. It must be prevented. Because of this, the BMS continually checks the battery's temperature and regulates it to the specified level.

Temperature Monitoring useful if the temperature rises above the rated value, it will inform you to start/stop charging or discharging.

#### 5 Other Building Blocks

other blocks that are available

- **Battery Authentication** – prevents the connection of BMS electronics to the third-party battery pack.
- **Real-time Clock (RTC)** – used in black-box application
- **Memory** – used in black-box application
- **Daisy Chain** – simplifies the connection between stacked devices

Fig 7

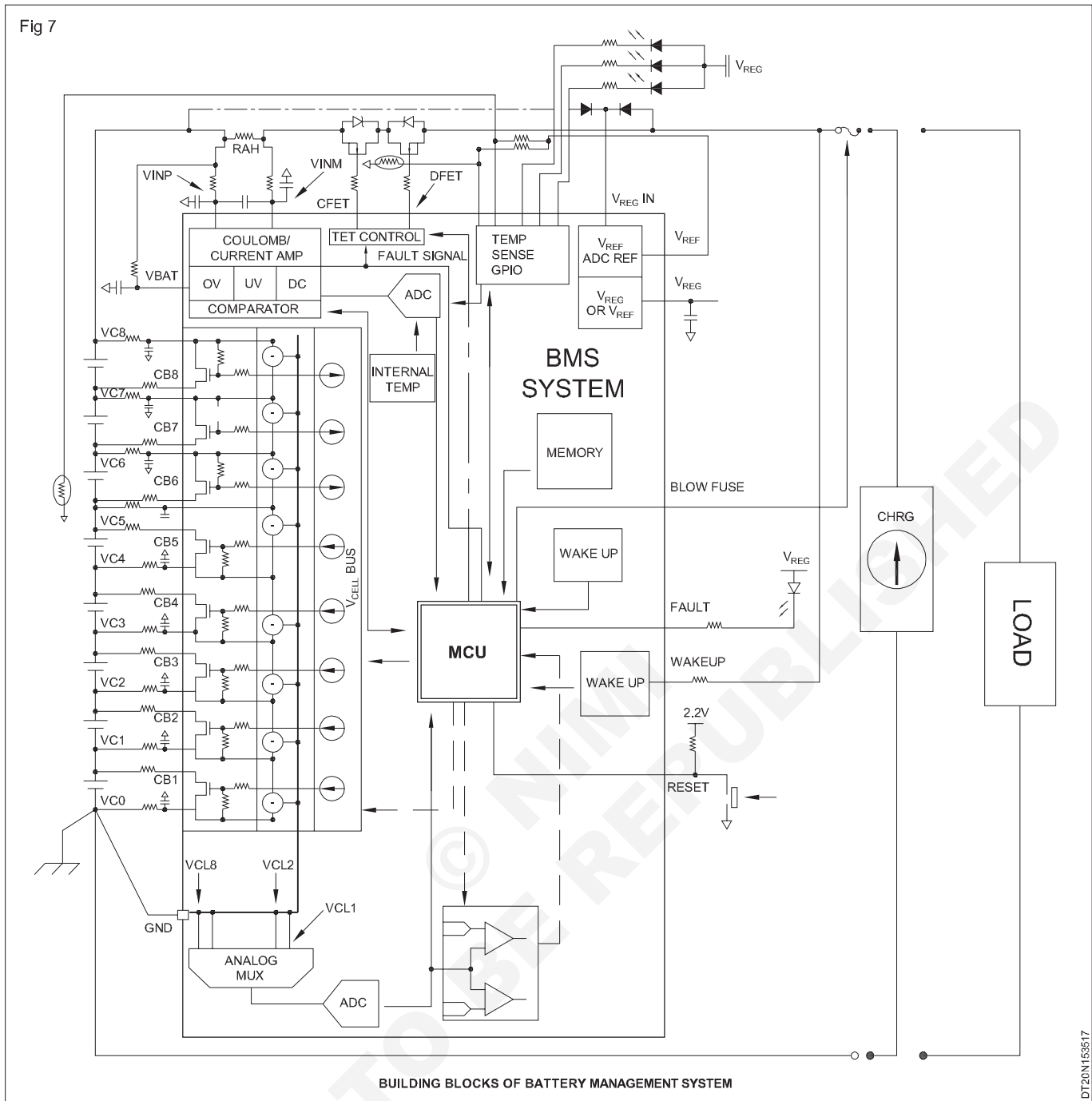

DT20N153517

**Explore of different sensors used in drone and their roles and characteristics**

**Objectives:** At the end of this lesson you shall be able to

- state the type of sensors used in drone
- explore the operation of sensor
- state sensors roles and their classification.

**Different Sensors Used in Drone**

**Accelerometer:-** Accelerometer defines the rate of changes in objects speed & provides information on whether it is going up or down it senses the static gravity acceleration & dynamic acceleration to find out motion type. The unit of measurement is  $m/s^2$  and  $g = 9.8 m/s^2$ . It defines acceleration in three- different areas x, y, z. it senses both linear motion & the earth's gravitational pull.

**Gyroscope:** - Gyroscope measures the "rate of object rotation" about its axis in RPM/degrees per second. Gyroscope aligned in such a way with its axis. It affords information on orientation of quadcopter on three-axis like roll, pitch and yaw are measured.

**Inertial Measurement Unit (IMU):-** IMU is used to measure the accurate value of orientation, velocity & quadcopter location. IMU is a board where it combines the acceleration with a gyrometer for greater stability. The errors in the gyroscope feed can be corrected with IMU it also contains a magnetometer.

- Gyroscopes – determine the rate of rotation, or angular velocity and tilt
- Accelerometers – determines linear movement along any axis
- Magnetometers – indicate the direction of the magnetic field to verify heading

**Barometer:-** Barometer is used to measure the atmospheric pressure in the air it's like a pressure sensor, which can calculate the altitude of a drone. If altitude increase, the pressure decreases.

**Magnetometer:** - Works like a compass to measure earth's magnetic field it corrects the drift of gyro provides contributory to the GPS.

**Tilt Sensors**

Tilt sensors is the combination of gyroscopes and accelerometers sensor, provide data to the flight-control board to maintain level flight. It detects small variations of movement.

**Principle of operation of various sensors used in drone**

**Role of Sensors in Drones****Core Sensors**

These sensors form the core part of drone and ensure its proper functioning and navigation. These sensors

are accelerometers, gyroscope, magnetic compass and barometer sensor.

**Important characteristics for sensors in drones**

Drones are subjective to extreme conditions including vibration, noise and environment. A sensor used in drone should have high shock survival capability, should capture less noise and fast enough to capture all vibration. Its performance should not vary with change in environment parameters such as temperature and humidity. And finally, it should consume ultra-low power to have enhanced battery life.

**Role of Algorithms**

Software libraries play an important role to convert raw sensor data into meaningful use case. The algorithm augments the function of sensor beyond their stated features. The algorithm also combines the input from various sensors and create a context aware output.

**Selection of appropriate sensor as per requirement****Sensors**

Sensors are devices that are frequently used to detect and respond to electrical or optical signals. A Sensor converts the physical parameter (for example: temperature, blood pressure, humidity, speed, etc.) into a signal which can be measured electrically. For example the temperature sensor. The mercury in the glass thermometer expands and contracts the liquid to convert the measured temperature which can be read by a viewer on the calibrated glass tube.

**Criteria to choose a Sensor**

There are certain features which have to be considered when we choose a sensor. They are as given below:

**1 Range:**

Difference between Maximum and Minimum value which can be sensed by the sensor. What is the minimum value you need to sense? What is the maximum value you need to sense?

**2 Resolution:**

The smallest change which can be sensed by the sensor. High is good but not always. If it is too high, it would pickup even very minute fluctuations which would then require additional processing.



### 3 Sensitivity:

Ratio of change in output to a unit change in the input. Again, high is good, but too high could be a problem. Also, higher the sensitivity, more will be the cost in most cases.

### 4 Error:

Difference between the Measured Value and True Value. You want this value to be low. All sensors have a margin of error. Does your application allow you to have that margin of error?

### 5 Accuracy:

It is inversely proportional to Error, i.e. How close the sensor reading is to the True Value. (Should be high).

### 6 Precision:

Ability to give/reproduce accurate value repeatedly. If a sensor is giving different values for the same physical conditions, it is not a good choice.

### 7 Response Time:

Time lag between the Input and Output. (Should be Minimum)

### 8 Signal-to-noise Ratio:

Ratio between the magnitude of the signal and the noise at the output.

### 9 Calibration:

As sensors need frequent calibration, so it should be easy to calibrate.

### 10 Cost: It shouldn't be expensive

**11 Nature of Output:** Do we need Analog output or Digital output, it should be clear.

### 12 Environment:

It is one of the most important parameters because not all sensors can work in extreme conditions. Sensors can get affected due to the non-ideal conditions (like temperature, humidity, etc.) which may affect the output of the sensor.

**13 Flexibility:** We check whether the sensor can adapt to changes in the product with a simple OTA.

**14 Interfacing:** It should be compatible to use with a wide range of instruments.

**15 Size and Weight:** Sensors should be compact and lightweight.

**16 Repeatability** - The reading that varies is repeatedly measured under the same environment

### Classification of Sensors

The sensors are classified into the following criteria:

- 1 Primary Input quantity
- 2 Transduction principles (Using physical and chemical effects)
- 3 Material and Technology
- 4 Property
- 5 Application

## Voltage-to-current & current-to-voltage converter using OP AMP

**Objectives:** At the end of this lesson you shall be able to

- explain voltage-to-current converter and current-to-voltage converter

### Voltage-to-current converter

Figure 1 shows a feedback circuit. Since the returning voltage opposes the input voltage the feedback is negative, from Fig 1.

$$I_{out} = V_{in} / R \dots\dots (1)$$

$$Z_{in} = \infty \dots\dots (2)$$

$$Z_{out} = \infty \dots\dots (3)$$

In a perfect voltage-to-current converter, the output current depends only on the input voltage and the value of R.

The infinite input impedance means the voltage-to-current converter will not load down the circuit driving it. Also, the infinite output impedance implies the circuit acts like a current source. A voltage-to-current converter has a high input impedance and a high output impedance. One of the applications of voltage-to-current converter is in building an electronic voltmeter.

### Application

In instrumentation most of transducers produce voltage easily, but current is not produced easily. So for converting voltage to current using OP-Amp based circuits.

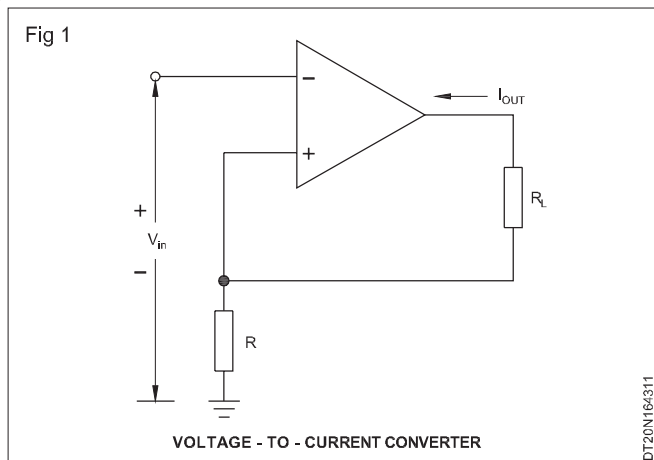

### Current to voltage converter

Figure 2 shows current-to-voltage converter of negative feedback. From Fig 2.

$$V_{out} = R \times I_{in} \dots\dots (1)$$

$$Z_{in} = \infty \dots\dots (2)$$

$$Z_{out} = 0 \dots\dots (3)$$

In a perfect current-to-voltage converter the output voltage depends only on the input current and the value of R.

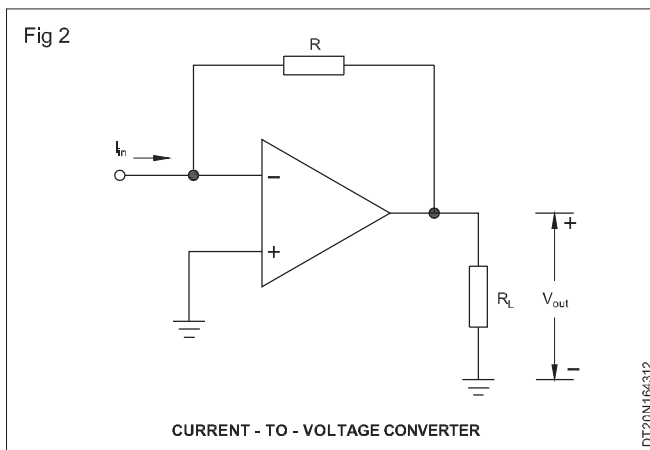

The zero input impedance means the converter looks like a perfect current sink (ground). A current-to-voltage converter will not load down the circuit driving it and also its output voltage is unaffected by small load resistance.

A current-to-voltage converter has a high input impedance and a low output impedance. One of the applications of the current-to-voltage converter is in building an electronic ammeter.

### Applications

The transmitter outputs are mostly in current. But where as the display systems are required voltage input for this purpose, current to voltage converters are using.

## Op-Amp Applications - differential & instrumentation amplifiers

**Objectives:** At the end of this lesson you shall be able to

- describe the working of differential amplifier
- describe the operation of instrumentation amplifier.

### Differential amplifier:

The easiest way to construct fully-differential circuit is to think of the inverting op-amp feedback topology. In fully differential op-amp circuits, there are two inverting feedback paths:

#### 1 Inverting input to noninverting output

#### 2 Non inverting input to inverting output

Both feedback paths must be closed for the fully - differential op-amp to operate properly.

The differential amplifier has a unique feature that many circuits don't have - two inputs. This circuit amplifies the difference between its input terminals. Other circuits with one input actually have another input – the ground potential. But, in cases where a signal source (like a sensor) has both of its terminals biased at several volts above ground, you need to amplify the difference between the terminals. What about noise that adds an unwanted voltage equally to both terminals of a sensor? The differential amplifier reject the noise and rescue the signal.

### A new pin

Fully-differential op-amps have an extra input pin (VCOM). The purpose of this pin is to provide a place to input a potentially noisy signal that will appear simultaneously on both inputs – i.e. common mode noise. The fully-differential op-amp can then reject the common mode noise.

The VCOM pin can be connected to a data converter reference voltage pin to achieve tight tracking between the op-amp common mode voltage and the data converter common mode voltage. In this application, the data converter also provides a free dc level conversion for single supply circuits. The common mode voltage of the data converter is also the dc operating point of the single-supply circuit. The designer should take care, however, that the dc operating point of the circuit is within the common mode range of the op-amp + and - inputs. This can most easily be achieved by summing a dc level into the inputs equal or close to the common mode voltage.

### Gain

A gain stage is a basic op-amp circuit. Nothing has really changed from the single-ended design, except that two feedback pathways have been closed. The differential gain is still  $R_f/R_{in}$  a familiar concept to analog designers. fig 1 shows the differential amplifier circuit.

This circuit can be converted to a single-ended input by connecting either of the signal inputs to ground. The gain equation remains unchanged, because the gain is the differential gain.

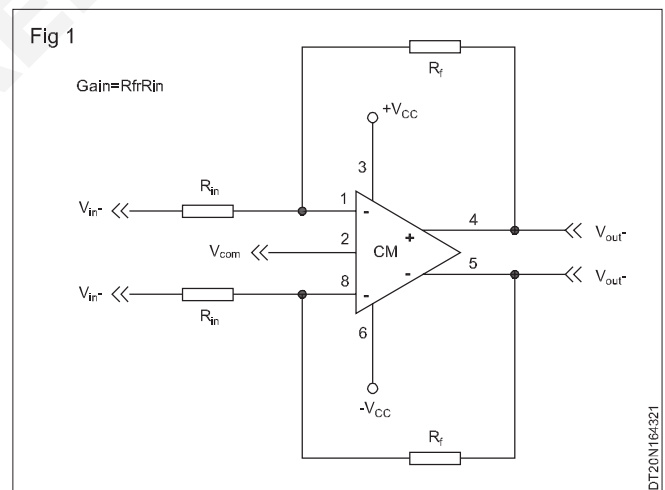

### Instrumentation amplifier:

An instrumentation system is used to measure the output signal produced by a transducer. The input stage is composed of a transducer, depending on the physical quantity to be measured.

The output stage may use devices such as meters, oscilloscopes and display circuits. The signal source of instrumentation amplifier is the output of the transducer. To amplify the low level output signal of the transducer, instrumentation amplifier is used in the middle. It is nothing but a differential amplifier using 3 op-amps and mainly used in instrumentation system.

Instrumentation amplifier is differential OP-Amp circuit which providing high input impedance with simple gain adjustment.

The differential input single-ended output instrumentation amplifier is one of the most versatile signal processing amplifiers available. It is used for precision amplification of differential dc or ac signals while rejecting large values of common mode noise. By using integrated circuits, a high level of performance is obtained at minimum cost. Fig.2 shows a basic instrumentation amplifier which provides a 10 volt output for 100 mV input, while rejecting common mode noise. To obtain good input characteristics, two voltage followers buffer the input signal. The LM102 is specifically designed for voltage follower usage and has 10,000 MW input impedance with 3 nA input currents. This high input impedance provides two benefits: it allows the instrumentation amplifier to be used with high source resistances and still have low error; and it allows the source resistances to be unbalanced by over 10,000X with no degradation in common mode rejection.

The followers drive a balanced differential amplifier, as shown in Fig 2, which provides gain and rejects the common mode voltage. The gain is set by the ratio of R4 to R2 and R5 to R3. With the values shown, the gain for differential signals is 100.

To obtain good common mode rejection ratios, it is necessary that the ratio of R4 to R2 match the ratio of R5 to R3. For example, if the resistors in circuit shown in Figure 1 had a total mismatch of 0.1%, the common mode rejection would be 60 dB times the closed loop gain, or 100 dB. The circuit shown in Fig 3 would have constant common mode rejection of 60 dB, independent of gain.

The important features of instrumentation amplifier are

- a High gain accuracy
- b High CMRR
- c Low dc offset
- d High input impedance
- e Low output impedance
- f Low noise

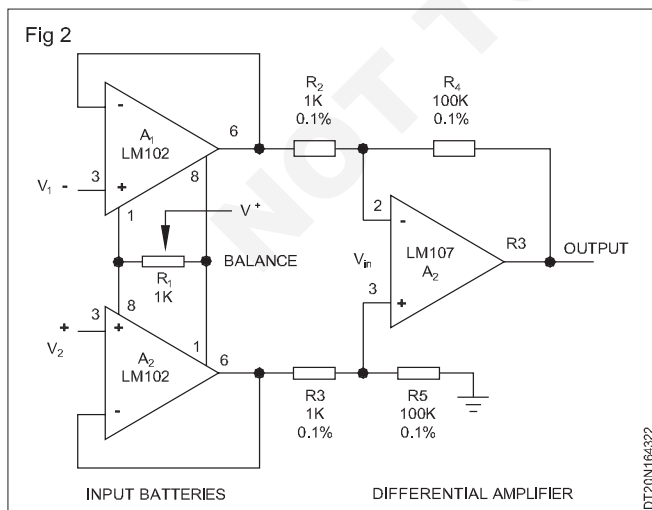

In either circuit, it is possible to trim any one of the resistors to obtain common mode rejection ratios in excess of 100 dB.

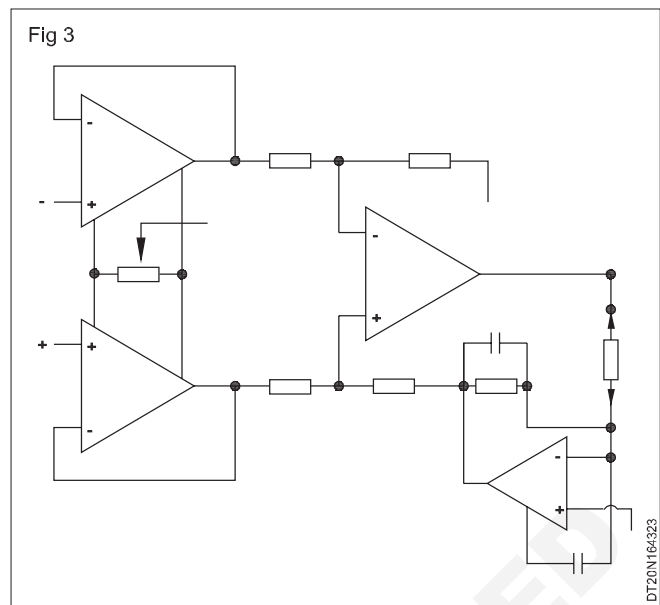

For optimum performance, several items should be considered during construction. R1 is used for zeroing the output. It should be a high resolution, mechanically stable potentiometer to avoid a zero shift from occurring with mechanical disturbances. Since there are several ICs operating in close proximity, the power supplies should be bypassed with 0.01 mF disc capacitors to insure stability. The resistors should be of the same type to have the same temperature coefficient.

A high I/P impedance instrumentation amplifier is shown below.

This circuit consisting two buffer circuits with '3' new resistors (R2,R1,R2) linking them. The gain of amplifier can change by simply adjusting 'R1' value.

If need variable gain, simply replace a 'R1' with potentiometer.

$$\text{Voltage gain (AV)} = \frac{V_o}{(V_1 - V_2)}$$

$$= \left(1 + \frac{2R_2}{R_1}\right) \times \frac{R_4}{R_3}$$

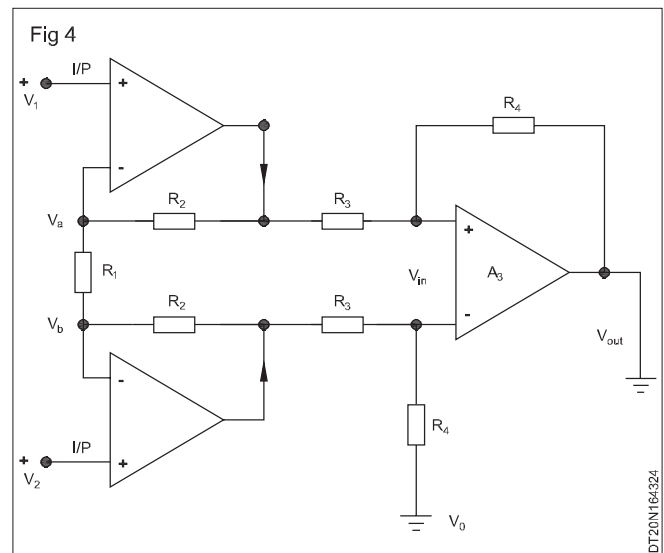

# Class A Power Amplifiers

**Objectives:** At the end of this lesson you shall be able to

- list the two main classifications of amplifiers
- list the classifications of amplifiers based on the amount of bias
- state the amount of biasing to be given for Class A amplifier
- list the disadvantages of Class A amplifiers
- list the applications of Class A amplifiers.

## Amplifier classification

In addition to the various classifications previous amplifiers can also be classified as,

- Voltage amplifiers
- Power amplifiers.

The amplifier circuits discussed in previous lessons were small signal voltage amplifiers. This means these amplifiers are intended to amplify very weak signals in the range of  $\mu$  volts to millivolts. These amplifiers were concerned with increasing the weak signal voltage into a few volts. But the output of such amplifiers cannot be used to operate devices such as loudspeakers.

In order to operate loudspeakers, in addition to voltage amplifiers, amplifiers known as Power amplifiers are required. A power amplifier is essentially a current amplifier. A power amplifier may or may not provide any significant voltage gain. Fig 1 illustrates voltage and power amplifiers.

An easy way of identifying whether an amplifier is a voltage amplifier (small signal amplifier) or a power amplifier is by checking the type of transistors used in the amplifier. This is shown in Fig 1.

Another method of classifying amplifiers is based on the amount of DC bias given to the amplifier in its quiescent state. Based on this the amplifiers may be mainly classified as,

- Class A amplifiers
- Class B amplifiers

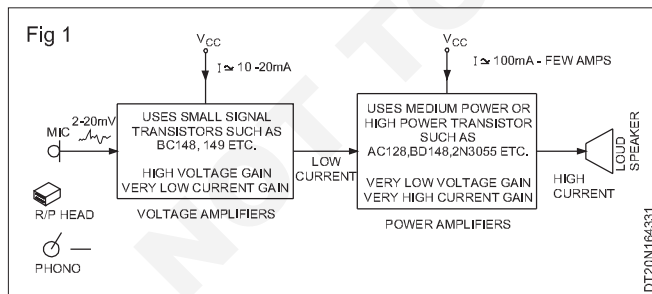

- Class C amplifiers.

## Class A amplifiers

An amplifier is said to be operating as a Class A amplifier if the amplifier is active and current are flowing through the different paths of the amplifier even when no ac signal is fed to it for amplification.

The above statement means that the transistor of the amplifier is operating in the active region at all times whether or not the input ac signal is present.

To ensure that the transistor is always in active region, suitable dc biasing arrangement is necessary. Fig 2a shows a transistor amplifier with dc biasing such that it works in Class-A mode (always active) of operation.

In the CE amplifier of Fig 2, an ac voltage  $V_{in}$  drives the base, producing an ac output voltage  $V_{out}$ .

The biasing arrangement and the dc load line of the CE amplifier at Fig 2 is below;

$$I_{C(sat)} = \frac{V_{CC}}{R_C + R_E} = \frac{9}{820 + 180} = 9\text{mA}$$

$$V_B = \frac{R_2}{R_1 + R_2} \cdot V_{CC} = \frac{10\text{K}\Omega}{57\text{K}\Omega} \cdot 9\text{V} = 1.58\text{V}$$

$$I_{EQ} = \frac{V_B - V_{BE}}{R_E} = \frac{1.58\text{V} - 0.7\text{V}}{180\Omega} \approx 5\text{mA}$$

$$V_{CEQ} = V_{CC} - (I_{CQ} \cdot R_C + I_{CQ} \cdot R_E) = 9 - (4.1 + 0.9) = 4 \text{ volts.}$$

From the above values the DC load line is drawn in Fig 2b.

## Loaded voltage gain ( $A_{VL}$ )

The unload gain (with  $R_L$  open) of the amplifier is given by

When load  $R_L$  is connected, then the resistance seen by the collector of transistor (call it  $r_{out}$ ) is given by,

$$r_{out} = R_C \parallel R_L$$

In Fig 2,

$$r_{out} = 820\Omega \parallel 1500\Omega = 530\Omega$$

Therefore, the loaded voltage gain is given by,

$$A = \frac{r_{out}}{r_e}$$

$$r_e = \frac{25\text{mV}}{I_{EQ}} = \frac{25\text{mV}}{5\text{mA}} = 5\Omega$$

Therefore in Fig 2, loaded voltage gain is,

$$A_{VL} = \frac{530\Omega}{5\Omega} = 106$$

## Current gain ( $A_i$ )

Current gain of the transistor  $A_i$  is,

$$A_i = \frac{i_c}{i_b} \approx \beta_{dc} \approx 10 \text{ of the transistor}$$

In Fig 2,

**Power gain (Ap)**

In Fig 2, the ac input power to the base is,

$$P_{in} = V_{in} \cdot i_b$$

The ac output power from the collector is,

$$P_{out} = -V_{out} \cdot i_c$$

The power gain (Ap) of the amplifier is,

$$A_p = A_v \cdot A_i$$

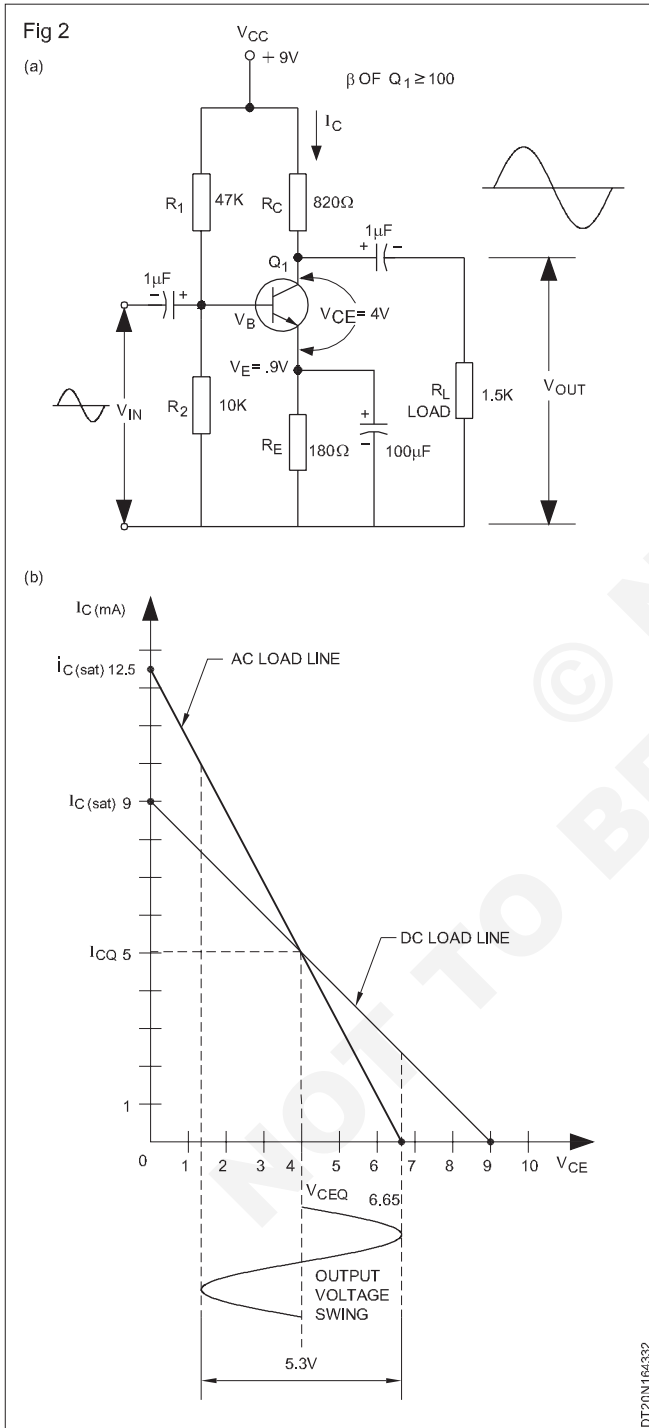

In Fig 2,  $A_p = A_v \cdot A_i = (106) (100) = 10,600$

This means that an ac input power of 1μ watt results in an ac output power of 10,600μ watts or 10.6m watt.

**Load power**

In Fig 2, the ac power into the load resistor RL is given by,

$$P_L = \frac{V_L^2}{R_L}$$

where,

$P_L$  = AC load power

$V_L$  = rms load voltage

$R_L$  = load resistance

Since  $V_{L(rms)} = 0.707 V_p$

and

Therefore, VL2 can be written as  $V_P = \frac{V_{pp}^2}{8}$

Hence, ac power into the load PL can be written as,

$$\frac{V_{pp}^2}{8R_L}$$

This is the maximum ac load power that a class A amplifier can produce without output distortion or clipping.

**AC load line**

The saturation and cut-off points of ac load line are different from those of dc line.

The ac saturation current  $i_{c(sat)}$  is given by,

For Fig 2,

$$i_{c(sat)} = 5mA + = 12.5mA$$

The AC cut-off voltage  $V_{ce}$  is given by,

$$V_{ce} = V_{CEQ} + I_{CQ} V_{out}$$

For Fig 2,

$$V_{ce} = 4V + (5mA \cdot 530\Omega) = 6.65 \text{ volts.}$$

These values of  $i_{c(sat)}$  and  $V_{ce}$  are plotted on Fig 2b to get the ac load line.

**AC output compliance**

The ac output compliance is the maximum unclipped peak-to-peak ac voltage that an amplifier can produce. This ac output compliance can be obtained by drawing Dc and ac load lines.

As can be seen in Fig 2b, the ac compliance is,

$$\begin{aligned} &\text{AC compliance (peak-to-peak)} \\ &= (V_{ce} - V_{CEQ}) \times 2 = (6.65 - 4) \times 2 \\ &= 5.3 \text{ volts (peak-to-peak)} \end{aligned}$$



### Maximum ac load power

The ac output compliance (peak-to-peak) equals the maximum unclipped voltage, therefore, maximum ac load power  $P_L$  is given by,

For the circuit at Fig 2.

### Transistor power dissipation

When there is no input signal, transistor is still in conduction in Class-A amplifier hence power is dissipated. This power  $P_Q$  is given by,

$$P_Q = V_{CEQ} \cdot I_Q$$

For Fig 2,

$$P_Q = (4V)(5mA) = 20mW$$

The DC current drawn by the biasing resistor  $R_1$  and  $R_2$  is

$$I_1 = \frac{V_{CC}}{R_1 + R_2} = \frac{9V}{47K + 10K} = \frac{9}{57K} = 158\mu A \text{ or } 0.16mA$$

The DC current through the collector in quiescent state is  $I_{CEQ}$ ,

In Fig 2,  $I_{CEQ} = 5mA$

Therefore the total current drawn in quiescent state is,

$$I_{TQ} = I_{CQ} + I_1 = 5mA + 0.16mA = 5.16mA$$

The power input to the amplifier in quiescent state is

$$P_{TQ} = I_{TQ} \cdot V_{CC} = (5.16mA)(9V) = 46mW$$

### Efficiency of class A amplifier stage

$$P_{L(max)} = \frac{[\text{Output compliance (peak-to-peak)}]^2}{8R_L}$$

where,

$$\eta = \text{state efficiency}$$

$$P_{L(max)} = \text{maximum ac load power}$$

$$P_{TQ} = \text{Dc input power}$$

For Fig 2,

$$P_{L(max)} = 2.34mW \text{ and } P_{TQ} = 46mW$$

Therefore, efficiency of the amplifier stage is,

From the above calculation the efficiency of the Class-A amplifier is only 5%. This low efficiency is the main disadvantage of Class-A amplifiers. With even best design

$$\eta = \frac{P_{L(max)}}{P_{TQ}} \times 100\% = \frac{2.34mW}{46mW} \times 100 = 5\%$$

it is only possible to get an efficiency of less than 30% in Class-A amplifiers. But this disadvantage is compensated in Class-A by the quality of undistorted amplified output. Typical value of distortion in Class-A amplifiers is less than 5%.

### Application of Class A amplifiers

Due to the advantage of minimum distortion, Class A amplifiers are used as the first amplifier stage to amplify weak signals coming out of devices like microphones, play head of tape recorders etc. If the first stage is not providing minimum distortion, the distortion gets amplified in further stages and makes the sound garbled. Hence, Class A is the most common way of making transistors work in Linear circuits because these circuits lead to the simplest and most stable biasing circuits.

Many Class A amplifiers use fixed-bias because of its inherent advantage that the transistors will never go to saturation and hence, distortion is minimised. Class A amplifiers with transformer coupling are sometimes used as power-amplifier stage in which case stage efficiency up to 50% can be obtained.

## How to calibrate Compass sensor, Lidar Sensor, Gyro sensor

**Objectives:** At the end of this exercise you shall be able to

- calibrate the compass
- calibrate Lidar
- calibrate gyro sensor.

### Calibrate Compass sensor

Go to Compass and click on Live Calibration for starting calibration.

Fig 1





Fig 2



Fig 6



Start Rotating Drone

Fig 3



Fig 7



Fig 8

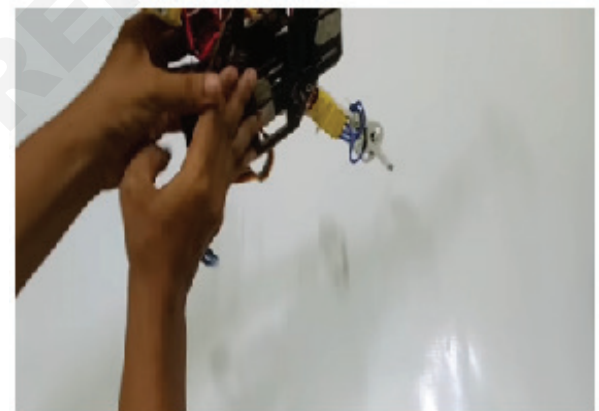

Fig 4



Put the drone Nose Up and rotate the drone 360°, do same for right side

Fig 5



Fig 9



## Calibrate Lidar Calibration

- 1 Connect the LiDAR
- 2 Connect the camera
- 3 Collect the photo and LiDAR data
- 4 Calibration data acquisition

## Gyroscope Calibration

- 1 Click the Gyroscope sensor button
- 2 Place the vehicle on a surface and leave it still.
- 3 Click Ok to start the calibration.
- 4 Place the drone in flat plate
- 5 Follow the instruction which is coming on screen
- 6 Once the calibration is complete a green colour light will blink.
- 7 Software will display Calibration complete

Concept of sensor calibration and using sensors in digital & analog mode.

### What is Sensor Calibration?

Sensors are electronic devices. They are sensitive to the changes in their working environment. Undesirable and sudden changes in the working environments of the sensors give undesired output values. Thus, the expected output differs from the measured output. This comparison between the Expected output and measured output is called Sensor Calibration.

Sensor calibration plays a crucial role in increasing the performance of the sensor. It is used to measure the Structural errors caused by sensors. The difference between the expected value and the measured value of the sensor is known as the Structural Error.

## Analogue and Digital Sensors

### Analogue Sensors

Analogue Sensors produce a continuous output signal or voltage which is generally proportional to the quantity being measured. Physical quantities such as Temperature, Speed, Pressure, Displacement, Strain etc are all analogue quantities as they tend to be continuous in nature. For example, the temperature of a liquid can be measured using a thermometer or thermocouple which continuously responds to temperature changes as the liquid is heated up or cooled down as shown in Fig 10. Thermocouple used to produce an Analogue Signal Analogue sensors tend to produce output signals that are changing smoothly and continuously over time. These signals tend to be very small in value from a few

microvolts ( $\mu\text{V}$ ) to several milli-volts ( $\text{mV}$ ), so some form of amplification is required. Then circuits which measure analogue signals usually have a slow response and/or low accuracy. Also analogue signals can be easily converted into digital type signals for use in microcontroller systems by the use of analogue-to-digital converters (ADCs).

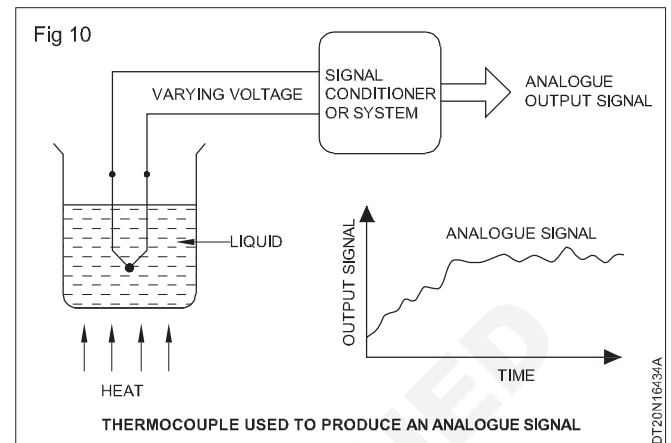

### Digital Sensors

As its name implies, Digital Sensors produce a discrete digital output signals or voltages that are a digital representation of the quantity being measured. Digital sensors produce a Binary output signal in the form of a logic "1" or a logic "0", ("ON" or "OFF"). This means then that a digital signal only produces discrete (noncontinuous) values which may be outputted as a single "bit", (serial transmission) or by combining the bits to produce a single "byte" output (parallel transmission). Light Sensor used to produce an Digital Signal In our simple example as shown Fig 11 the speed of the rotating shaft is measured by using a digital LED/Optodetector sensor. The disc which is fixed to a rotating shaft (for example, from a motor or robot wheels), has a number of transparent slots within its design, As the disc rotates with the speed of the shaft, each slot passes by the sensor in turn producing an output pulse representing a logic "1" or logic "0" level.

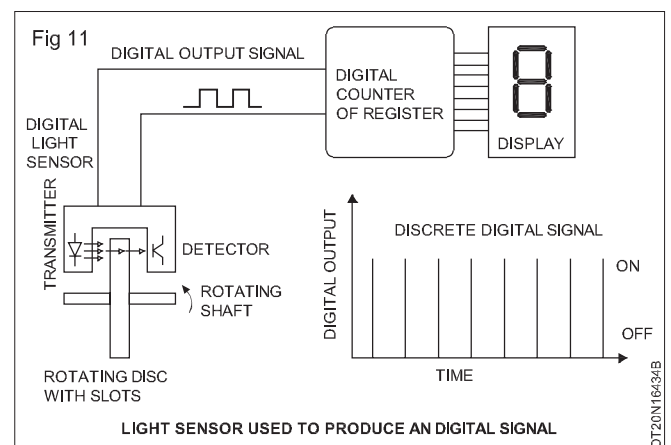

## Explore different motors and its functioning

**Objectives:** At the end of this lesson you shall be able to

- explore the different motors
- state the functions of Motors
- state the speed torque graph
- state the degree of freedom.

### Introduction to different motors

Introduction: A DC motor is a machine which converts DC Power energy into mechanical energy. It is similar to a DC generator in construction. Therefore, a DC machine can be used as a generator or as a motor. Even today, because of the excellent torque, speed and load characteristics of DC motors, 90% of the motors used in precision machines, wire drawing industry and traction are of this type. The DC motor needs frequent care and maintenance by qualified electricians. Hence more job opportunities exist in this area for an electrician.

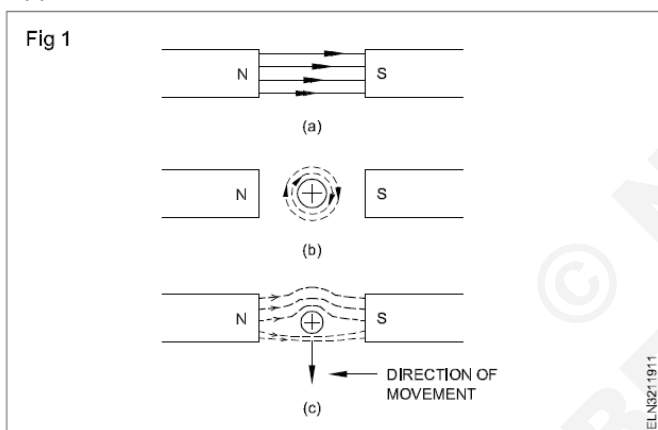

**Principles of a DC motor:** It works on the principle that whenever a current-carrying conductor is kept in a uniform magnetic field, a force will be set up on the conductor so as to move it at right angles to the magnetic field. It can be explained as follows. Fig 1a shows the uniform magnetic field produced by a magnet, whereas Fig 1b shows the magnetic field produced around the current-carrying conductor. Combining the effects of Fig 1a and Fig 1b in one figure, Fig 1c shows the resultant field produced by the flux of the magnet and the flux of the current-carrying conductor. Due to the interactions of these two fields, the flux above the conductor will be increased and the flux below the conductor is decreased as represented in Fig 1c. The increased flux above the conductor takes a curved path thus producing a force on the conductor to move it downwards.

If the conductor in Fig 1 is replaced by a loop of wire as shown in Fig 2, the resultant field makes one side of the conductor move upwards and the other side move downwards. It forms a twisting torque over the conductors, and they tend to rotate, if they are free to rotate. But in a practical motor, there are a number of

such conductors/ coils. Fig 3 shows the part of a motor. When its armature and field are supplied with current, the armature experiences a force tending to rotate in an anticlockwise direction as shown in Fig 3.

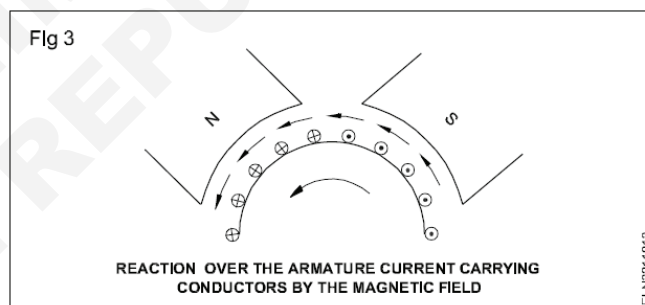
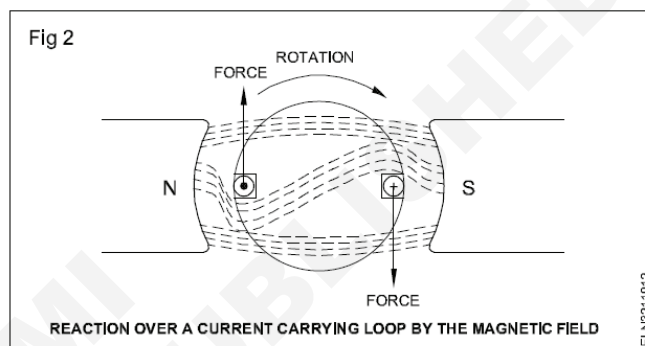

The direction of rotation or movement can be determined by Fleming's left hand rule. Accordingly, the direction of rotation of the armature could be changed either by changing the direction of armature current or the polarity of the field.

**Fleming's Left Hand Rule:** The direction of force produced on a current-carrying conductor placed in a magnetic field

can be determined by this rule. As shown in Fig 4a, hold the thumb, forefinger and middle finger of the left hand mutually at right angles to each other, such that the forefinger is in the direction of flux, and the middle finger is in the direction of current flow in the conductor; then the thumb indicates the direction of motion of the conductor. For example, a loop of coil carrying current, when placed under north and south poles as shown in Fig 4b, rotates in an anticlockwise direction.

### BLDC

#### Why BLDC ?

The brushes in conventional D.C. Motors wear out over the

time and may cause sparking. As a result the conventional D.C. motors require occasional maintenance. Controlling the brush sparking in them is also a difficult affair. Thus the brushed D.C. motor should never be used for operations that demand long life and reliability. BLDC motors are used in most of the modern devices. Efficiency of the BLDC motor is typically around 85-90% whereas the conventional brushed motors are only 75-80% efficient. BLDC motors are also suitable for high speed applications (10000 rpm or above). The BLDC motors are also well known for their better speed control.

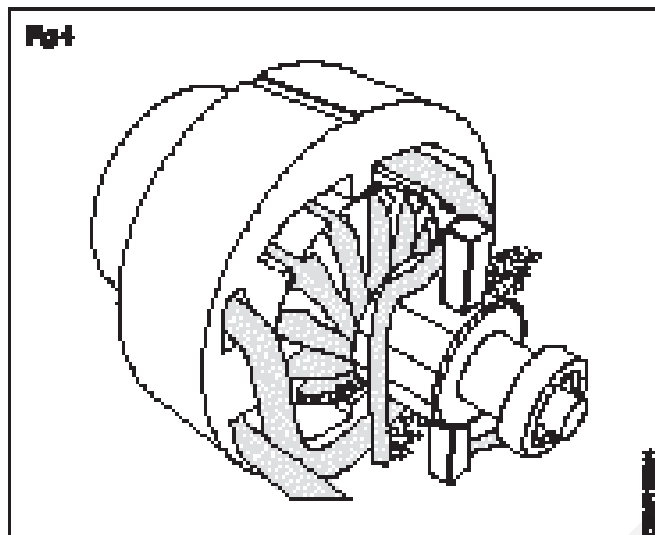

**Construction**

The rotor of a BLDC motor is a permanent magnet. The Stator has a coil arrangement.

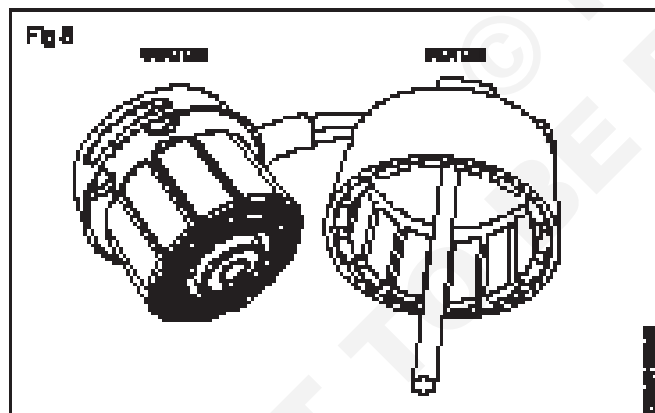

**Stator**

The Stator has a coil arrangement. These windings can be arranged in either star or delta

The Stator must be chosen with the correct rating of the voltage depending on the power supply capability. For robotics, automotive and small actuating applications. 48V or less voltage BLDC motors are preferred. For industrial applications and automation systems. 100 V or higher rating motors are used.

**Rotor**

BLDC motor incorporates a permanent magnet in the rotor. The number of poles in the rotor can vary from 2 to 8 pole pairs with alternate south and north poles depending on the application requirement. In order to achieve maximum

torque in the motor, the flux density of the material should be high. A proper magnetic material for the rotor is needed to produce required magnetic field density.

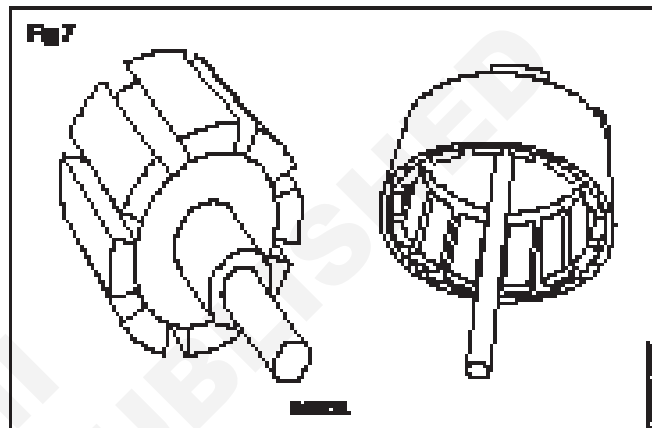
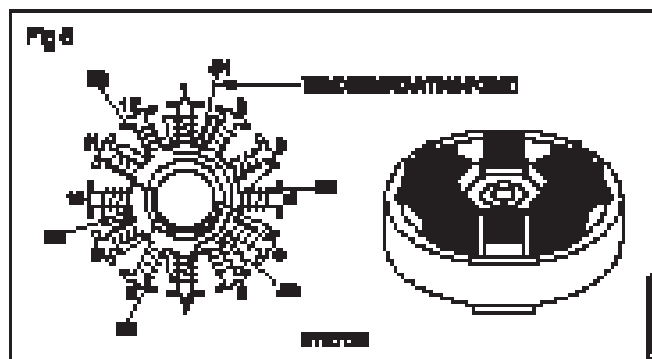

**Operation of BLDC**

By applying DC power to the coil, the coil will energize and become an electro magnet.

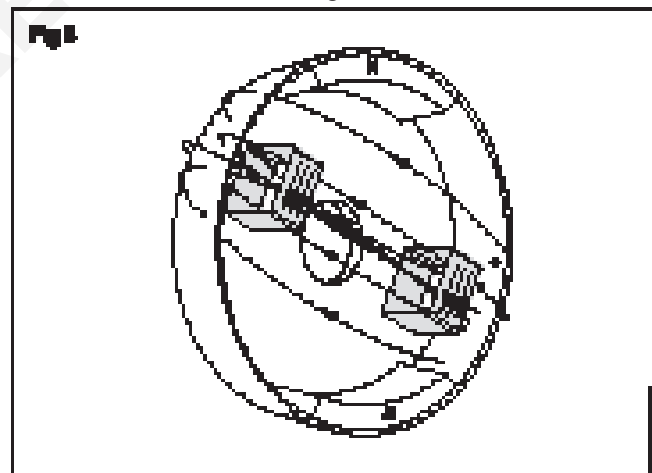

The operation of the BLDC is based on the simple force interaction between the permanent magnet and the electromagnet. In this condition, when the coil A is energized, the opposite poles of the rotor and stator are attracted to each other (The attractive force is shown in green arrow.). As a result the rotor poles move near to the energized stator.

**Servo motor**

Servo motors are an electric device that rotate or push parts of a machine with great accuracy. In a drone, servo motors move wing control surfaces.

Servos have three basic types: positional rotation, continuous rotation, and linear.



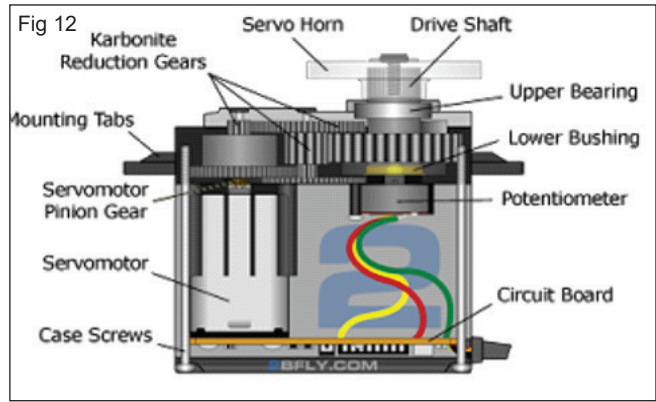
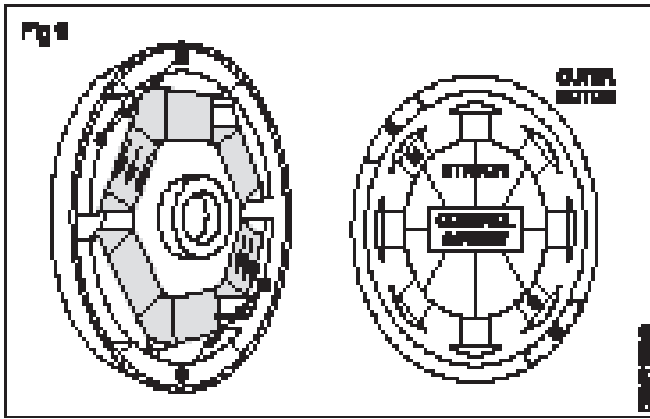

**Studying BLDC motor using PWM techniques**

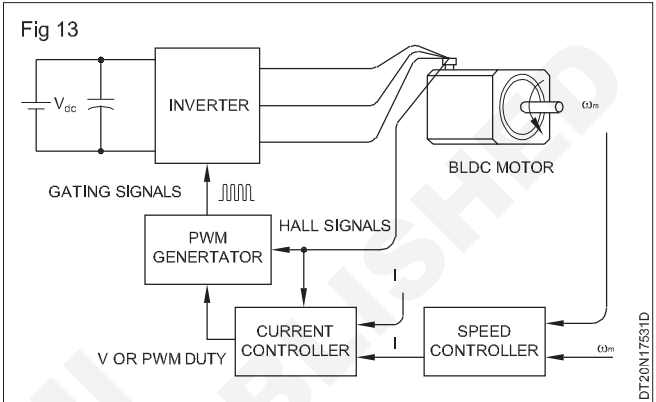
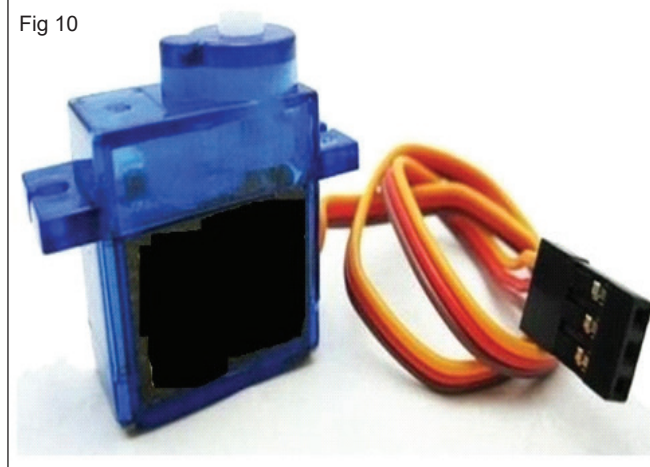

**Servo motor work**

The working of a servo is reliable. The servo working on the small direct current, spin at high RPM (rotations per minute) but put out very low torque. An arrangement of gears takes the high speed of the motor and slows it down and also increasing the torque.

work = force x distance

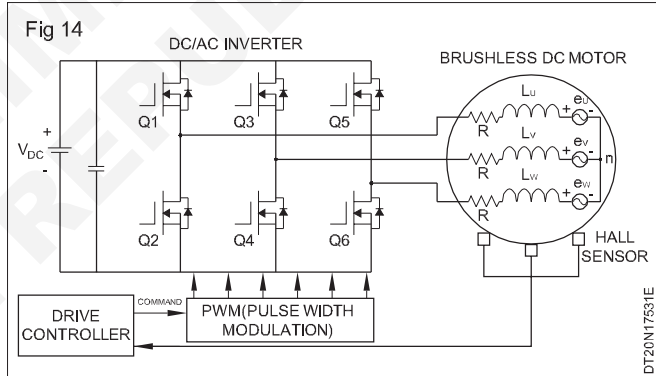
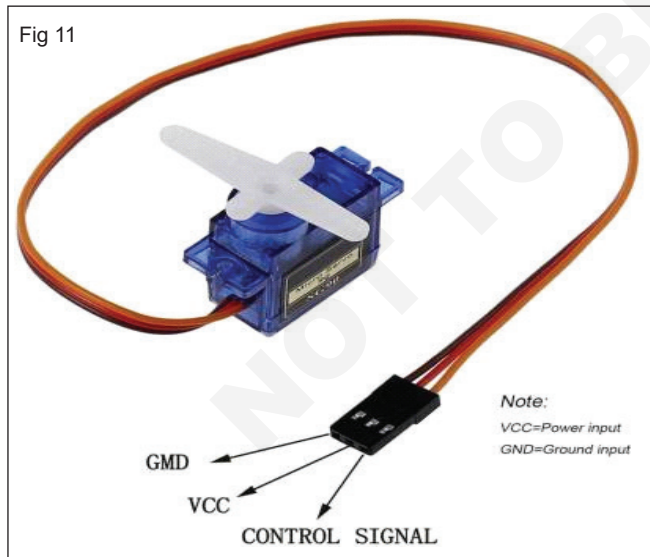

The most energy-intensive technique of controlling an analogue system with a processor's digital output is PWM technology. PWM has been generally used in power converter control.

**Speed Torque Curve for DC, BLDC and Servo motor**

Speed-torque characteristics: Figure shows the speed torque characteristic of a DC, Bldc and servo motor. It shows that the variation of torque with the speed.

**Degree of Freedom**

The quadcopter has 6 degree of freedom. This means that 6 variables are needed to express its position and orientation in space (x, y, z, φ, θ and ψ).

The x, y and z variables represent the distances of quadcopter's center of mass along the x, y and z axes respectively from fixed reference frame.

The other three variables are the three Euler angles which represent the quadcopter orientation.

(φ) is the angle about the x axis and is called roll angle

(θ) is the angle about y axis and is called pitch angle

(ψ) is the angle about z axis and is called yaw angle.

Fig 15

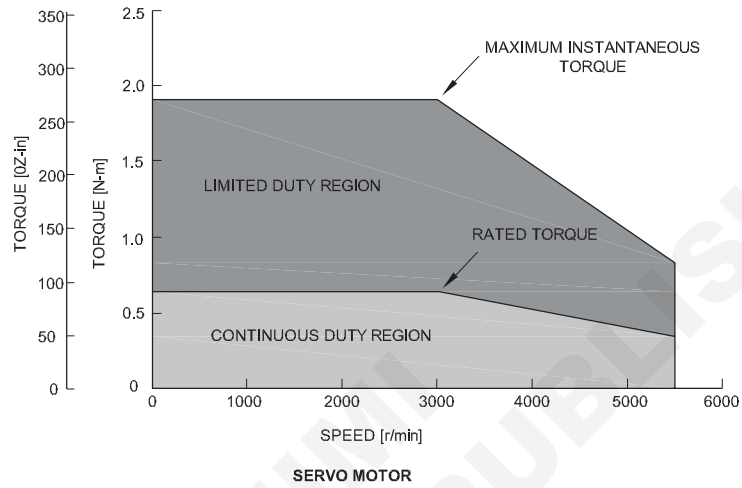
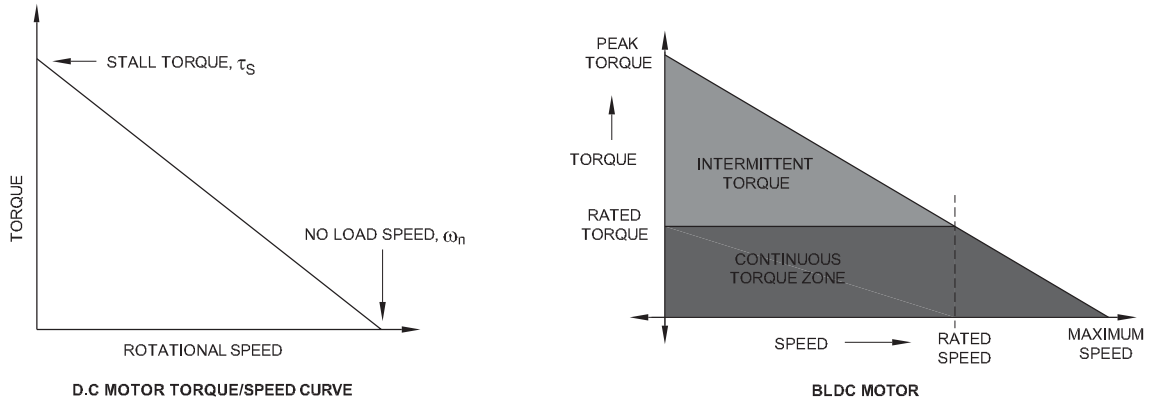

DT20N17531F

Fig 16

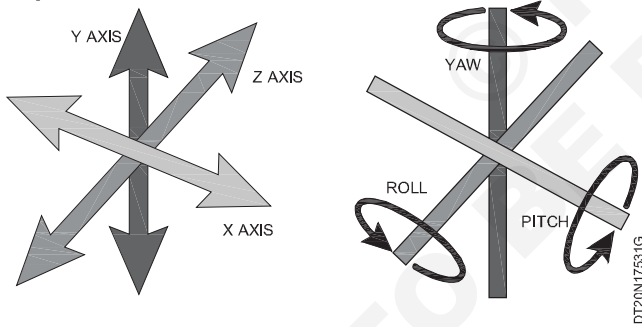
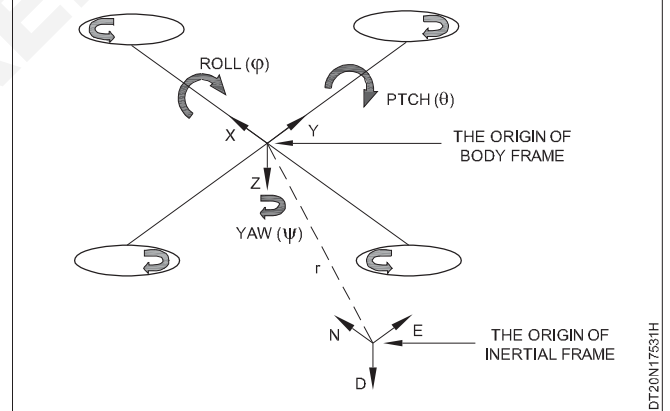

Fig 17



### Explain mathematical calculations

**Objective:** At the end of this lesson you shall be able to

- calculation of payload
- calculation of thrust to weight ratio
- state the inverted pendulum
- state the motor control by encoder counter.

### Performing mathematical calculations

#### payload calculation

Formula to calculate Payload

$$\text{Payload} = \text{AUW} - \text{Drone weight.}$$

Use the formula and calculate other payload possibility which drone can carry



S.No.	AUW	Drone Weight	Payload
1	4 kg	3kg	1kg
2	5 kg	3kg	2kg
3	6 kg	4kg	2kg
4	8 kg	5 kg	3 kg

### Speed control techniques

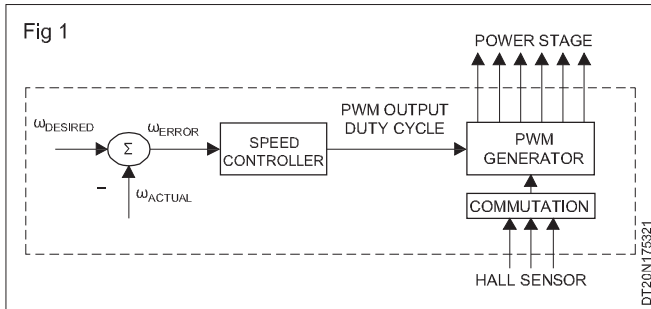

proper rotor rotation of the BLDC motor, while the motor speed depends only on the amplitude of the applied voltage. This amplitude is changed by the PWM technique. The required speed is controlled by a speed controller, implemented as a conventional PI controller. The PI controller compares the actual speed to the required speed and, using the difference, calculates duty cycle with the voltage amplitude required to correct the discrepancy.

### Thrust to weight ratio

Determine the optimal thrust of the drone motor the most important parameter is the thrust to weight ratio.

$$\frac{\text{Weight}}{\text{Thrust}} = \frac{1}{2.5} \text{ Kg}$$

S.No	Thrust	weight
1	8 kg	3.2kg
2	7kg	2.8kg
3	5kg	2kg
4	30Kg	12kg
5	25kg	10kg
6	15kg	6kg

### Introduction of Inverted Pendulum

An inverted pendulum is a pendulum with its centre of gravity above its pivot point. Unlike a normal pendulum, inverted pendulum is unstable and would fall down without any external applied force. It needs constant external force to keep it in upright position.

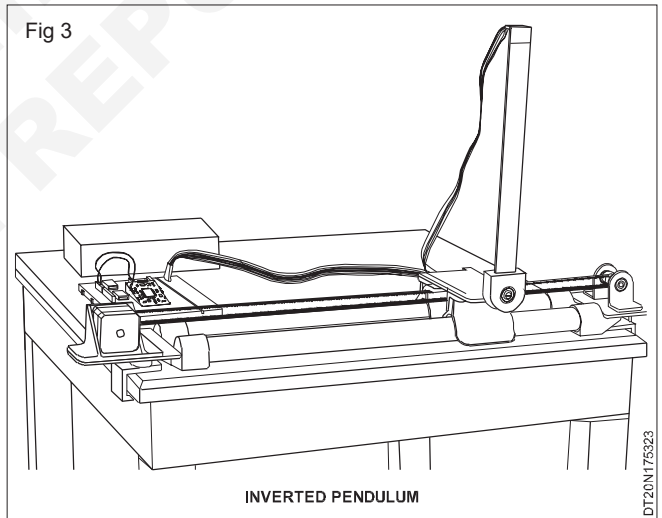
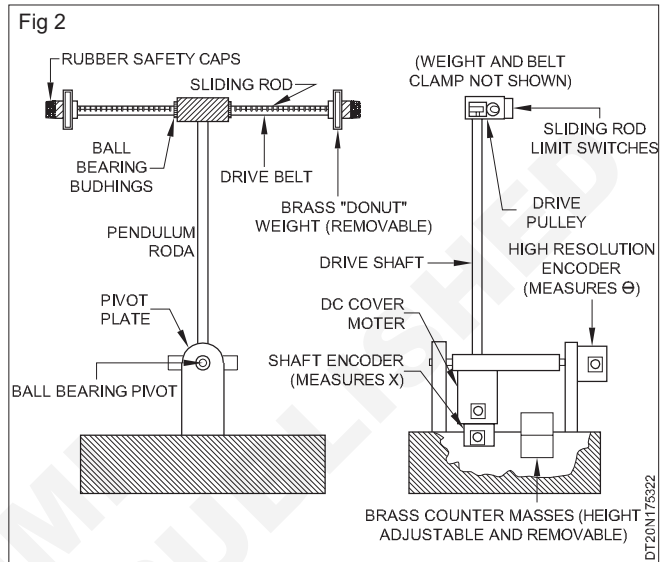

### PID control

PID stands for proportional integral derivative and it is a device used to control different process variables like pressure, flow, temperature, and speed in industrial applications. In this controller, a control loop feedback device is used to regulate all the process variables.

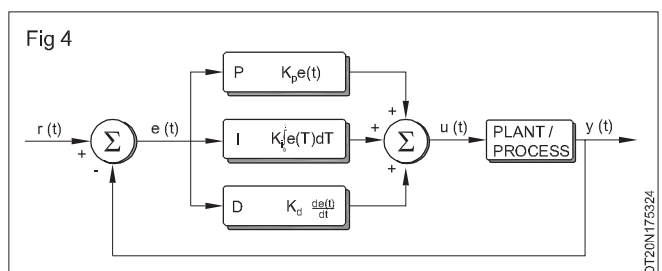

This type of control is used to drive a system in the direction of an objective location otherwise level. In this controller, closed-loop feedback is used to maintain the real output from a method like close to the objective otherwise output at the fixe point if possible.

### Motor control by Encoder counter

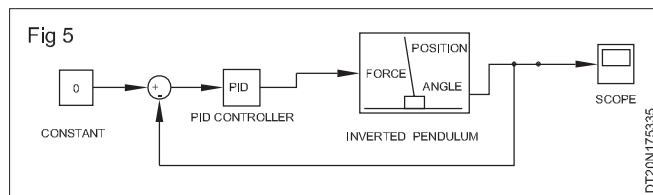

ADC motor's speed is inversely correlated with its voltage supply. An average voltage is produced when applying digital control via a pulse-width modulated (PWM) signal. As a result of the motor winding's function as a low pass

filter, a PWM waveform with a high enough frequency will produce a steady current in the winding. Even though speed and PWM duty cycle are inversely related, systems that need precise speed control must include a feedback mechanism. Position measurements in control systems are frequently provided by optical incremental encoders at predetermined sampling rates. To adjust the DC motor speed in reaction to load disturbances and noise, encoder feedback can be utilised in conjunction with a PID controller. The PID controller may rectify present mistake by proportional action, reduce steady-state offsets through derivative action, and anticipate the future through integral action. In a DC motor speed control system, a PID controller's goals are to keep speed at a specified reference value and have the flexibility to accept new set point values dynamically.

**Different types of antennas used for drones**

**Objectives:** At the end of this lesson you shall be able to

- state the antenna used in drone
- design of antenna radiation pattern and directivity
- state the mic amplifier and different filter used in RF range.

**Various types of antennas used for drones and their characteristics**

There are several different types of antennas in three broad categories:

- Omni-directional
  - Directional
  - Semi-directional
- Omni-directional antennas propagate in all directions.
  - Semi-directional antennas propagate in a constricted fashion, works in specific angle.
  - Directional antennas have a narrow “beam” that allows highly directional propagation; familiar types are the parabolic and Yagi.

**Directional antenna**

Directional antennas focus on radiated power into narrow beams, adding a significant amount of gain in the process. A directional antenna is a radio-frequency (RF) wireless antenna designed to function more effectively in some directions than in others. The directionality is improving transmission and reducing interference and reception of communications

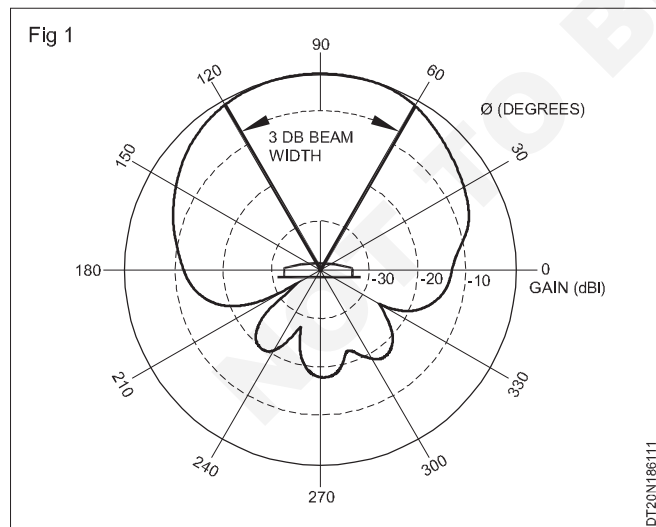

**Patch antenna, microstrip antenna**

A patch antenna is a semi-directional radiator is also known as a microstrip antenna which is using a flat metal strip mounted above a ground plane. Radiation from the back of the antenna is effectively cut off by the ground plane, enhancing forward directionality. It is typically rectangular and enclosed in a plastic enclosure.

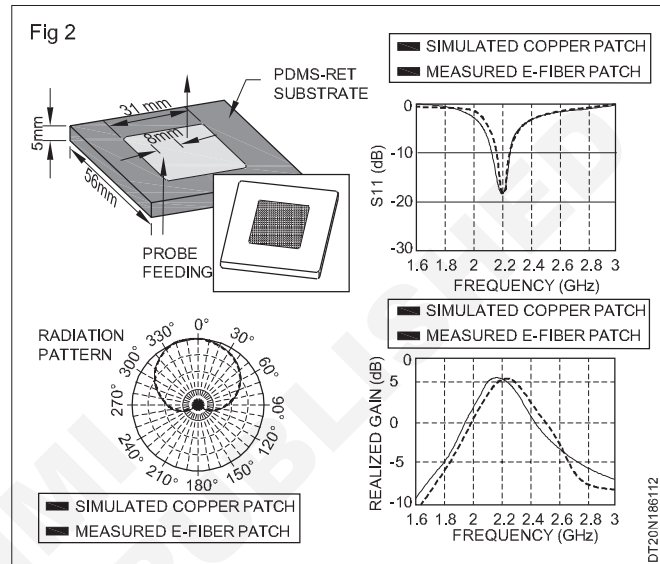

Patch antennas are widely used semi-directionals; a patch antenna can have a beamwidth of between 30 to 180 degrees and a typical gain of 9 dB.

**Yagi antenna**

antenna using in drone is directional antenna is the Yagi-Uda Array. A Yagi antenna uses several elements to form a directional array. Yagi antennas have beamwidths in the range of 30 to 80 degrees and can provide well in excess of 10 dBi passive gain.

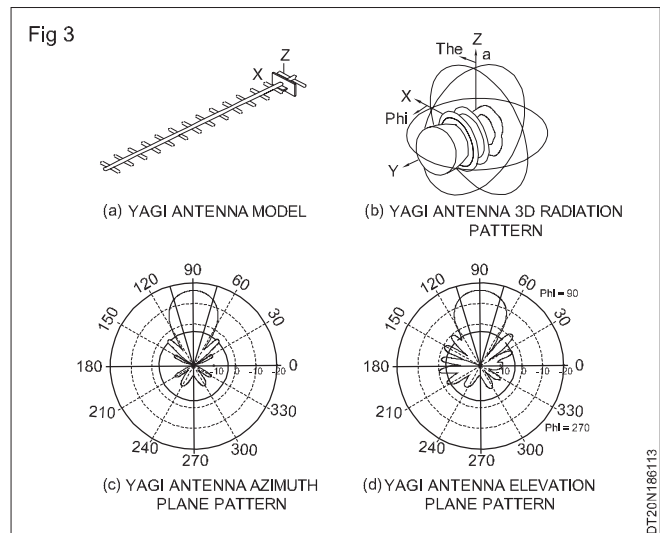

# Amplifier and different filters used in RF range.

**Objective:** At the end of this lesson you shall be able to

- state the amplifier
- state the meaning of frequency selective filters
- define an electronic filter
- state different types of filters
- define a low pass filter
- define cut-off frequency
- define a high pass filter.

## Fundamentals of MIC amplifier and different filter used in RF range

An amplifier is an electronic device that increases the voltage, current, or power of a signal. Amplifiers are used in wireless communications and broadcasting, and in audio equipment of all kinds. They can be categorized as either weak-signal amplifiers or power amplifiers.

### Filters

The term to filter, in general, means to selectively remove. For example, water filters are used to remove dust, dirt and disease causing germs from water. This means, the water filter selectively removes or blocks dust, dirt and disease causing germs but allows or passes purified water. In a similar way, in electronics, signals may consist of more than one frequency component. Then filters which selectively remove or allow a band of frequencies are used. Such filters are called Frequency selective filters. These filters are common in electronic circuits.

Frequency selective filters are electronic circuits comprising of electronic components such as resistors, capacitors, inductors, and sometimes active devices such as transistors, IC's etc., These circuits are designed to allow or to block (filter) a band of frequencies as shown in Fig 1. Filters may also be designed to allow or block a particular frequency component.

**In all the subsequent discussions, the term Filter refers to frequency selective filters only.**

Filters constructed using only passive components such as resistors, capacitors and/or inductors are called passive filters.

Filters constructed using active devices such as transistors or op-amps in addition to passive components are called active filters.

### Types of Filters

Referring to Fig 1, filters may be classified as,

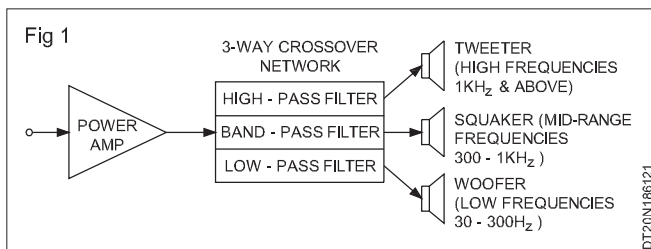

- Low pass filters - Passes or allow low frequencies (for example: 30 to 300 Hz)
- High pass filters - Passes or allows high frequencies (for example: 1 KHz and above)
- Band pass filters - Passes or allows a particular band of frequencies (for example: 300 Hz to 1 KHz)

### Low Pass Filter (LPF)

An ideal low pass filter is a circuit which passes all frequency signals from 0-Hz to a particular frequency called the cut-off frequency. This also means that, a low pass filter stops all signals having frequency beyond the cut off frequency as shown in Fig 2.

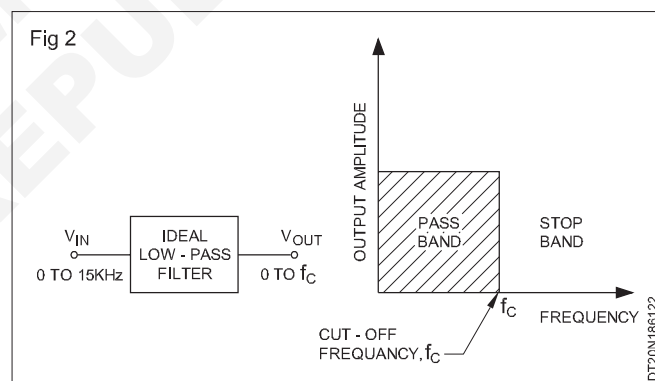

The frequency response of an ideal low pass filter as shown in Fig 2 will be constant in the pass band up to the cut off frequency  $f_c$ . Beyond  $f_c$ , called as the stop band the output of the filter is zero.

**However, in practice it is not possible to design a LPF having ideal characteristics as in Fig 2.**

A practical low pass filter can be defined as a circuit which allows all frequencies below a particular frequency called cut off frequency and attenuates heavily all frequencies above the cut off frequency as shown in Fig 3.

**Attenuation means reducing the amplitude/mag-nitude of the signal.**

Low pass filters can be constructed using,

- Resistors and capacitors - referred to as RC-filters
- Inductors and capacitors - referred to as LC-filters.

## Passive RC-low pass filter

A typical RC low pass filter and its frequency response is shown in Fig 4.

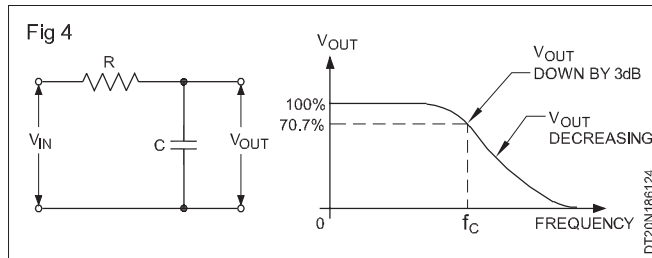
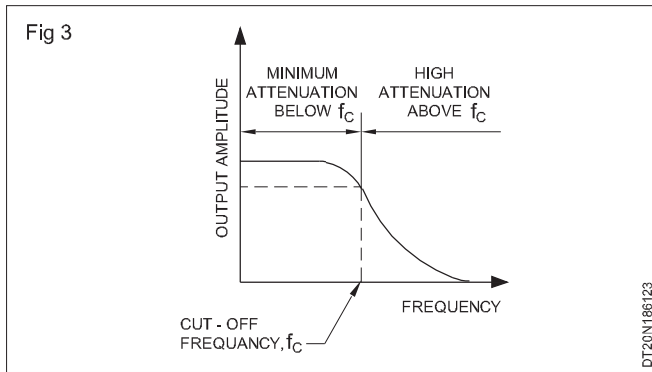

The output of the RC low pass filter is taken across capacitor C.

When input  $V_{in}$  is DC (0 Hz), capacitor C behaves practically as open circuit. At low frequencies, reactance of C ( $X_c = 1/2\pi fC$ ) is very high. Hence, at low frequencies capacitor behaves almost as open circuit. Therefore, at low frequencies output of filter is same as the input.

When input signal frequency increases, the capacitive reactance  $X_c$  decreases ( $X_c$  is inversely proportional to frequency).

Therefore, capacitor C gives a low resistance path for the high frequency signals to ground. Hence, as the input signal frequency increases the output of the filter decreases. This is shown in Fig 4. At a particular high frequency, capacitor C acts as a short circuit grounding all the input. When this happens,  $V_{out} = 0$  volt.

### Definition of cut-off frequency

The cut-off frequency,  $f_c$  is defined as the frequency at which the power output of the filter is one half of the input power. In terms of voltage, at cut-off frequency  $f_c$ , the output amplitude will be 70.7% of the input amplitude as shown in Fig 4.

Cut off frequency  $f_c$  of a RC low pass filter can be calculated using the formula,

$$f_c =$$

where, R = Resistance in ohms

C = Capacitance in farad

$f_c$  = Cut off frequency in Hz.

**A low pass filter constructed using one resistor and one capacitor as shown in Fig 4 is known as a single stage LPF. This is also called a single pole LPF. Since the output of a LPF lags from input, LPFs are also referred to as Lag networks.**

## Measurement of gain in DECIBEL (dB)

Gain of a LPF is given by,

$$\text{Gain in dB} = 20 \log V_{out} / V_{in}$$

At cut-off frequency, since the output voltage will be 70.7% of the input ,

$$\text{Gain of a LPF at cut-off frequency } f_c = 20 \log (0.707)$$

$$= -3\text{dB}$$

Hence, in a LPF,  $f_c$  is also called the 3dB frequency of the filter.

## ROLL-OFF

The rate at which the output level of LPF decreases depends on the number of stages in the LPF as shown in Fig 5.

The rate of decrease in output level, or rate of increase in attenuation after the cut off frequency  $f_c$  is called roll-off. Roll-off of a filter is expressed in decibels-per-decade (dB/decade) or decibels-per-octave (dB/octave).

The higher the number of stages in a LPF, the higher will be the roll-off rate and better will be the performance of the LPF as shown in Fig 5.

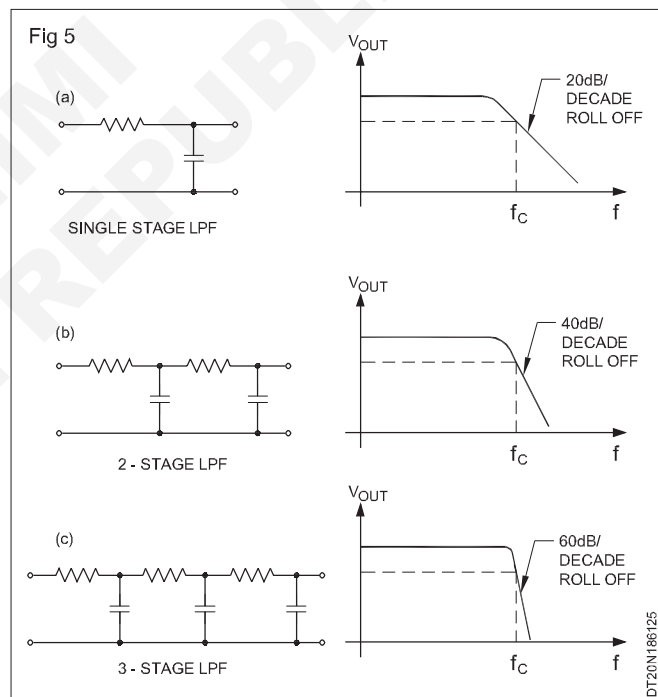

The disadvantage of cascading more number of filter stages is, the attenuation to the input signal in the pass-band increases as more number of resistors come in series between the input and output.

In general, a n-pole (n-stage) LPF will have  $20 \times n$  dB/decade roll off.

## Passive LC Low Pass Filter

Low pass filter can be constructed using an inductor (L) and a capacitor (C). A typical L-C low pass filter designed for  $f_c = 1$  KHz is shown in Fig 6.

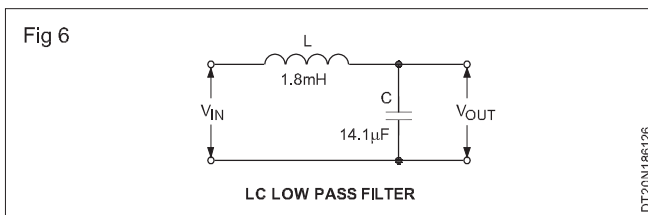

The frequency response of LC low pass filter and RC low pass filter will have the same shape. The cut-off frequency in LC low pass filter is given by,

where,  $L$  = inductance value in henry

$C$  = capacitance value in farad.

In audio frequency circuits, LC low pass filters are not preferred as the physical size of the inductor will be large. However, in radio frequency applications (r.f), LC filters are popular as the inductor size will be small at such high frequencies.

### Applications of Low Pass Filter

Low pass filters are used in wide variety of applications. A few such applications are;

- 1 In DC power supplies as ripple filter to block AC ripples from reaching the output.
- 2 In tone control circuit of amplifiers, tape recorder amplifiers etc., to separate low frequencies (Bass signals).
- 3 In cross over networks (shown in Fig 1) in speaker boxes.

### High Pass Filters (HPF)

A High pass filter is a circuit that only allows signals above a particular frequency called cut-off frequency to pass through it. An ideal HPF blocks signals whose frequency is below the cut off frequency  $f_c$  as shown in Fig 7a. The frequency response of a practical HPF is shown in Fig 7b.

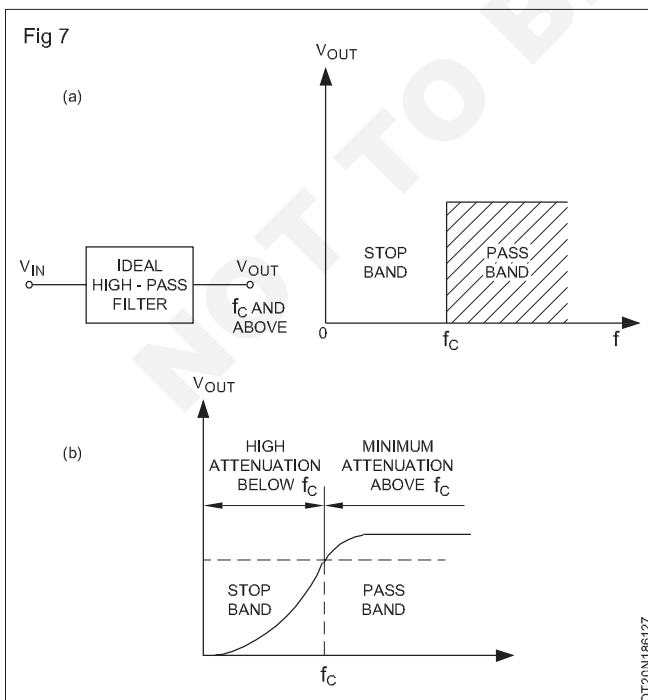

### Applications of High Pass Filters

High pass filters are used in wide variety of applications. A few such applications are;

- in tape recorders and amplifier tone control network
- in loud speaker cross over network
- in scratch filters
- in communication transmitters and receivers.

### Band Pass Filters (BPF)

A band pass filter is a circuit that allows all the signals whose frequency is between two frequency limits called lower cut off frequency ( $f_L$ ) and upper cut off frequency ( $f_U$ ). Band pass filter heavily attenuates signals whose frequency is less than the lower cut off frequency or more than the upper cut off frequency as shown in Fig 8.

### Applications of Band Pass Filters

Band pass filters are used in wide variety of applications. A few such applications are;

- in cross over network
- as voice filters in amplifiers
- in graphic equalizer networks
- in communication transmitters and receivers.

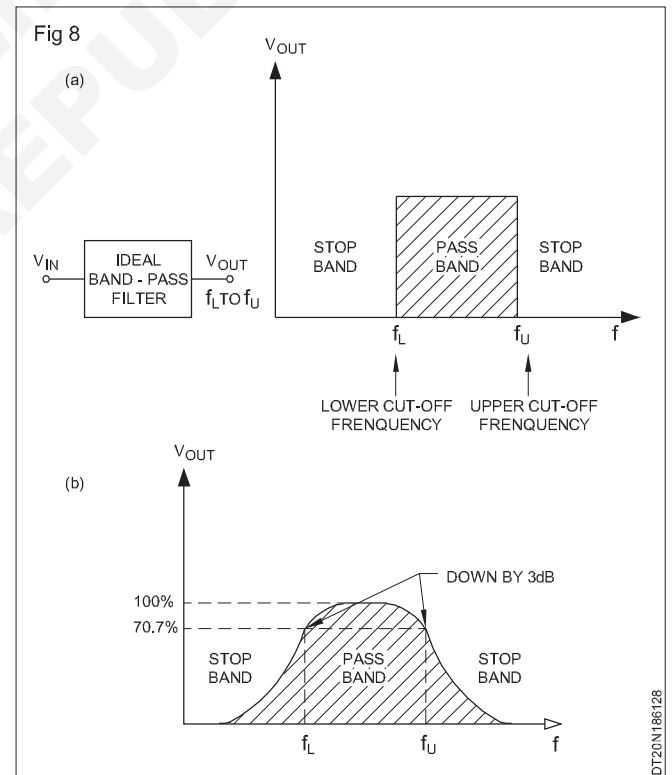



# Understand of RC transmitter and receiver. About GPS and its usage

**Objective:** At the end of this lesson you shall be able to

- state the RC transmitter receiver
- explore the GPS and its characteristics
- state the GPS navigation
- explore the usage of GPS signal.

Radio frequency (RF) is a measurement representing the oscillation rate of electromagnetic radiation spectrum, or electromagnetic radio waves, from frequencies ranging from 300 gigahertz (GHz) to as low as 9 kilohertz (kHz).

With the use of antennas and transmitters, an RF field can be used for various types of wireless broadcasting and communications.

## Radio Frequency Spectrum Ranges

Designation	Abbreviation	Frequencies	Wavelengths
Very low Frequency	VLF	3kHz-30kHz	100Km - 10Km
Low Frequency	LF	30kHz - 300kHz	10Km - 1 Km
Medium frequency	MF	300kHz - 3 MHz	1Km - 100m
High Frequency	HF	3MHz - 30MHz	100m - 10m
Very high Frequency	VHF	30Mhz - 300GHz	10m - 1m
Ultra high Frequency	UHF	300MHz - 3GHz	1m - 100mm
Super high frequency	SHF	3GHz - 30GHz	100mm - 10mm
Extremely high frequency	EHF	30GHz - 300GHz	10mm - 1mm

The components required to make rf transmitter and receiver circuit are –

433mhz rf transmitter and receiver circuit module.

- 1 Encoder IC ( HT12E )
- 2 Decoder IC ( HT12D )
- 3 18 pin IC base x 2
- 4 Momentary push button x 4
- 5 LED's x 5
- 6 Resistors – 1 MΩ, 33 KΩ, 470 Ω
- 7 IC 7805 x 2
- 8 9V battery x 2

9 Battery connector x 2

10 Bread board

11 Vero board

12 Wires



Table 1

PIN Name	Pin Description
VCC	Used to power the RF receiver module.
GND	Ground pin of the module. Connect it with the controllers and encoder/decoders GND pin.
DATA	This is the data pin of the transmitter. It takes the data from the microcontroller or encoder and broadcast it via the antenna.
ANT	The antenna pin is not necessary to use but it is recommended. The module can only operate max 3 meters without an antenna but its range can be extendable up to 100 meters by using a small hookup wire as an Antenna.

Table 2

PIN Name	Pin Description
VCC	Used to power up the RF receiver module. Unlike the transmitter, the supply voltage of the receiver is 5v.
GND	Ground pin of the module. Connect it with the controllers and encoder/decoders GND pin.
DATA	These pins output the digital data received. The two center pins are internally connected, so we can use either one of them for data output.
ANT	The antenna pin is not necessary to use but is recommended. The module can only operate up to 3 meters without an antenna but its range can be extended up to 100 meters by using a small hookup wire as an Antenna

### 433MHz RF Transmitter Module Features:

- The Transmitter offers only one-way communication through 433.92MHz frequency at 1Kb data rate
- It operates at a range of 3-12V which is also the power operating volts of most of the microcontrollers and boards.
- The module uses the ASK (Amplitude Shift Key) modulation method to transmits the data.
- It is one of the very low-cost power effective modules for both commercial, hobbyist, and developers.
- 433MHz Transmitter is one of the cheapest RF transmitters and it has a lot of applications and can be used interface with almost every microcontroller.

### 433MHz RF Receiver Module Features:

- The RF receiver delivers the output to the data pin in an encoded form.
- The operational voltage range of the module is 5V maximum.
- The frequency of the receiver can be changed using a node present on it.
- It is one of the popular and cheapest receivers and has low power consumption.
- 433MHz RF receiver module uses the ASK signal as an input.

### Specifications of 433MHz RF Transmitter Module:

- Max range with the antenna in normal Conditions: 100 Meters
- RX Receiver Frequency: 433 MHz
- RX Typical Sensitivity: 105 Dbm
- RX Supply Current: 3.5 mA
- RX IF Frequency: 1MHz
- RX Operating Voltage: 5V
- TX Frequency Range: 433.92 MHz
- TX Supply Voltage: 3V ~ 6V
- TX Output Power: 4 ~ 12 Dbm

### Specifications of 433MHz RF Receiver Module:

- Max range with the antenna in normal Conditions: 100 Meters
- RX Receiver Frequency: 433 MHz
- RX Typical Sensitivity: 105 Dbm
- RX Supply Current: 3.5 mA
- RX IF Frequency: 1MHz
- RX Operating Voltage: 5V
- Get connection checked by the instructor
- Working of 433 MHz RF transmitter and receiver Module

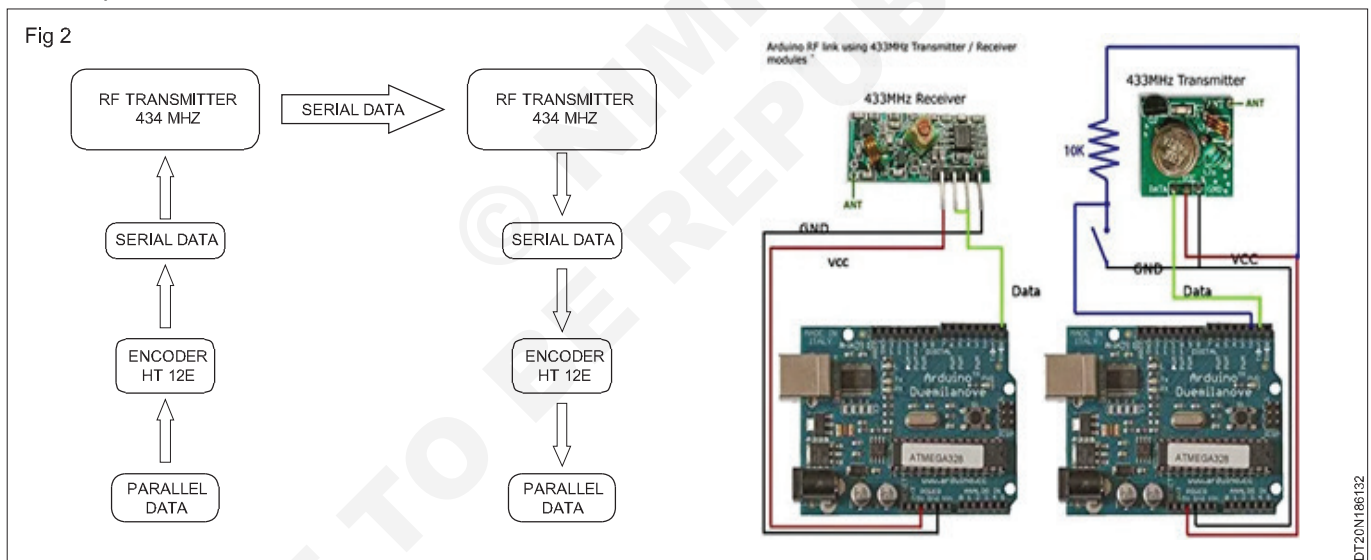

### Fundamentals of GPS

GPS module helps the drone to navigate longer distances & records the complete info of particular locations on land. GPS navigations track the distance of flight areas. GPS helps the drone to return back home safely. Modern drones have a GPS module if they lose connection with the controller. It helps the drone to make it safe. GPS module is responsible for drone latitudinal, longitudinal & elevation provision points.

**Note: GPS increase the stability of drone, GPS able to hold the position in air without facing drift balance.**

The Global Positioning System (GPS) is a worldwide radionavigation system formed from a constellation of 24 satellites and their ground stations. GPS uses these "man-made stars" as reference points to calculate positions

accurate to a matter of meters. In fact, with advanced forms of GPS measurements can be taken to better than a centimeter. In a sense it's like giving every square meter on the planet a unique address. GPS receivers have been miniaturized to just a few integrated circuits and so are becoming very economical. These days GPS is finding its way into cars, boats, planes, construction equipment, movie making gear, farm machinery, even laptop computers. Soon GPS will become almost as basic as the telephone.

### How GPS Work

The GPS receiver gets a signal from each GPS satellite. The satellites transmit the exact time the signals are sent. By subtracting the time the signal was transmitted from the time it was received, the GPS can tell how far it is from each satellite. The GPS receiver also knows

the exact position in the sky of the satellites, at the moment they sent their signals. So given the travel time of the GPS signals from three satellites and their exact position in the sky, the GPS receiver can determine the position in three dimensions – east, north and altitude. To calculate the time the GPS signals took to arrive, the GPS receiver needs to know the time very accurately. The GPS satellites have atomic clocks that keep very precise time, but it's not feasible to equip a GPS receiver with an atomic clock. However, if the GPS receiver uses the signal from a fourth satellite it can solve an equation that lets it determine the exact time, without needing an atomic clock.

If the GPS receiver is only able to get signals from 3 satellites, it can still get the position, but it will be less accurate. The GPS receiver needs 4 satellites to work out the position in 3-dimensions. If only 3 satellites are available, the GPS receiver can get an approximate position by making the assumption that are at mean sea level. A modern GPS receiver will typically track all of the available satellites simultaneously, but only a selection of them will be used to calculate the position. To determine the location of the GPS satellites two types of data are required by the GPS receiver: the almanac and the ephemeris. This data is continuously transmitted by the GPS satellites and the GPS receiver collects and stores this data.

### How to use GPS module for Base Station

#### Applications

The following things are required to use GPS for base station applications:

#### External Antenna

This antenna is mounted outside BTS box on the tower facing sky. This antenna is mounted on the BTS chassis using screws.

#### GPS module

Antenna is connected to the GPS module using RF cable. This GPS module is mounted inside BTS box.

#### Processor

BTS's processing unit i.e. FPGA, CPLD or other base band processor connected to the GPS module using UART (or SPI, I2C etc) interface. This processor send command to GPS module and receives desired response from it.

#### Latitude, Longitude and Altitude.

to determine the 3 – Dimensional position of the GPS Receiver i.e. its Latitude, Longitude and Altitude. We will see a step – by – step procedure to determine the 3 Dimensional location of the GPS Receiver.

#### Position of the Receiver in 3D Space

Let us assume that the locations of the satellites with respect to the GPS Receiver are already known. If Satellite 1 is at a distance of  $D_1$  from the Receiver, then it is clear that the position of the receiver can be anywhere of the surface of the sphere that is formed with satellite 1 as center and  $D_1$  as its radius.

If the distance of a second satellite (Satellite 2) from the receiver is  $D_2$ , then the position of the receiver can be limited to the circle formed by the intersection of two spheres with radii  $D_1$  and  $D_2$  with Satellites.

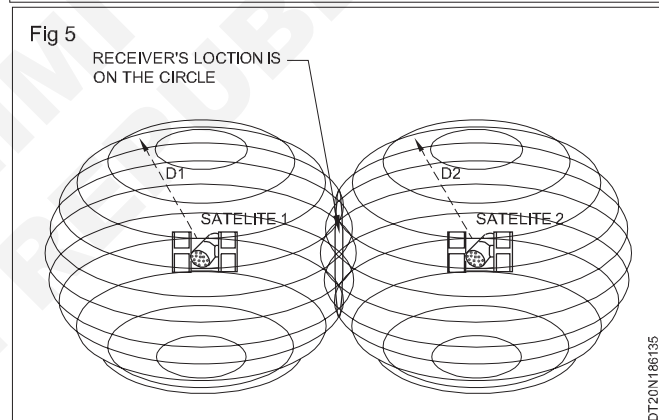
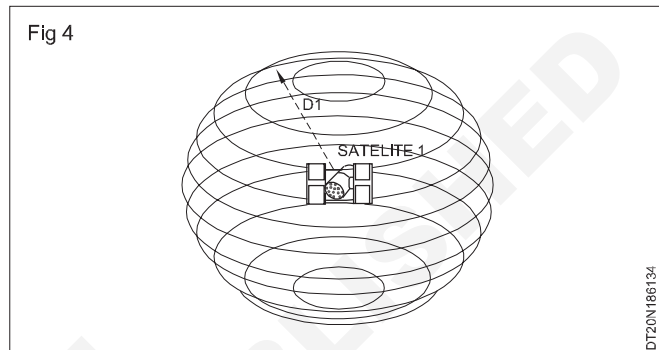
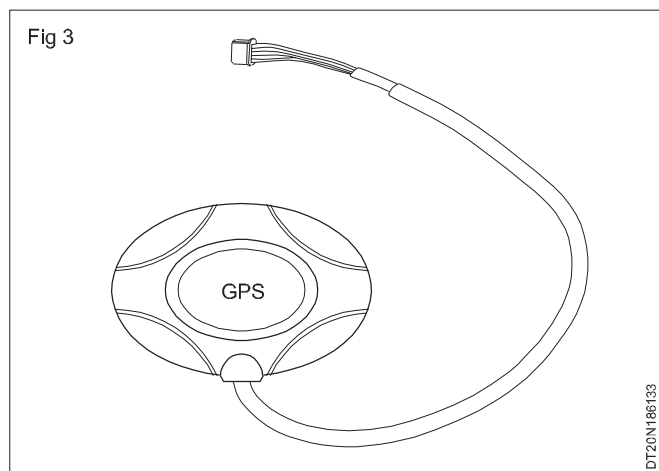

1 and 2 at the centres respectively. From this image, the position of the GPS Receiver can be narrowed down to a point on the circle of intersection. If we add a third satellite (Satellite 3) with a distance  $D_3$  from the GPS Receiver to the existing two satellites, then the location of the receiver is confined to the intersection of the three spheres i.e. either of the two points.

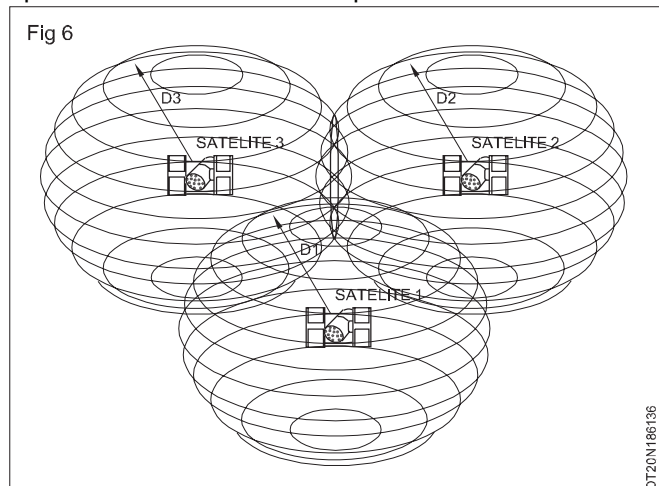

**Illustrate flight controller board and Electronic Speed Controller**

**Objectives:** At the end of this lesson you shall be able to

- define the Flight controller board
- explore FCB connection
- define the ESC
- explore the ESC connection
- state the FCB commands and configuration.

**Introduction to Flight controller boards**

The flight controller is used to direct the way for hovering. It looks like a small electronic circuit board. Mostly the FCB should have multiple features for flight control.

The command of the pilot is multiple features for flight controlling installed in FC. it directs the motors accordingly. "FC is the brain of drone". This will perform with the commands instructed by a pilot through interpreting signals from the receivers. FC monitors the battery, manage motor speeds & ESC switching commands are regulated by it.

Sensors are also employed in most flight controllers for calculations. When the drone moves high range altitudes, the gyroscope automatically provides orient instructions for better hovering. GPS mainly helps to take auto-pilot moves.

**Flight controller boards connectivity with different peripherals**

**Introduction Electronic Speed Controller**

The electronic speed controller (controlling electronic device) is used to maintain the speed control of the electric motor & it executes the dynamic break based on RC models; they are powered electrically. In the case of brushless motors, they produced a low voltage source of 3-phase electric power energy to run the motor. ESC is a separate control unit for the throttle receives channel. Most RC produces connect the electronic gadgets in entry-level vehicles.

It controls the flight direction & speed of drone. "Every minute components pays the value of whole structure". The electronic speed controller of commercial drone converts the DC battery power to AC power, the AC power run BLDC motors for continuous rotation of propeller to up lift.

**Electronic Speed Controller connection with motor**

**ESC configurations using FCB to control speed and direction of motor**

**Calibration ESCs**

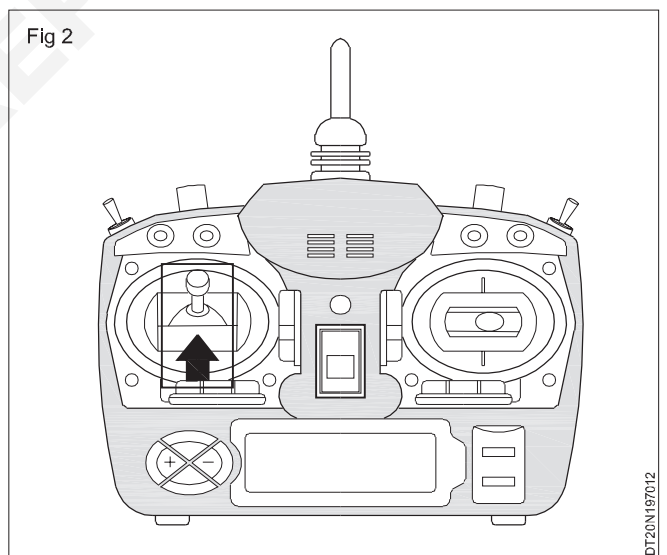
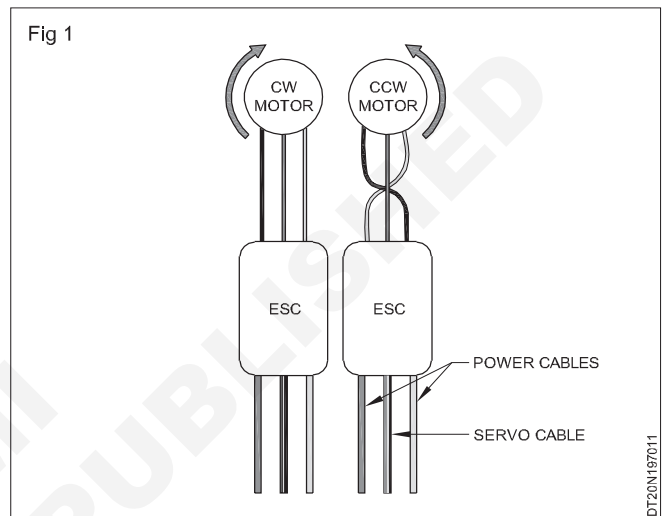

- 1 Firstly, connect one ESC three-wire cables into the throttle channel (mostly channel 3) of the RC receiver.
- 2 second trainee turns "ON" the transmitter and set throttle stick to maximum position (at 100%).

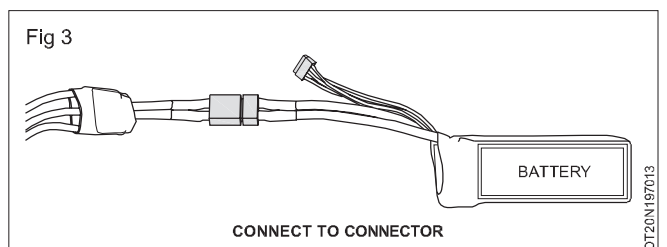



- 3 Third trainee, power to drone by connect the LiPo battery.
- 4 Listen a musical tone than one or two beeps.

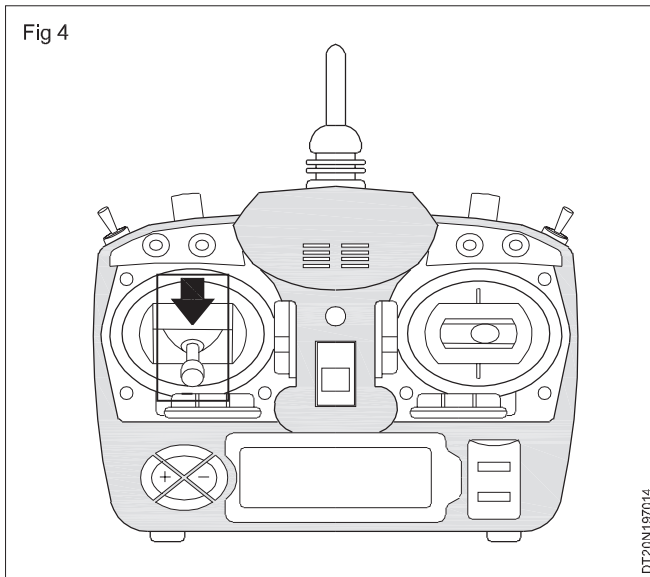

- 5 After the two beeps, pull the transmitter's throttle stick down to its minimum position (at 0%).
- 6 Then a number of beeps and finally, a single long beep indicating the end points have been set and the ESC is calibrated.

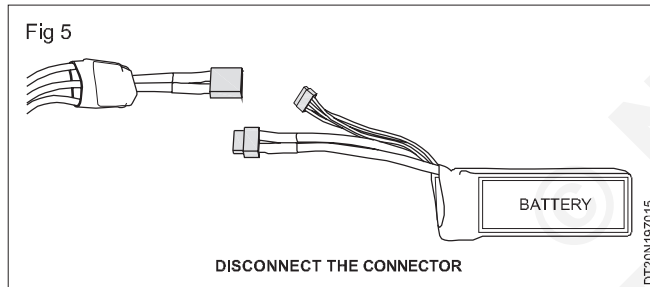

- 7 Disconnect battery.
- 8 Repeat these steps for all other ESCs.
- 9 After calibration, recheck those motors should work in coordination with throttle stick i.e., as soon as the throttle stick is moved from its minimum position, motor should start rotating.
- 10 Make sure that all ESC's are calibrated and are working properly.

- 11 Get it checked by your instructor by Arm your Drone then, put throttle (10%) and check whether all motors are rotating at the same speed and start at the same time.
- 12 Disarm your drone.
- 13 If the motors do not all start at the same time and rotate at the same speed, the ESCs are still not properly calibrated so, repeat above step again.

### Motor Orientation Checking

Step 1: Switch on the remote and give power supply to drone

Step 2: Remove the Motor 1 pin of the controller and connect it to the channel 3 of the Receiver

Step 3: connect the Motor 1 wires to the ESC cables and give the power supply if the motor was rotating in counter clock wise direction then it will be in correct direction.no need to change the any wires go for the another motor repeat the same process

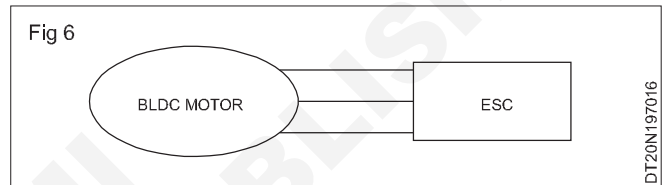

Step 4: if the motor 1 was rotating in the counter clockwise direction then change the any two cable connections of the motor 1 and Esc then give the power supply and check the motor rotation

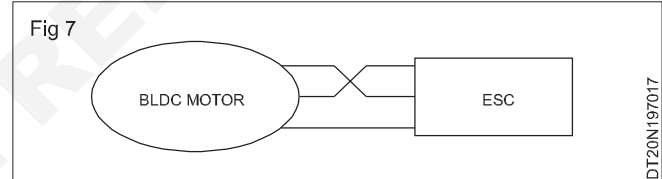

Step 5: Repeat the same process for all the remaining motors

Fig 8

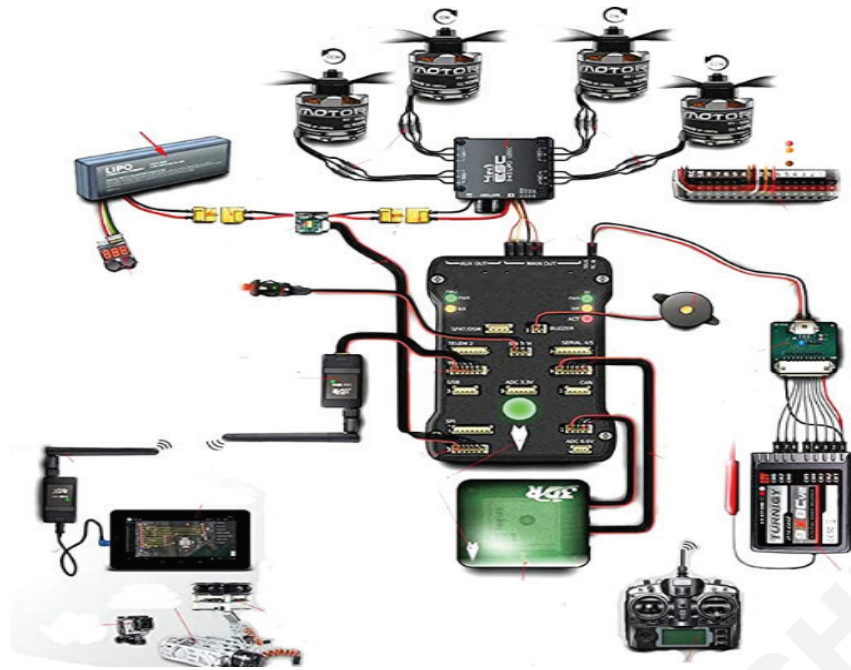

Introduction to flight control box and various commands used in it.

Fig 9

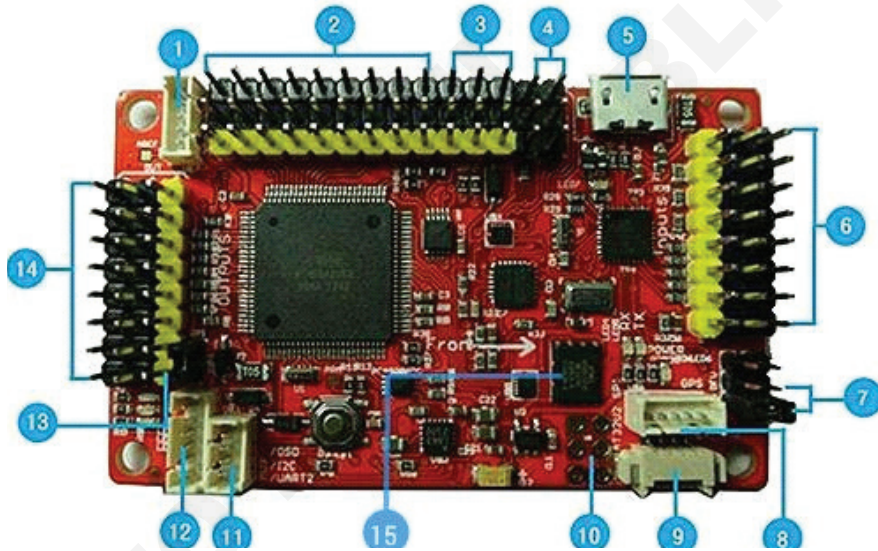

- 1 Data Transmission port
- 2 Analog Sensor port
- 3 Autostability Gimbal Output
- 4 Almega 2560 SPI Online programming port (Useful for Optical Flow Sensor)
- 5 USB port
- 6 Remote Control Input
- 7 Function Selection Jumper
- 8 GPS port
- 9 12c External Compass port
- 10 Almega 32U2 SPI Online programming port
- 11 Multifunction Configurable Mux port (OSD is the Defaulted Output)
- 12 Power port
- 13 ESC Power Supply Selection Jumper
- 14 ESC Output port

15 Dataflash

**Configuration techniques for FCB with various motors, GPS etc.**

Fig 10

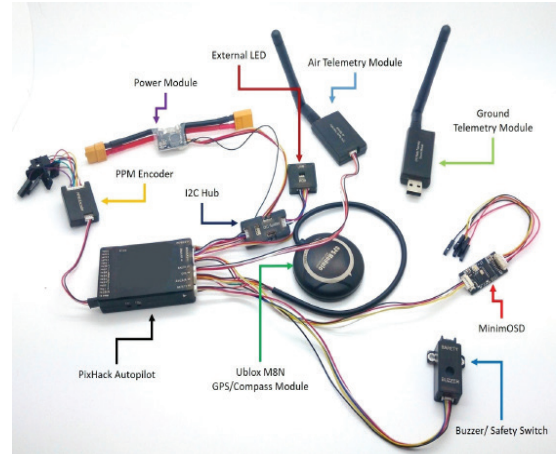



## Make the FCB connection as shown in the Fig 10

### Understand GPS

- 1 The Global Positioning System (GPS) is a satellite constellation that provides extremely precise positioning, navigation, and timing (PNT) measurements throughout the world. Precision agriculture, driverless vehicles, maritime or aerial surveying, and defense applications have all benefited from GPS, which was one of the first satellite positioning systems.
- 2 The Global Positioning System, or GPS, is a satellite navigation system that offers location, velocity, and time synchronization. GPS may be found almost anywhere. GPS systems can be found in your automobile, smartphone, and watch.

### Interface GPS with FCB

- 1 Set the configurations of the FCB which include Oscillator configuration.
- 2 Set the Desired port for LCD including TRIS register.
- 3 Connect the GPS module to the FCB using USART.
- 4 Initialize the system USART in continuous receive mode, with 9600 baud rate and LCD with 4bit mode.
- 5 Take two-character arrays depending on the Length of Latitude and Longitude.
- 6 Receive one character bit at a time and check whether it is started from \$ or not.
- 7 If \$ Receive then it is a string, we need to check GPGGA, these 5 letters and the comma.
- 8 If it is GPGGA, then we will skip the time, and look for the Latitude and Longitude, we will store the Latitude and Longitude in two-character array until N (North) and E (East) not received.
- 9 We will print the array in LCD.
- 10 Clear the array.

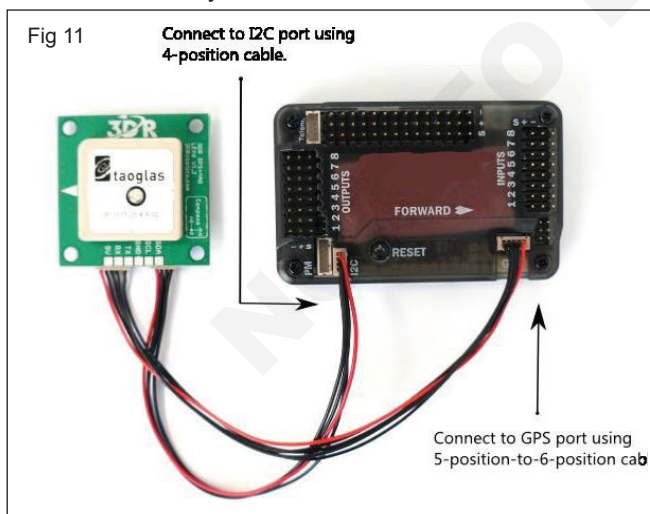

## Configuration techniques for FCB with motors

- Turn transmitter on and ensure the flight mode switch is set to Stabilize and Make sure there are no propellers attach on drone
- Connect battery.
- Arm drone giving armed command
- When you can Arm successfully, apply a 10% of throttle, and observe and note spin direction of each motor.
- Reverse if any motor spinning in the wrong direction.
- Motor Direction is reversed simply by interchanging two of the three ESC to motor power leads.

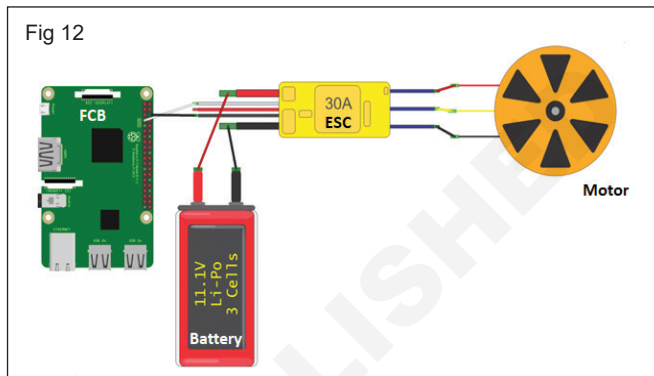

## Configure, test and record FCB with battery to monitor battery level

- Long press the Set key, power supply to the product, enter the setup interface
- Press the Set key to select the battery specification (Lead-acid battery(P), Lithium battery (L), Fe battery(F))
- Short press the Function key to select the number of battery strings (increasing for the set button, decreasing for function button)
- Long press the Function key to set s mode



## Various applications of drones in different field.

**Objectives :** At the end of this lesson you shall be able to

- state the different type of drone
- understand the drone application
- state the remote sension and mapping
- state the use of OpenCV
- express the gimbal stabilization.

### Fundamental applications of various types of drones

**1 Military drones:** Military drones are used over a decade of time. UAV used for surveillance, monitoring, commanding target on enemies. However, for this technology Armed forces showing much more interest and they are investing develop the UA. This is building a greater opportunity for drone manufacturing.

**2 Agriculture:** Agriculture is an endless process which is made by farmers. The cost expenses for raising up a crop is expendable. This issue will be a burden to spend more money to Agri-Field. To avoid such difficulties, drone providing so many solutions. We all risen-up by learning that (honey-bees) are used for pollinating flower drones also been used to pollinate it will be proved one day, it can compensate the bee declining population. The productivity of field increases. The pest spraying be done with a drone. Drone access the data & provide the information of the field. UAV's have thermal- imaging cameras to detect the diseased parts of the plant for Ex: - raptor maps and Agriculture analytics start up using drone to a better forecast of field. They assisting farmers for potential harvest. Airborne seed dispersal is also possible by drone. Abundant robotics also evolving a solution for autonomously picking.

Fig 1



**Figure Drone use for sparing pesticides over crops**

Agriculture Drone useful:

- 1 Soil Analysis:
- 2 Spraying and sowing:
- 3 Plant Count:

4 Health Analysis (Fruits, leaves and flowers)

5 Data – Analyzation

6 High- efficient work

7 Eco- friendly

8 Irrigation

9 3-D mapping (Land Surveying)

**3 Mining:** Drones are used to capture the volumetric data on stockpiles with unique cameras & able to survey Mining operations from the air, which reduces the surveyors on the ground. Mining also being held by autonomous UGV's.

On site drone solution for mining companies to operate work like surveying, security enhancing, measuring materials. The drones are totally autonomous, which can store the data on cloud platform services.

**4 Mapping:** So many lands are unavailable to mankind. To take 3D – Mapping. Images, which is easier to find the lands & makes them usable. This can be an organization to make every one available. Finding the location made easier by drone.

**5 Drone Racing & Gaming Sports:** Like video gaming, drone gaming be a trend of today. Aerial racing fills us with happiness because no incidents happened in oriented space. Being a hobby to everyone. It creates recreational thoughts in young minds. This aerial flight exercise creates un-condition practices to all. Precautions are mandatory who are participating in drone racing.

**6 Security:** Security is most important high alert systems enabling for comprehensive surveillances in industries & residential properties. Even through security is maintain but suspicious activities held at some place. Drone deploys with live streaming then immediately alarm triggered, make the security teams alert and footages can be captured.

**7 Solar Inspection:** Now a day's solar project has been developed in many places, it requires solar inspections. To avoid manual work, presently drones are taken part for doing solar inspection and it sends data to Maintenance Department for analyse.

**8 Surveillance & Aerial Monitoring:** Drone are used as spy with all certifications. We can avoid risk, issues & security some problems surveillances done by drone are given below.

- 1 Security
- 2 Traffic monitoring
- 3 Board Security

**Implementation and handling of HD and thermal image camera for remote sensing and mapping**

Remote sensing is the process of detecting and monitoring

the physical characteristics of an area by measuring its reflected and emitted radiation at a distance.

- 1 Cameras on drone take images of large areas on the surface
- 2 Cameras on drone can be used to make images of temperature changes on the ground.

Remote sensing Process (Fig 2)

Thermal image camera for remote sensing (Fig 3)

Fig 2

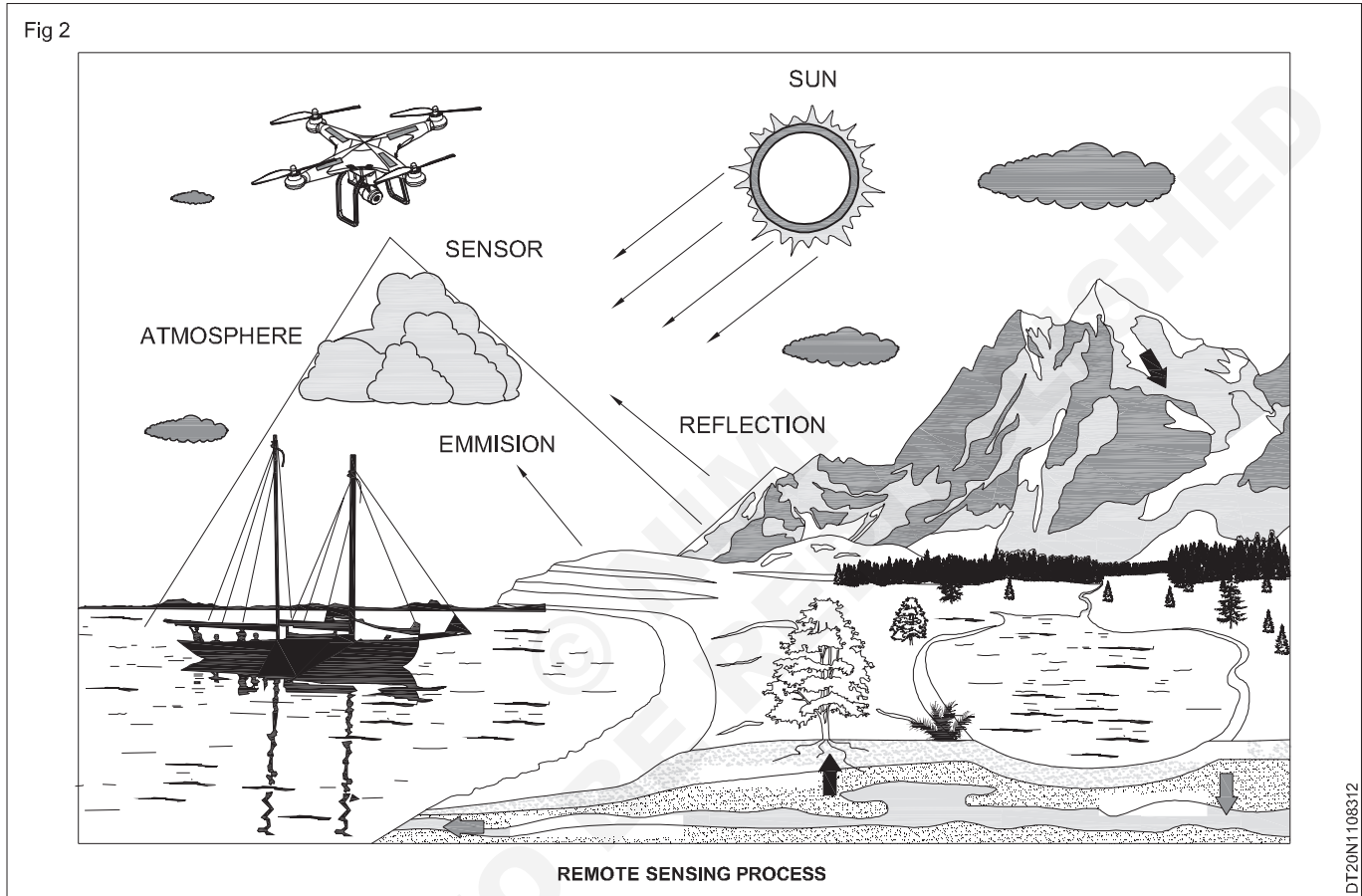
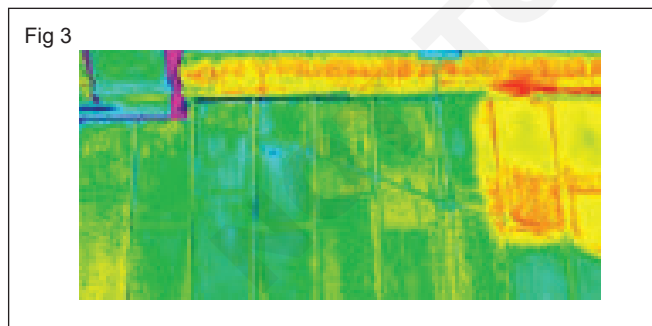

Fig 3



**3D Mapping**

Photogrammetry and orthomosaics for creating 3D maps. Orthomosaic is a combination of processes. Orthorectification or creating an orthophoto means adjusting the image for terrain relief, lens distortion and camera tilt so that it can be used for actual measurements. Mosaic combines multiple images into one.

The resulting maps are now highly accurate and can be used for various industrial applications such as civil engineering, surveying, urban planning and land management.

**3D Modeling**

Convert mapping into 3D modeling.

3D modeling can be used for commercial purposes like real estate; or, like the image at the top of the page, to create more informative maps. A more oblique shots, providing images of the facades. With those, modeling software can create realistic 3D models. (Fig 4)

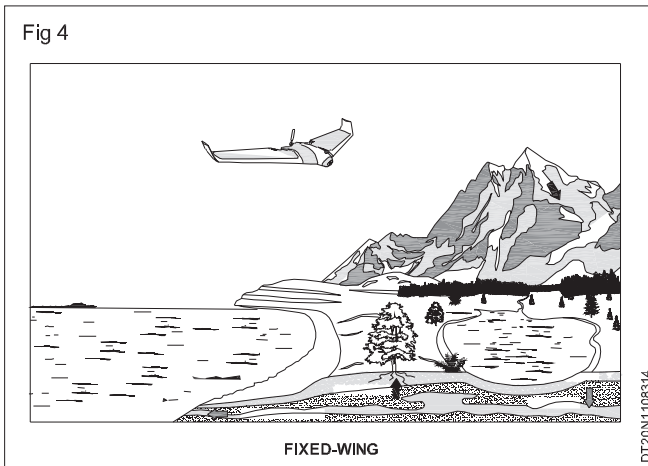

Introduction to photogrammetry. Image recognition with OpenCV using the drone camera. Fundamental techniques for stabilizing Gimbal.

### Introduction to photogrammetry

During a UAV flight, several images need to be taken at regular intervals to ensure that images overlap. This is critical so that measurements between objects present in the images can be made. Broadly, this process is known as photogrammetry. For imagery to be used for data analysis and mapmaking, relevant metadata is required for imagery stitching. These metadata are inserted automatically by a microcomputer onboard a UAV.

**Image recognition with OpenCV using the drone camera.**

### Steps Required to Create an Object Detection Cascade File (Fig 5)

- 1 Install OpenCV

- 2 Create a directory that will house your project and its images
- 3 Acquire or develop positive images
- 4 Create an annotation file with the paths to your objects in the positive images
- 5 Create a .vec file that contains images of your objects in binary format using the annotation file above
- 6 Develop and acquire negative images that do not contain the object you wish to detect
- 7 Train the cascade
- 8 Test your cascade.xml file

Fig 5



### Fundamental techniques for stabilizing Gimbal (Fig 6)

Gimbal stabilizes the tilt, pan, and roll of a camera move side to side, up and down, back and forth, the gimbal stabilizes the video it shaky. Tilting is moving up and down.

Fig 6

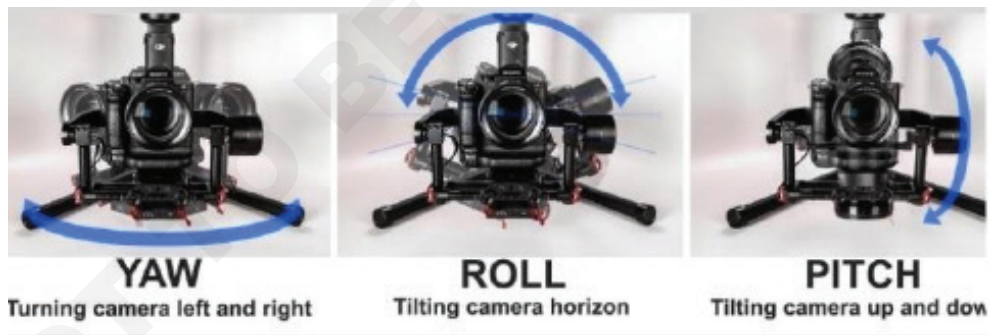



**Understand software, its debugging and python programming**

---

**Objectives:** At the end of this lesson you shall be able to

- define the software debug
  - state the coding error
  - illustrate the python and Arduino
  - explain firmware and hardware integration
  - explain the cause of coding error
  - define ground base station
  - explain about the preventive measurement.
- 

**Introduction to software debug tool use to identify coding errors at different stages of development.**

Software debugger tool is the development process to identifying coding errors at various stages of the operating system.

**List of the best tools to debug Python applications**

- 1 PyCharm
- 2 PDB
- 3 Pyringe
- 4 Pyshield
- 5 Python Tools for Visual Studio
- 6 PyScripter
- 7 PyDev
- 8 Vprof
- 9 PySnooper

**Debugging tools and analysed options based on the following criteria:**

- An integrated development environment guide fault-free coding
- A code displays that colour codes keywords
- Code element completion or a keyword selection list
- A scanner to verify existing code and spot syntax errors or security weaknesses
- Code library management with version control
- A free trial for a risk-free assessment opportunity

Less price for analyzer

**Debugging strategies include the following**

- Static analysis
- Print debugging
- Remote debugging
- Post-mortem debugging

**Introduction to various drone operation using Python and Arduino and setup development environment.****Python Drone Programming**

Drone coding with python using dronekit.

**ArduPilot SITL**

SITL stands for 'Software-In-The-Loop'.

- The same source code can compile for a real autopilot board
- test the real firmware right from computer
- It is also possible to test high level dronekit python scripts against the simulated ardupilot before trying the code out in the field.
- ArduPilot SITL simulator like Gazebo.

**Download the ArduPilot Source Code**

- git clone <https://github.com/ardupilot/ardupilot>
- cd ardupilot
- git submodule update – init – recursive
- cd ArduCopter
- ../Tools/autotest/sim\_vehicle.py – console – map

Download Dronekit Python

pip install dronekit==2.9.2

Dronekit Python Script for Arm and Takeoff

```
from dronekit import connect, VehicleMode, LocationGlobalRelative, APIException
```

```
import time
```

```
import socket
```

```
import exceptions
```

```
import math
```



#####FUNCTIONS#####

### ##Function to arm the drone props and takeoff at targetHeight (m)

```
def takeoff_and_arm(targetHeight):
    while vehicle.is_armable!=True:
        print("Drone is Arming.")
        time.sleep(1)
    print("Drone Armed")
    vehicle.mode = VehicleMode("GUIDED")
    while vehicle.mode!='GUIDED':
        print("Drone switch to Guided Mode")
        time.sleep(1)
    print("GUIDED MODE. is ON!!")
    vehicle.armed = True
    while vehicle.armed==False:
        print("Drone is Arming.")
        time.sleep(1)
    print("props are spinning!!")
    vehicle.simple_takeoff(targetHeight)
    while True:
        print("Current Altitude: %d"%vehicle.location.global_relative_frame.alt)
        if vehicle.location.global_relative_frame.alt>=.95*targetHeight:
            break
        time.sleep(1)
    print("Target height reached!!")
return None
```

#####MAIN EXECUTABLE#####

### ####sim\_vehicle.py opens up port on localhost:14550

```
vehicle = connect('127.0.0.1:14550',wait_ready=True)
```

### ####Arm the drone and takeoff into the air at 10 meters

```
arm_and_takeoff(10)
print("Vehicle reached target height")
```

### ####Once drone reaches target altitude, change mode to LAND

```
vehicle.mode=VehicleMode('LAND')
while vehicle.mode!='LAND':
    print("Drone switch to LAND mode")
    time.sleep(1)
```

```
print("Drone LAND mode is ON.Touch ground quickly")
```

### Arduino and setup development environment

Download the Arduino Software (IDE)

Go to latest version of the download page.

Select the Installer (.exe) and the Zip packages.

installs directly to use the Arduino Software (IDE), including the drivers.

After download finishes, proceed with the installation and please allow the driver installation process when get a warning from the operating system.

Choose the components to install. (Fig 1)

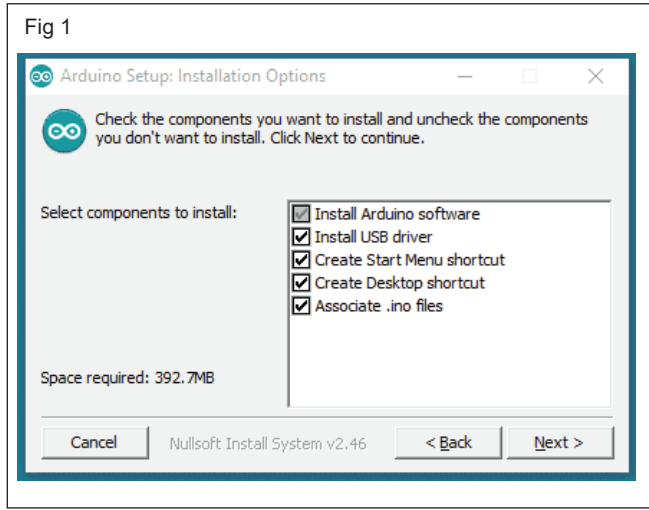

Choose the installation directory. (Fig 2)

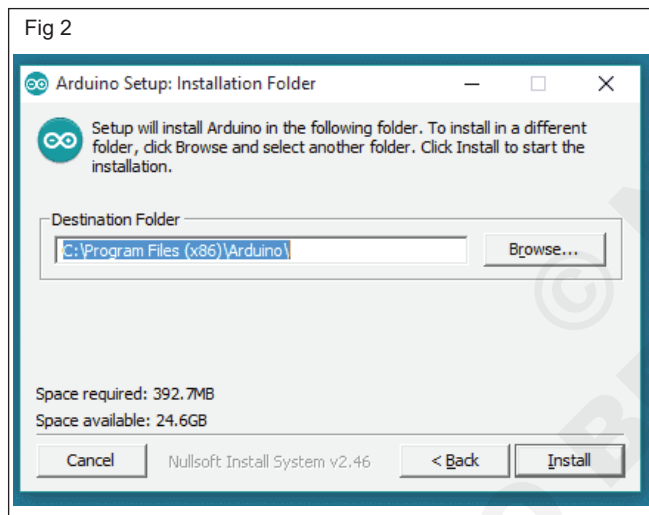

Installation in progress. (Fig 3)

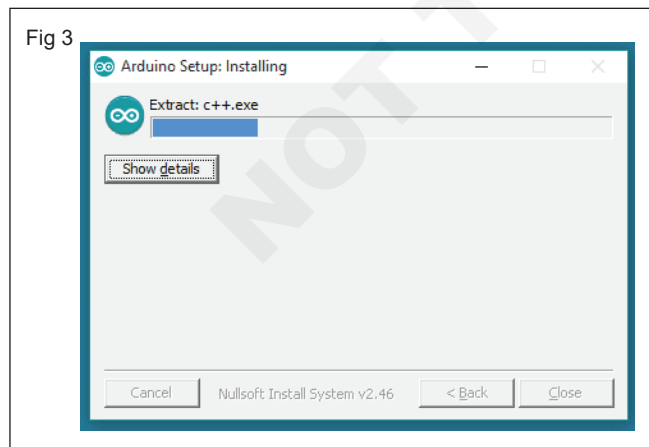

After installation Connecting Arduino Board to the Computer. (Fig 4)

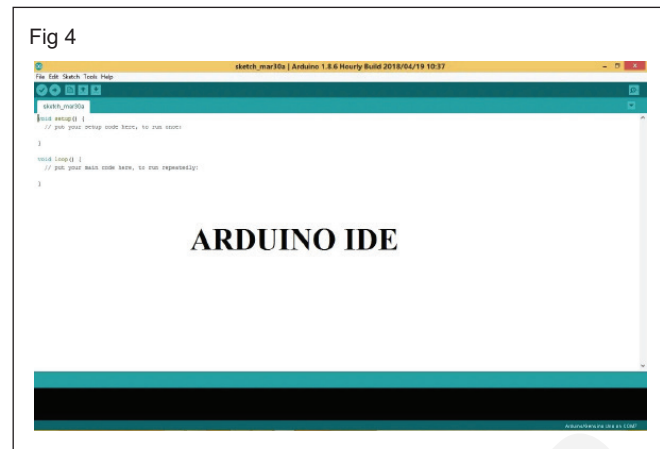

Connect the Arduino board to the computer, connect the appropriate cable to the Arduino board and connect the other end to the USB port of computer. The power LED will glow indicating the board is powered. The system will automatically install the driver for the board. (Fig 5)

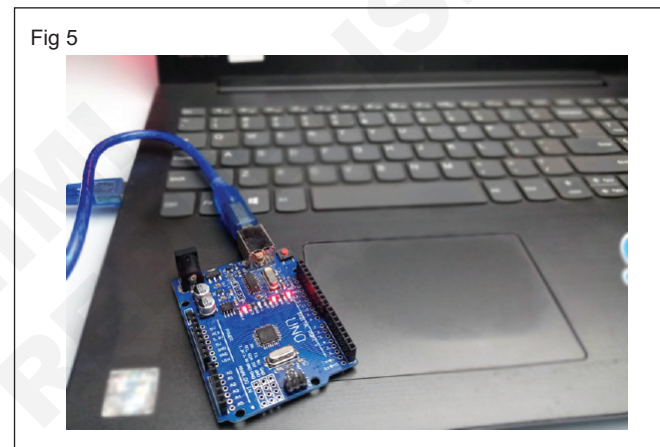

**Selecting the right Board on Arduino**

select the proper board. GO To "Tools" -> "Board" -> "Arduino AVR Boards" and select board from it. (Fig 6)

Fig 6

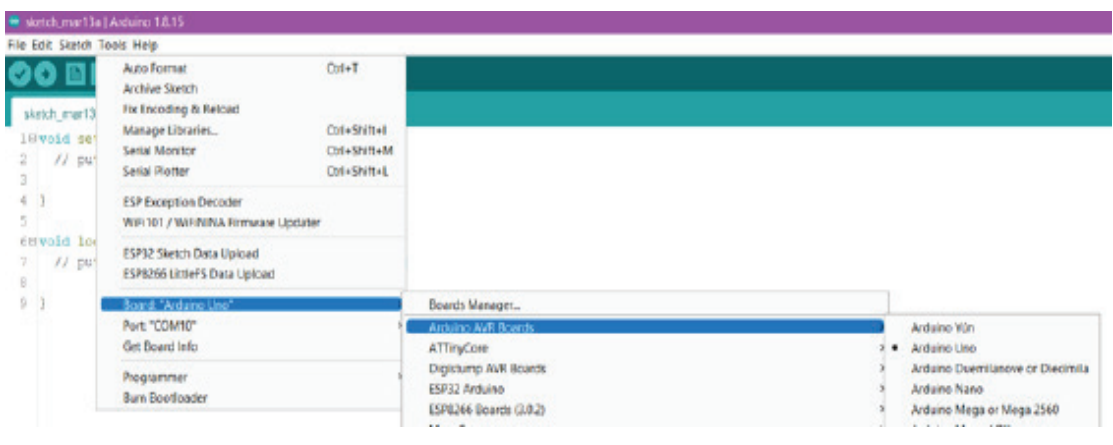

### Select the Arduino Serial Port

Select the Arduino Serial Port. click on “Tools” -> “Port”  
And select the correct COM port.

### Uploading Code on Arduino

upload the code to confirm that the Arduino is plugged in and the correct board and port are selected, either click the upload button in the quick action bar or click on Sketch -> Upload. Or keyboard shortcut Ctrl+U.

## Firmware and hardware integration with common errors and their solutions.

### Firmware integration

#### Common Error in the RPA (Drone)

Errors	Solution
Black Screen	Check USB is properly connected or not and Connect drone Again
Green Screen.	Check USB is properly connected or not and Connect drone Again
Aircraft Disconnect	Check signal and location of the field
No Image Transmission.	Check USB is properly connected or not
Command Time Out	Check transmitter and receiver connections
Signal Lost Aircraft Returning Home	Check GPS signals and use ATTI mode
Compass Error Exit P-GPS Mode	Check any interference
IMU Heading Error. Please Restart Aircraft	Calibrate IMU
Weak GPS Signal - Position Accuracy May Be Compromised. Fly With Caution	Change position and don't go near any metal coponents
Abnormal Compass Function or GPS Signal Detected.	Drone Switched To ATTI Mode
In Flight (No GPS)	Use ATTI mode/manual
Signal – Weak Image Transmission	Check video USB cable
Strong Wireless Interference	Move drone away from interference like tower etc.
Image Transmission Recovered	Check video USB cable
Error Code (code:203) Takeoff Failed	Check all the connections
Warning: Motor Overloaded. Aircraft Will Decelerate to Ensure Safety	Remove any extra payload from drone
Remote Controller Intermittent (Constant High Pitch Sound) While Charging	Check charging voltage and charger

## how to identify cause of coding errors.

Step 1: Make a Guess About Where the Bug Is Located.

Step 2: Set a Breakpoint and Inspect the Code.

Press **Go** to run through the code until the breakpoint is encountered.

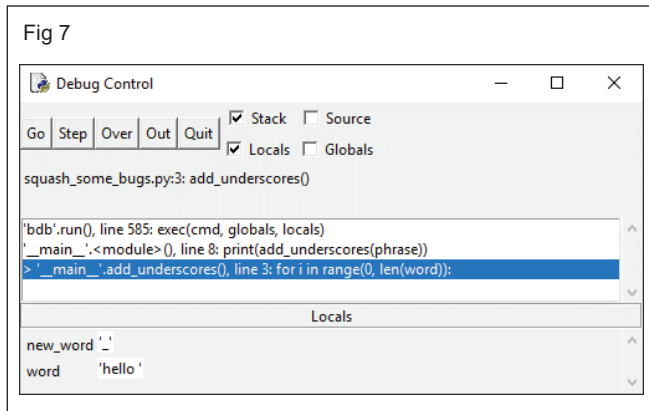

Click **Step** once to enter the *for* loop. The Debug window changes, and a new variable *i* with the value 0 is displayed in the Locals panel

*i* is the counter used in the *for* loop, and use it to keep track of which iteration of the *for* loop you're currently looking at.

Click **Step** one more time. look at the Locals panel, then see that the variable *new\_word* has taken on the value "h\_":

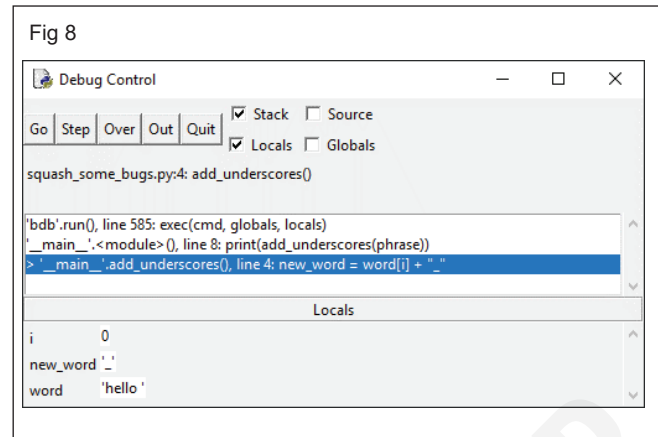

Step 3: Identify the Error and Attempt to Fix It.

Step 4: Repeat Steps 1 to 3 Until the Bug Is Gone.

## Drone Ground Station (Fig 9)

A drone ground station is a device used to communicate with drones, display real-time data about drone performance, upload new mission commands, and set parameters. It is also commonly used to monitor live video streams from drone cameras.



## The ground station system should have the following features

- 1 Flight monitoring function
- 2 Map navigation function:
- 3 Mission playback function
- 4 Antenna control function

## Introduction to preventive measures for drones.

Predictive maintenance is a valuable tool utilized by many industries, where data and robust predictive and

data analytics are leveraged to anticipate any issues or failures before they occur. As the name implies, these insights predict future behaviors and occurrences based on historical data and trends. Predictive maintenance is vital in both downtime prevention and overall cost savings. The objectives of predictive maintenance programs can be boiled down to one of two outcomes:

- Improving production efficiency.
- Improving maintenance efficiency.

## Drone service, Visual inspection and gimbal handling.

**Objectives:** At the end of this lesson you shall be able to

- explain the primary and secondary service
- state the gimbal handling and maintenance
- illustrate the GPS errors
- explain battery life maintenance
- define flight path
- state the throttle control
- define visual inspection
- illustrate the various checks in drone control.

### Fundamentals of primary and secondary services.

While the basic function of the maintenance department is to provide the engineering and support facilities for the uninterrupted, efficient and safe operation of the plant, we can group these activities into two general classifications as primary functions that are included in the justification of the department and secondary function

#### Primary functions

- 1 Engineering, scheduling, execution and control of the planned maintenance and repair of the equipment
- 2 Condition monitoring of the plant and equipment
- 3 Maintenance of the building and other facilities of the plant
- 4 Equipment inspection and lubrication
- 5 Maintaining and controlling of the workshops
- 6 Generation and distribution of utilities like power, steam and compressed air
- 7 New installations and/or alterations to the buildings and equipment
- 8 Engineering and supervision of the construction and installation projects within the scope of the organization
- 9 Technical consultation on mechanical problems with the production department
- 10 Performing all the above functions in a safe and efficient manner.

#### Secondary functions

- 1 Storekeeping, generally of maintenance items
- 2 Plant protection including fire protection
- 3 Industrial safety
- 4 Waste disposal and salvage
- 5 Insurance administration
- 6 Janitorial services
- 7 Property accounting
- 8 Pollution and noise control

- 9 Scrap yard control and maintenance
- 10 Vehicle maintenance and estate function
- 11 Any other function delegated by the management.

### Basics of Gimbal handling and its maintenance.

For ideal shooting effects, balancing the gimbal is necessary, and accurate balance will offer longer battery life.

#### Note:

- Before balancing the gimbal, please lock the gimbal at the balanced lock status, and the lens cover should be removed from the camera and the memory card needs to be inserted to the camera to complete all the connections to ensure that the camera is ready for shooting.

Fig 1

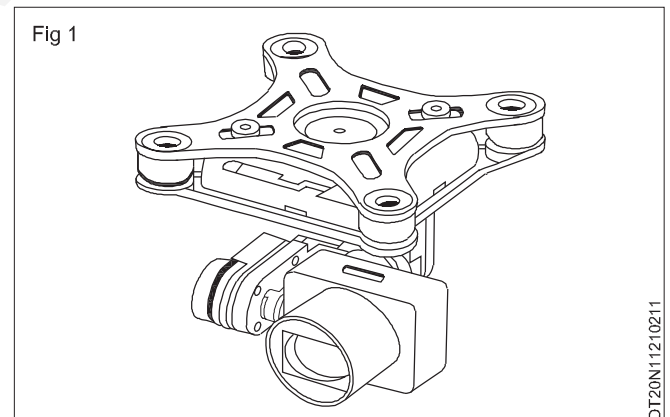

- The camera is ready for shooting and has mounted on the gimbal.
- During balancing the gimbal, make sure the camera and gimbal are all powered off.
- If it is needed to add accessories after the balance is completed, gimbal needs to be re-balanced again

#### Balance tilt axis

- Turn the camera lens forward.
- Unlock the safety lock.
- Move the camera to balance.



- Lock the safety lock after camera can keep horizontally forward.
- Turn the camera lens forward.
- Unlock the safety lock.
- Move the camera to balance.
- Lock the safety lock after camera can keep horizontally forward.

#### Balance roll axis

- Turn the camera lens forward.
- Unlock the safety lock.
- Loosen the lock screw.
- Move the camera to balance.
- Tighten the lock screw after balanced.

#### Balance pan axis

- Hold the handle aslant to 15°~20°.
- Loosen the lock screw (red).
- Move the camera to balance.
- Tighten the lock screw after balanced.

#### Fundamentals of handling errors rise from GPS.

##### Not enough satellites

GPS devices ideally need to receive signals from at least 7 or 8 satellites to calculate location to within about 10 meters. With less than 4 satellites, many GPS receivers struggle to produce accurate location estimates, and will report “GPS signal lost” at points during the route.

##### Poor Hardware

Old GPS will struggle to receive satellite signals.

##### Low Battery on GPS devices

Low battery can affect the proper functioning of the GPS.

##### Multipath signals

When signals from the GPS satellites bounce off buildings, the GPS receiver can be confused by the extra time the signal took to reach it. In these cases, may observe sudden errors in position. There is not much that can be done in these circumstances to reduce the effects of multipath errors. GPS is simply less accurate in these situations.

#### GPS Drift

The GPS track deviates from the road.

#### Lost GPS signal

If a signal is lost and sometime later re-acquired the pre- and post-signal-loss points will be treated just like any other two points and connect them with a straight line.

#### Radio interference or jamming

a device’s GPS hardware is working fine, but the software being used is faulty.

#### Improve your GPS Accuracy

GPS satellites broadcast their signals in space with a certain amount of accuracy, but receive at ground level depends on factors including:

- satellite geometry
- receiver design features/quality
- signal blockage
- atmospheric conditions

#### Flight Path Monitoring

Flight path monitoring means the observation and interpretation of the flight path data, drone-configuration status, automation modes and on-board systems appropriate to the phase of flight. It involves a cognitive comparison of real-time data against the expected values, modes and procedures.

This definition covers anytime the drone is in motion, including during taxi. It also includes continuous awareness of both the trajectory and energy state of the drone.

#### Flight Phases and Modes (Fig 2)

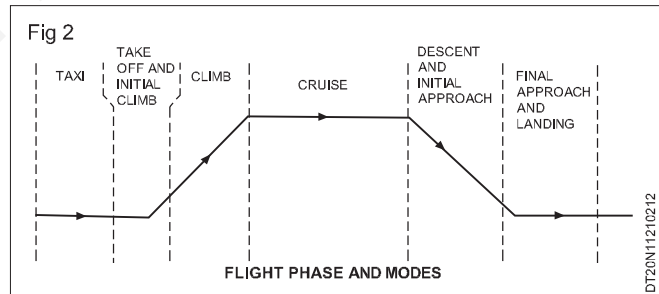

## Studying throttle control by moving in either direction

The left stick moves up and down makes the drone changes its altitude

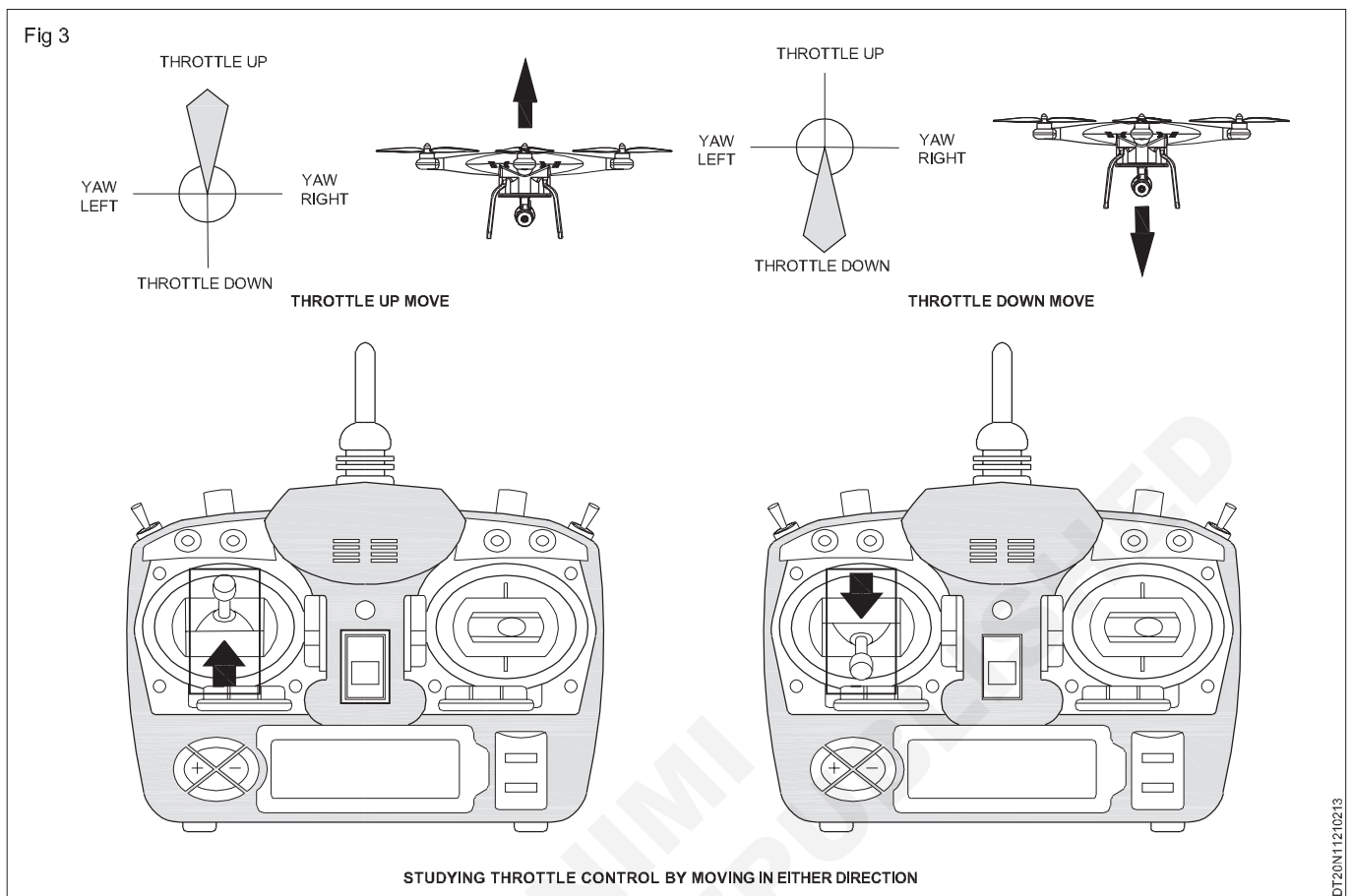

### Concept of Visual Inspection and Why Is It Important

#### Visual Inspection

- Visual Inspection, or Visual Testing (VT), is the oldest and most basic method of inspection. It is the process of looking over a piece of equipment using the naked eye to looking for flaws. It requires no equipment except the naked eye of a trained inspector.
- Visual inspection can be used for internal and external surface inspection of a variety of equipment types, including storage tanks, pressure vessels, piping and other equipment.

**Understand the various checks to be carried out to ensure the alignment of control surfaces.**

#### Equipment check

Inspect all component for visual damage. If the part is damaged, it will cause the drone to behave incorrectly.

Replace or repair damaged components.

#### System reset

Step 1: Hold down the power button on the drone for few seconds until you hear three beeps. Then do the same on the controller.

Step 2: The next thing is to power off both the controller and the drone.

#### Calibration

Follow the calibration procedure for your flight controller to ensure your compass and IMU are properly calibrated before flight.

### Motor Troubleshooting

drone motor may not be spinning due to visible obstructions, a bent motor shaft, worn out mounts, or other broken components inside the motor housing.

#### Gimbal rotation

By inspecting your take-off site, you can check if the gimbal motor overload is caused by obstructions stopping the gimbal from rotating.

#### Battery Maintenance

Battery cell voltage difference is less than 0.1V after the battery is fully charged and left stationary for 6 hours. This can be checked in the drone's flight app. Battery should not swollen, leaky, or damaged.

#### RF Signal

The basic setup to intercept drone transmission consists of an antenna, RF receiver, and a processing unit. Recorded data are usually post-processed and further analyzed in software, using either a frequency-domain or time-domain approach.

#### Hardware

Inspect all hardware components. If the part is damaged, it will cause the drone to behave incorrectly.

Replace or repair damaged Hardware

#### Firmware Upgrade firmware via App.

- 1 Tap upgrade ICON on App.
- 2 Select upgrade type.
- 3 Follow the prompts to upgrade the firmware.